

QD72P3C3 Type Positioning Module
with Built-in Counter Function

User's Manual

mitsubishi

Q series
Q series

Mitsubishi
Programmable Controller

MELSEC-Q

QD72P3C3
GX Configurator-PT
(SW1D5C-QPTU-E)

● SAFETY PRECAUTIONS ●

(Read these precautions before use.)

Before using this product, please read this manual and the relevant manuals introduced in this manual carefully and pay full attention to safety to handle the product correctly.

The precautions given in this manual are concerned with this product. For the safety precautions of the programmable controller system, please read the User's Manual for the CPU module.

In this manual, the safety precautions are classified into two levels: "⚠ WARNING" and "⚠ CAUTION".



Indicates that incorrect handling may cause hazardous conditions, resulting in death or severe injury.



Indicates that incorrect handling may cause hazardous conditions, resulting in minor or moderate injury or property damage.

Under some circumstances, failure to observe the precautions given under "⚠ CAUTION" may lead to serious consequences.

Observe the precautions of both levels because they are important for personal and system safety.

Please save this manual to make it accessible when required and always forward it to the end user.

[DESIGN PRECAUTIONS]

⚠ WARNING

- Provide a safety circuit outside the programmable controller so that the entire system will operate safely even when an external power error or programmable controller failure occurs.
Failure to do so may cause an accident due to incorrect output or malfunction.
 - (1) Outside the programmable controller, create an emergency stop circuit or interlock circuit to prevent mechanical damage due to excess of position control upper limit/lower limit.
 - (2) The machine OPR control is controlled by the OPR direction and OPR speed data and deceleration starts when the near-point dog turns ON. Thus, if the OPR direction is incorrectly set, deceleration may not start and the motor continues rotating. Create an interlock circuit outside the programmable controller to prevent mechanical damage.
 - (3) If the positioning module detects an error, it directs the motor to decelerate and stop.
Make sure that the OPR data and positioning data are within the parameter setting values.

⚠ CAUTION

- Do not install the control lines, communication cables, pulse input wiring, and pulse output wiring together with the main circuit or power lines, and also do not bring them close to each other.
Keep a distance of 100mm (3.94inch) or more between them.
Failure to do so may cause a malfunction due to noise.

[INSTALLATION PRECAUTIONS]

CAUTION

- Use the programmable controller in the environment conditions given in the general specifications of the User's Manual for the CPU module.
Failure to do so may cause an electric shock, fire, malfunction, or damage to or deterioration of the product.
- While pressing the installation lever located at the bottom of the module, fully insert the module fixing projection into the fixing hole in the base unit and press the module using the hole as a fulcrum.
Incorrect module mounting may cause a malfunction, failure, or drop of the module.
In an environment of frequent vibrations, secure the module with screws.
Tighten the screw within the specified torque range. Undertightening can cause drop of the screw, short circuit or malfunction. Overtightening can damage the screw and/or module, resulting in drop, short circuit, or malfunction.
- Be sure to shut off all phases of the external power supply used by the system before mounting or removing the module.
Failure to do so may cause damage to the product.
- Do not directly touch any conductive part or electronic part of the module.
Doing so may cause a malfunction or failure of the module.

[WIRING PRECAUTIONS]

WARNING

- Shut off the external power supply for the system in all phases before wiring.
Failure to do so may result in electric shock or damage to the product.

[WIRING PRECAUTIONS]

CAUTION

- Check the terminal layout before wiring to the module, and connect the cables correctly.
- Solder connectors for external devices correctly.
Incomplete soldering may result in malfunction.
- Prevent foreign matter such as dust or wire chips from entering the module.
Such foreign matter can cause a fire, failure, or malfunction.
- A protective film is attached to the top of the module to prevent foreign matter, such as wire chips, from entering the module during wiring.
Do not remove the film during wiring.
Remove it for heat dissipation before system operation.
- Securely connect connectors for external devices to the module connector and fully tighten the two screws.
- When disconnecting the external wiring cable connected to the module, do not pull it by holding the cable part. Disconnect the cable with connector with holding the connector plugged into the module.
Pulling the cable part with the cable still connected to the module may cause a malfunction or damage to the module and/or cable.
- Do not install cables for connecting external I/O signals of the QD72P3C3 and drive unit together with the main circuit cables, power cables, and/or the load cables for any other than programmable controllers or not bring them close to each other.
Keep a distance of 100mm (3.94 inches) or more between them.
Failure to do so may cause a malfunction due to noise, surge or induction.

[STARTUP/MAINTENANCE PRECAUTIONS]

WARNING

- Be sure to shut off all phases of the external power supply used by the system before cleaning or retightening module fixing screw.
Failure to do so may cause an electric shock.

CAUTION

- Do not or remodel each of the modules.
Doing so may cause failure, malfunctions, personal injuries and/or a fire.
- Be sure to shut off all phases of the external power supply used by the system before mounting or removing the module.
Not doing so may result in a failure or malfunction of the module.
- Do not install/remove the module to/from the base unit more than 50 times after the first use of the product. (IEC 61131-2 compliant)
Failure to do so may cause malfunction.
- Before starting test operation, set the parameter speed limit value slow, and prepare so that operation can be stopped immediately in case of hazardous situation.
- Before handling the module, touch a grounded metal object to discharge the static electricity from the human body.
Not doing so may result in a failure or malfunction of the module.

[DISPOSAL PRECAUTIONS]

CAUTION

- When disposing of this product, treat it as industrial waste.

● CONDITIONS OF USE FOR THE PRODUCT ●

- (1) Mitsubishi programmable controller ("the PRODUCT") shall be used in conditions;
 - i) where any problem, fault or failure occurring in the PRODUCT, if any, shall not lead to any major or serious accident; and
 - ii) where the backup and fail-safe function are systematically or automatically provided outside of the PRODUCT for the case of any problem, fault or failure occurring in the PRODUCT.
- (2) The PRODUCT has been designed and manufactured for the purpose of being used in general industries.

MITSUBISHI SHALL HAVE NO RESPONSIBILITY OR LIABILITY (INCLUDING, BUT NOT LIMITED TO ANY AND ALL RESPONSIBILITY OR LIABILITY BASED ON CONTRACT, WARRANTY, TORT, PRODUCT LIABILITY) FOR ANY INJURY OR DEATH TO PERSONS OR LOSS OR DAMAGE TO PROPERTY CAUSED BY the PRODUCT THAT ARE OPERATED OR USED IN APPLICATION NOT INTENDED OR EXCLUDED BY INSTRUCTIONS, PRECAUTIONS, OR WARNING CONTAINED IN MITSUBISHI'S USER, INSTRUCTION AND/OR SAFETY MANUALS, TECHNICAL BULLETINS AND GUIDELINES FOR the PRODUCT.

("Prohibited Application")

Prohibited Applications include, but not limited to, the use of the PRODUCT in;

- Nuclear Power Plants and any other power plants operated by Power companies, and/or any other cases in which the public could be affected if any problem or fault occurs in the PRODUCT.
- Railway companies or Public service purposes, and/or any other cases in which establishment of a special quality assurance system is required by the Purchaser or End User.
- Aircraft or Aerospace, Medical applications, Train equipment, transport equipment such as Elevator and Escalator, Incineration and Fuel devices, Vehicles, Manned transportation, Equipment for Recreation and Amusement, and Safety devices, handling of Nuclear or Hazardous Materials or Chemicals, Mining and Drilling, and/or other applications where there is a significant risk of injury to the public or property.

Notwithstanding the above, restrictions Mitsubishi may in its sole discretion, authorize use of the PRODUCT in one or more of the Prohibited Applications, provided that the usage of the PRODUCT is limited only for the specific applications agreed to by Mitsubishi and provided further that no special quality assurance or fail-safe, redundant or other safety features which exceed the general specifications of the PRODUCTS are required. For details, please contact the Mitsubishi representative in your region.

REVISIONS

* The manual number is given on the bottom left of the back cover.

Print date	*Manual number	Revision
Jun., 2007	SH(NA)-080683ENG-A	First edition
Jan., 2008	SH(NA)-080683ENG-B	Correction About the Generic Terms and Abbreviations, Section 2.3 to 2.6, Section 6.2.1, Section 6.2.2 Appendix 1
May, 2008	SH(NA)-080683ENG-C	Correction SAFETY PRECAUTIONS, Compliance with the EMC and Low Voltage Directives, Section 2.3, 2.6, 3.1, 5.4.1, 6.2.1, 6.3.1, 6.3.3, 14.1 to 14.5, 15.2.1 Added Section 12.8
Sep., 2009	SH(NA)-080683ENG-D	Correction SAFETY PRECAUTIONS, Section 1.1, 2.3, 2.4, 2.6, 3.1, 5.1, 5.3, 6.2.1, Appendix 1, 5, 8
May, 2010	SH(NA)-080683ENG-E	Correction SAFETY PRECAUTIONS, GENERIC TERMS AND ABBREVIATIONS, Section 2.3, 2.6, 4.1.1, 5.1, 5.3, 5.4.1, 6.2.1, 7.1, 8.2.3, 11.5, 12.5, 15.2.1, 15.3 Added CONDITIONS OF USE FOR THE PRODUCT

Japanese Manual Version SH-080682-E

This manual confers no industrial property rights or any rights of any other kind, nor does it confer any licenses. Mitsubishi Electric Corporation cannot be held responsible for any problems involving industrial property rights which may occur as a result of using the contents noted in this manual.

INTRODUCTION

Thank you for purchasing the Mitsubishi programmable controller MELSEC-Q series.
Before using the product, please read this manual carefully to develop full familiarity with the functions and performance of the Q series programmable controller to ensure correct use.

CONTENTS

SAFETY PRECAUTIONS	A - 1
CONDITIONS OF USE FOR THE PRODUCT	A - 5
REVISIONS	A - 6
INTRODUCTION	A - 7
CONTENTS	A - 7
HOW TO READ THIS MANUAL	A - 12
Compliance with the EMC and Low Voltage Directives	A - 12
GENERIC TERMS AND ABBREVIATIONS	A - 13
PACKING LIST	A - 13

PART 1 PRODUCT SPECIFICATIONS AND HANDLING

CHAPTER1 PRODUCT OUTLINE 1 - 1 to 1 - 13

1.1 Features of QD72P3C3	1 - 1
1.2 Outline of Positioning Control and Count Operation	1 - 3
1.2.1 Mechanism of positioning control	1 - 3
1.2.2 Design outline of positioning control system	1 - 5
1.2.3 Design outline of counter function	1 - 8
1.2.4 Communicating signals between QD72P3C3 and each module	1 - 9
1.3 Basic Operation of Positioning Control	1 - 12
1.3.1 Outline of control start	1 - 12
1.3.2 Outline of control stop	1 - 13

CHAPTER2 SYSTEM CONFIGURATION 2 - 1 to 2 - 11

2.1 General Image of System	2 - 1
2.2 Component List	2 - 2
2.3 Applicable Systems	2 - 3
2.4 Using QD72P3C3 with Redundant CPUs	2 - 7
2.5 About Use of the QD72P3C3 with the MELSECNET/H Remote I/O Station	2 - 8
2.6 Checking Function Version, Serial Number and Software Version	2 - 9

CHAPTER3 SPECIFICATIONS AND FUNCTIONS 3 - 1 to 3 - 19

3.1 Performance Specifications	3 - 1
3.2 Function List	3 - 2

3.3	Specifications of I/O Signals with Programmable Controller CPU.....	3 - 4
3.3.1	List of I/O signals with programmable controller CPU.....	3 - 4
3.3.2	Details of input signal (QD72P3C3 programmable controller CPU).....	3 - 6
3.3.3	Details of output signals (programmable controller CPU QD72P3C3).....	3 - 8
3.4	List of Buffer Memory Addresses	3 - 10
3.5	Specifications of I/O Interfaces with External Device	3 - 12
3.5.1	Electrical specifications of I/O signals	3 - 12
3.5.2	Signal layout for external device connector	3 - 16
3.5.3	List of I/O signal details	3 - 17
3.5.4	Internal circuit of I/O interface.....	3 - 18

CHAPTER4 DATA USED FOR POSITIONING CONTROL 4 - 1 to 4 - 31

4.1	Data Types	4 - 1
4.1.1	Parameters and data required for control	4 - 1
4.1.2	Parameter setting items.....	4 - 3
4.1.3	JOG data setting items.....	4 - 5
4.1.4	Positioning data setting items.....	4 - 5
4.1.5	Types and functions of monitor data	4 - 6
4.1.6	Types and functions of control data	4 - 6
4.2	Parameter List	4 - 7
4.3	JOG Data List.....	4 - 21
4.4	Positioning Data List.....	4 - 23
4.5	Monitor Data List	4 - 28
4.6	Control Data List	4 - 30
4.6.1	Axis control data.....	4 - 30

CHAPTER5 PROCEDURES AND SETTINGS BEFORE OPERATION 5 - 1 to 5 - 21

5.1	Handling Precautions	5 - 1
5.2	Procedures Before Operation	5 - 3
5.3	Part Names	5 - 4
5.4	Wiring	5 - 7
5.4.1	Wiring precautions	5 - 7
5.5	Wiring Check.....	5 - 12
5.5.1	Check items at wiring completion	5 - 12
5.6	Intelligent Function Module Switch Setting.....	5 - 14
5.7	Simple Reciprocating Operation	5 - 18

CHAPTER6 UTILITY PACKAGE (GX Configurator-PT) 6 - 1 to 6 - 22

6.1	Utility Package Functions	6 - 1
6.2	Installing and Uninstalling the Utility Package.....	6 - 2
6.2.1	Handling precautions	6 - 2
6.2.2	Operating environment.....	6 - 4
6.3	Utility Package Operation	6 - 6

6.3.1	Common utility package operations	6 - 6
6.3.2	Operation overview	6 - 8
6.3.3	Starting the Intelligent function module utility	6 - 10
6.4	Initial Setting	6 - 12
6.5	Auto Refresh Setting	6 - 15
6.6	Monitor/Test.....	6 - 17
6.6.1	Monitor/Test screen.....	6 - 17
6.6.2	ACC/DEC time calculation function screen	6 - 21

CHAPTER7 SEQUENCE PROGRAM USED FOR POSITIONING CONTROL

7 - 1 to 7 - 31

7.1	Precautions for Creating Program	7 - 1
7.2	List of Devices Used	7 - 4
7.3	Creating a Program.....	7 - 9
7.3.1	General configuration of program	7 - 9
7.3.2	Positioning control operation program	7 - 10
7.4	Positioning Control Program Examples	7 - 13
7.5	Program Details	7 - 23
7.5.1	Initialization program	7 - 23
7.5.2	Start method setting program	7 - 24
7.5.3	Start program	7 - 25
7.5.4	Auxiliary program.....	7 - 30
7.6	Program Example when the Coincidence Detection Interrupt Function is Used	7 - 31

PART 2 CONTROL DETAILS AND SETTING

CHAPTER8 OPR CONTROL

8 - 1 to 8 - 12

8.1	Outline of OPR Control	8 - 1
8.1.1	Two types of OPR control	8 - 1
8.2	Machine OPR Control.....	8 - 2
8.2.1	Outline of the machine OPR operation.....	8 - 2
8.2.2	OPR method for machine OPR control	8 - 4
8.2.3	OPR method (1): Near-point dog method	8 - 5
8.2.4	OPR method (2): Stopper 3	8 - 8
8.3	Fast OPR Control	8 - 10
8.3.1	Outline of the fast OPR control operation	8 - 10
8.4	Count Value Selection Function at OPR	8 - 12

CHAPTER9 POSITIONING CONTROL

9 - 1 to 9 - 15

9.1	Outline of Positioning Control.....	9 - 1
9.1.1	Data required for positioning control.....	9 - 1
9.1.2	Positioning control operation patterns.....	9 - 2
9.1.3	Specifying the positioning address	9 - 4
9.1.4	Checking the current value.....	9 - 5

9.2	Positioning Data Setting	9 - 7
9.2.1	Relation between each control and positioning data	9 - 7
9.2.2	1-axis linear control	9 - 8
9.2.3	Speed control	9 - 10
9.2.4	Current value change	9 - 13
9.3	Multiple axes concurrent start control	9 - 15

CHAPTER10 JOG OPERATION **10 - 1 to 10 - 7**

10.1	Outline of JOG Operation	10 - 1
10.2	JOG Operation Execution Procedure	10 - 4
10.3	JOG Operation Example	10 - 5

CHAPTER11 AUXILIARY FUNCTION **11 - 1 to 11 - 16**

11.1	Outline of the Auxiliary Function	11 - 1
11.2	Speed Limit Function	11 - 2
11.3	Speed Change Function	11 - 3
11.4	Software Stroke Limit Function	11 - 6
11.5	Hardware Stroke Limit Function	11 - 9
11.6	ACC/DEC Process Function	11 - 11
11.6.1	Calculating the actual ACC/DEC time	11 - 13

CHAPTER12 COUNTER FUNCTION **12 - 1 to 12 - 15**

12.1	Outline of Counter Function	12 - 1
12.1.1	Types of pulse input method	12 - 1
12.1.2	Reading count values	12 - 2
12.1.3	Selecting counter format	12 - 2
12.2	Linear Counter Function	12 - 3
12.3	Ring Counter Function	12 - 4
12.4	Count Enable Function	12 - 6
12.5	Coincidence Detection Function	12 - 7
12.6	Preset Function	12 - 11
12.7	Current Feed Value, Count Value Simultaneous Change Function	12 - 12
12.8	Response Delay Time	12 - 15

CHAPTER13 COMMON FUNCTION **13 - 1 to 13 - 4**

13.1	Outline of Common Function	13 - 1
13.2	External I/O Signal Logic Switching Function	13 - 2
13.3	External I/O Signal Monitor Function	13 - 3

CHAPTER14 DEDICATED INSTRUCTIONS	14 - 1 to 14 - 14
14.1 Dedicated Instruction List and Applicable Devices	14 - 1
14.2 Interlock for Dedicated Instruction Execution.....	14 - 2
14.3 ZP.PSTRT1, ZP.PSTRT2, ZP.PSTRT3	14 - 3
14.4 ZP.DSTRT1, ZP.DSTRT2, ZP.DSTRT3.....	14 - 8
14.5 ZP.SPCHG1, ZP.SPCHG2, ZP.SPCHG3.....	14 - 12

CHAPTER15 TROUBLESHOOTING	15 - 1 to 15 - 22
15.1 Troubleshooting Flow	15 - 1
15.1.1 When the RUN LED turns OFF.....	15 - 2
15.1.2 When the ERR.LED turns ON	15 - 2
15.1.3 When the AX LED flashes after the ERR.LED flashes.....	15 - 2
15.1.4 When the axis/CH warning occurrence signal (X4 to X6) turns ON	15 - 2
15.1.5 When the count operation is not executed, or not executed normally	15 - 3
15.1.6 When the coincidence detection interrupt does not occur.....	15 - 4
15.2 Error and Warning Descriptions.....	15 - 5
15.2.1 Error code list	15 - 7
15.2.2 List of warnings	15 - 19
15.3 Checking Errors with the LED Display Function	15 - 21
15.4 Checking Error Description Using System Monitor of GX Developer.....	15 - 22

APPENDICES	App - 1 to App - 21
Appendix 1 External Dimensions	App - 1
Appendix 2 Operation Timing and Processing Time in Each Control.....	App - 2
Appendix 3 Connection Examples with Servo Amplifiers Manufactured by Mitsubishi Electric Corporation	App - 7
Appendix 4 Connection Examples with Stepping Motors Manufactured by ORIENTAL MOTOR CO., LTD.	App - 11
Appendix 5 Connection Examples with Servo Amplifiers Manufactured by Panasonic Corporation	App - 13
Appendix 6 Connection Examples with Servo Amplifiers Manufactured by YASKAWA ELECTRIC CORPORATION	App - 15
Appendix 7 Connection Examples with Servo Amplifiers Manufactured by SANYO DENKI CO., LTD.	App - 16
Appendix 8 Comparison with QD70P type positioning module	App - 17
Appendix 9 List of Buffer Memory Addresses	App - 20

INDEX	Index - 1 to Index - 2
--------------	-------------------------------

HOW TO READ THIS MANUAL

(1) The symbols used in this manual are shown below.

Pr.* Indicates parameter item.

JOG.* Indicates JOG data item.

Da.* Indicates positioning data item.

Md.* Indicates monitor data item.

Cd.* Indicates control data item.

(Serial No. is displayed at the *.)

(2) Numeric values used in this manual

The buffer memory addresses, error codes and warning codes are represented in decimal.

The X/Y devices are represented in hexadecimal.

The setting data and monitor data are represented in either decimal or hexadecimal.

The data whose name is ended by "H" are represented in hexadecimal.

(Example) 10.....Decimal, 10_H.....Hexadecimal

Compliance with the EMC and Low Voltage Directives

(1) For programmable controller system

To configure a system meeting the requirements of the EMC and Low Voltage Directives when incorporating the Mitsubishi programmable controller (EMC and Low Voltage Directives compliant) into other machinery or equipment, refer to Chapter 9 "EMC AND LOW VOLTAGE DIRECTIVES" of the QCPU User's Manual (Hardware Design, Maintenance and Inspection).

The CE mark, indicating compliance with the EMC and Low Voltage Directives, is printed on the rating plate of the programmable controller.

(2) For the product

To make this product conform to the EMC and Low Voltage Directives, please refer to "Section 5.4.1 Wiring precautions".

GENERIC TERMS AND ABBREVIATIONS

Unless otherwise specified, this manual uses the following generic terms and abbreviations.

Generic term and abbreviation	Description
Programmable controller CPU	Generic term for the programmable controller CPU to which the QD72P3C3 can be mounted.
QD72P3C3	Abbreviation for the QD72P3C3 type positioning module with built-in counter function
Peripheral	Generic term for IBM-PC/AT-compatible personal computer in which "GX Configurator-PT" and "GX Developer" below have been installed.
GX Configurator-PT	Abbreviation for utility package GX Configurator-PT (SW1D5C-QPTU-E) for the QD72P3C3 type positioning module
GX Developer	Product name of the software package for the MELSEC programmable controllers
GX Works2	
Personal computer	Generic term for IBM-PC/AT-compatible personal computer
Workpiece	Generic term for mobile object and controlled object such as workpiece and industrial tool
Windows Vista®	Generic term for the following: Microsoft® Windows Vista® Home Basic Operating System, Microsoft® Windows Vista® Home Premium Operating System, Microsoft® Windows Vista® Business Operating System, Microsoft® Windows Vista® Ultimate Operating System, Microsoft® Windows Vista® Enterprise Operating System
Windows® XP	Generic term for the following: Microsoft® Windows® XP Professional Operating System, Microsoft® Windows® XP Home Edition Operating System

PACKING LIST

The following are included in the package.

Model	Product name	Quantity
QD72P3C3	QD72P3C3 type positioning module with built-in counter function	1
SW1D5C-QPTU-E	GX Configurator-PT Version 1 (single license product) (CD-ROM)	1
SW1D5C-QPTU-AE	GX Configurator-PT Version 1 (volume license product) (CD-ROM)	1

PART 1 PRODUCT SPECIFICATIONS AND HANDLING

PART 1 consists for the following purposes (1) to (4).

- (1) To understand the outline of positioning control, and the QD72P3C3 specifications and functions
- (2) To perform actual work such as installation and wiring
- (3) To set parameters and data required for positioning control
- (4) To create a sequence program required for positioning control

For details of each control, refer to "PART 2".

CHAPTER1	PRODUCT OUTLINE	1 - 1 to 1 -
CHAPTER2	SYSTEM CONFIGURATION	2 - 1 to 2 -
CHAPTER3	SPECIFICATIONS AND FUNCTIONS	3 - 1 to 3 -
CHAPTER4	DATA USED FOR POSITIONING CONTROL	4 - 1 to 4 -
CHAPTER5	PROCEDURES AND SETTINGS BEFORE OPERATION	5 - 1 to 5 -
CHAPTER6	UTILITY PACKAGE (GX Configurator-PT)	6 - 1 to 6 -
CHAPTER7	SEQUENCE PROGRAM USED FOR POSITIONING CONTROL	7 - 1 to 7 -
CHAPTER8	OPR CONTROL	8 - 1 to 8 -
CHAPTER9	POSITIONING CONTROL	9 - 1 to 9 -
CHAPTER10	JOG OPERATION	10 - 1 to 10 -
CHAPTER11	AUXILIARY FUNCTION	11 - 1 to 11 -
CHAPTER12	COUNTER FUNCTION	12 - 1 to 12 -
CHAPTER13	COMMON FUNCTION	13 - 1 to 13 -
CHAPTER14	DEDICATED INSTRUCTIONS	14 - 1 to 14 -
CHAPTER15	TROUBLESHOOTING	15 - 1 to 15 -

CHAPTER1 PRODUCT OUTLINE

This User's Manual describes the specifications, handling, and programming methods for the type QD72P3C3 positioning module with built-in counter function used together with the MELSEC-Q series CPU module.

When applying any of the program examples introduced in this manual to the actual system, verify the applicability and confirm that no problem occurs in the system control.

1.1 Features of QD72P3C3

The following describes the features of the QD72P3C3.

(1) Space saving

The QD72P3C3 provides 3-axes of positioning control and 3-channels of counter function per slot.

(2) Positioning control

- (a) The QD72P3C3 is an open-collector output type module, which can output pulses at a maximum rate of 100kpps.
- (b) The pulse output mode is selectable.
The pulse output mode can be selected from PULSE/SIGN and CW/CCW.
- (c) Easy positioning control with only a few parameter settings is possible.
With only a few parameter settings, such as "Command speed", "ACC/DEC time" and "Positioning address/movement amount", positioning control can be performed.
- (d) 3-axes concurrent start is possible.
- (e) Speed change during positioning control is possible by the target speed change function.

(3) Counter function

- (a) With this function, a maximum counting speed of 100kpps is possible.
- (b) A counting range is from -1073741824 to 1073741823.
- (c) The pulse input mode is selectable.
The pulse input mode can be selected from 1 multiple of 2 phases, 2 multiples of 2 phases, 4 multiples of 2 phases, and CW/CCW.
- (d) The coincidence detection function is provided.
The coincidence detection point preset at an arbitrary channel is compared to the current counter value and the result can be checked.
When the current counter value coincides with the preset detection point, an interrupt program can be started using an interrupt pointer.

(4) Easy setting using GX Configurator-PT

With optional GX Configurator-PT, the QD72P3C3 settings can be configured on screen.

This reduces a load on sequence programs and makes checking the settings and operating status of the module easier.

1.2 Outline of Positioning Control and Count Operation

1.2.1 Mechanism of positioning control

Positioning control using the QD72P3C3 is performed using "pulse signals". (The QD72P3C3 is a module that outputs pulses.)

In a positioning control system using the QD72P3C3, a variety of software and external devices are used to play their roles as shown below.

The QD72P3C3 realizes complex positioning control by importing and controlling various signals, parameters, and data with the programmable controller CPU.

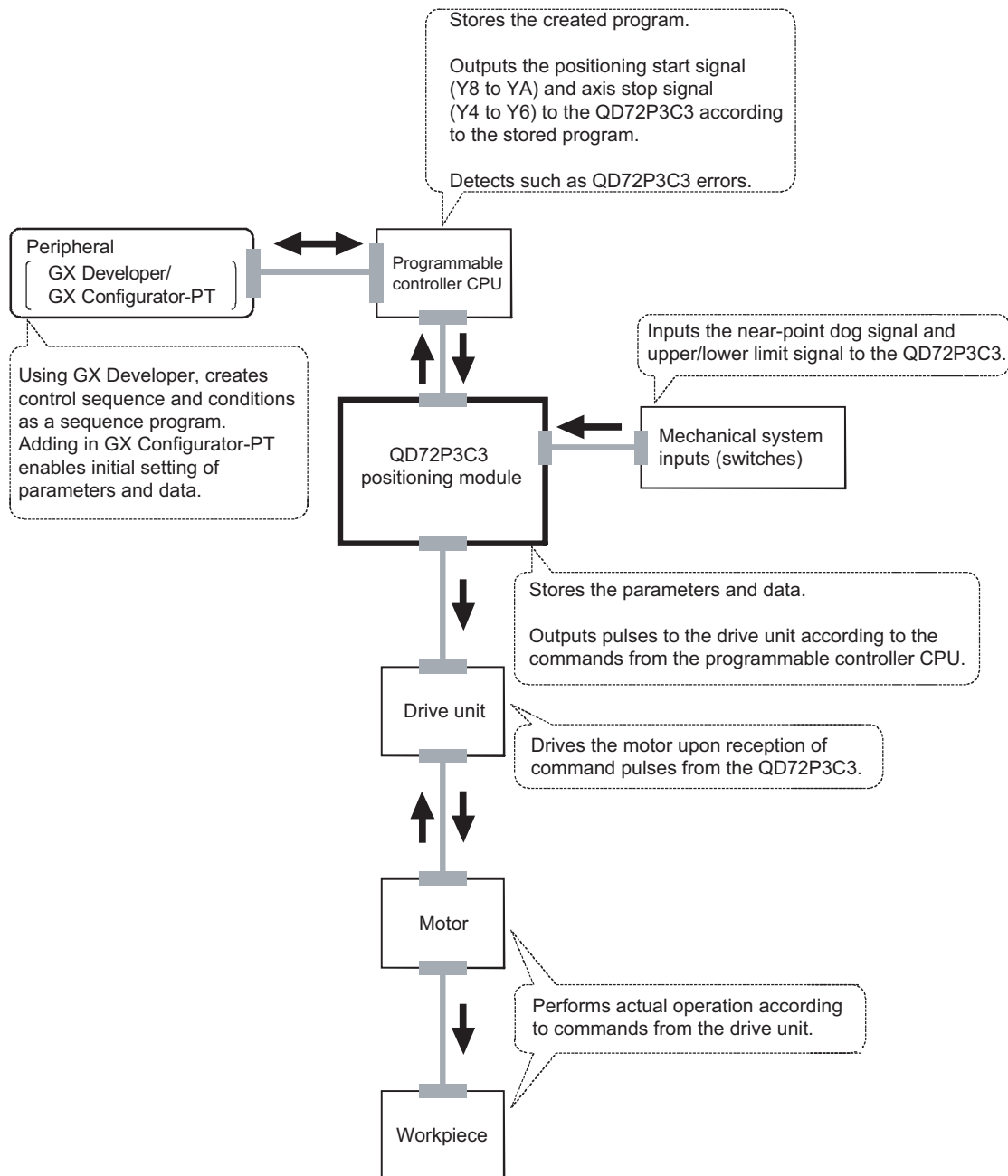

1 PRODUCT OUTLINE

2 SYSTEM CONFIGURATION

3 SPECIFICATIONS AND FUNCTIONS

4 DATA USED FOR POSITIONING CONTROL

5 PROCEDURES AND SETTINGS BEFORE OPERATION

6 UTILITY PACKAGE (GX Configurator-PT)

7 SEQUENCE PROGRAM USED FOR POSITIONING

8 OPR CONTROL

The following describes the operation principle of "position control" and "speed control".

(1) Position control

The total number of pulses required to move the specified distance is obtained in the following manner.

$$\left(\begin{array}{l} \text{Total number of pulses required} \\ \text{to move the specified distance} \end{array} \right) = \frac{\left(\begin{array}{l} \text{Specified distance} \end{array} \right)}{\left(\begin{array}{l} \text{Movement amount of the} \\ \text{machine (load) side when} \\ \text{the motor rotates once} \end{array} \right)} \times \left(\begin{array}{l} \text{Number of pulses} \\ \text{required for the motor} \\ \text{to rotate once} \end{array} \right)$$

* The number of pulses required for the motor to rotate once is the "encoder resolution" described in the motor catalog specification list.

When this total number of pulses is issued from the QD72P3C3 to the drive unit, the control, for which the workpiece to move the specified distance, can be realized. The machine side movement amount when one pulse is issued to the drive unit is called the "movement amount per pulse". This value is the minimum value for the workpiece to move, and is also the degree of accuracy for electrical positioning control.

(2) Speed control

Although the above "total number of pulses" is an element required to control the movement amount, speed must be controlled to perform equal-speed operation. This "speed" is controlled by the "pulse frequency" output from the QD72P3C3 to the drive unit.

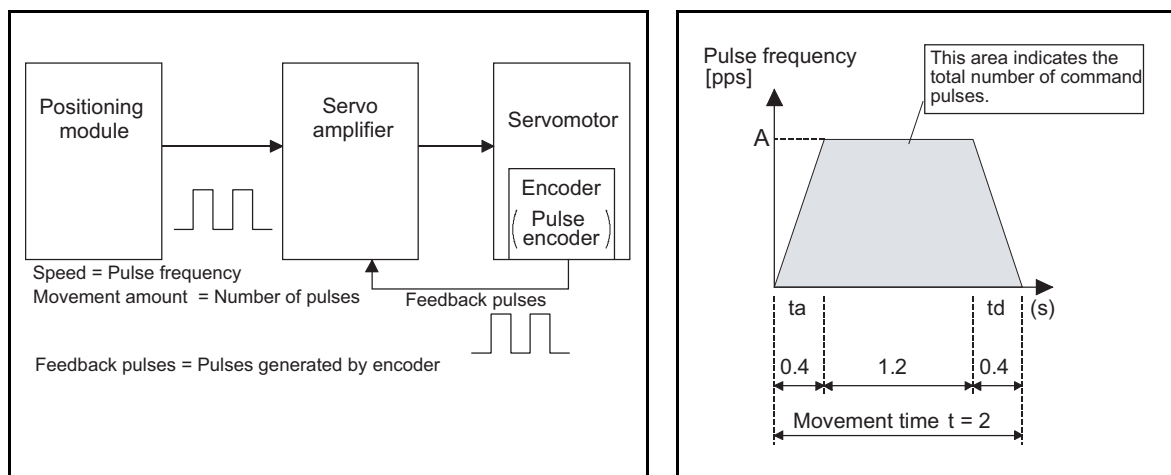

Figure 1.1 Relationship between position control and speed control

POINT

- The "movement amount per pulse" is the value determined on the machine side. (Refer to Section 1.2.2.)
- The QD72P3C3 uses the "total number of pulses" to control the position and the "pulse frequency" to control the speed.

1.2.2 Design outline of positioning control system

The following describes the outline of the operation of positioning control system, using the QD72P3C3.

(1) Positioning control system using the QD72P3C3

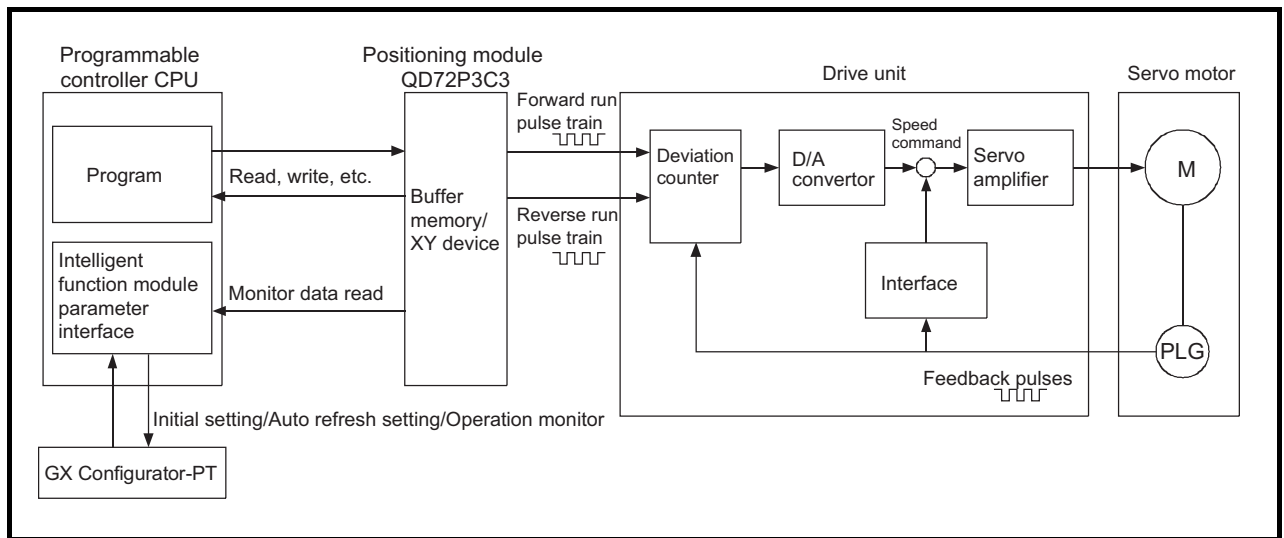

Figure 1.2 Outline of the operation of positioning control system using the QD72P3C3

(a) Positioning control operation using the QD72P3C3

- 1) The QD72P3C3 outputs a pulse train.
When the pulse train is output from the QD72P3C3, the deviation counter of the drive unit accumulates the input pulses.
The D/A converter converts these accumulated pulses (droop pulses) into DC analog voltage, which serves as a speed command for the servomotor.
- 2) The servomotor starts its rotation upon reception of the speed command from the drive unit.
As the servomotor rotates, the pulse encoder (PLG) attached to the servomotor generates feedback pulses in proportion to the rotation frequency. The generated feedback pulses are fed back to the drive unit, and reduce the droop pulses of the deviation counter.
The deviation counter maintains a certain number of droop pulses so that the servomotor keeps its rotation.
- 3) When the QD72P3C3 stops the output of commanded pulse train, the servomotor decelerates as the droop pulses of the deviation counter decrease and finally stops when the droop pulse count drops to zero.
That is, the servomotor rotation speed is proportional to the pulse frequency, while the servomotor rotation angle is proportional to the number of commanded pulses output from the QD72P3C3.
When the movement amount per pulse is given, the overall movement amount can be determined in proportion to the number of pulses in the pulse train. The rotation speed (feed speed) of the servomotor, on the other hand, can be determined by the pulse frequency.

(b) Output pulse from the QD72P3C3

- 1) As shown in Figure 1.3, the number of pulses in a pulse train is small at the start, and then the number increases as the servomotor accelerates and its speed approaches the command speed.
- 2) The pulse frequency stabilizes once the speed reaches the command speed.
- 3) To decelerate the servomotor, the QD72P3C3 decreases the number of pulses in a pulse train before it finally stops the output.

The servomotor actually decelerates and stops its rotation with little delay from the command pulse stop.

This time difference in deceleration and stop between pulse output from the QD72P3C3 and the servomotor is called the "stop settling time" and necessary for ensuring stopping accuracy.

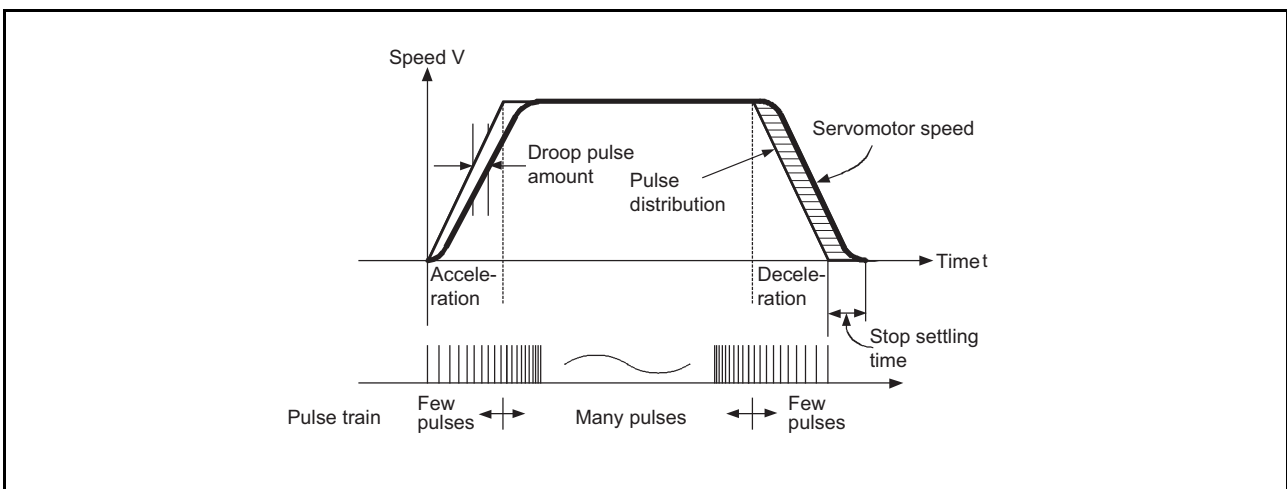

Figure 1.3 Output pulse from the QD72P3C3

(2) Movement amount and speed in a system using ball screw

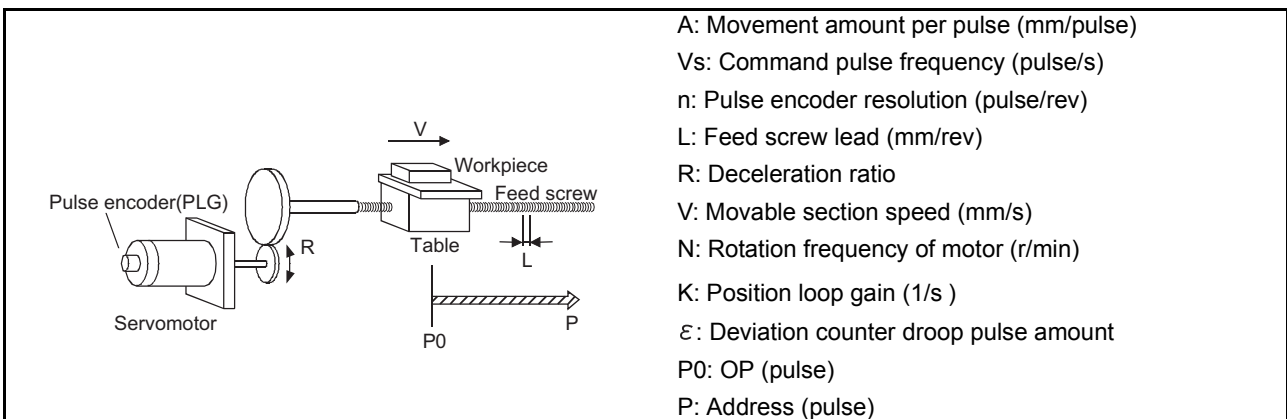

Figure 1.4 System using ball screw

In the system shown in Figure 1.4, the movement amount per pulse, command pulse frequency, and deviation counter droop pulse amount are determined in the following manner.

1) Movement amount per pulse

The movement amount per pulse is determined by the feed screw lead, deceleration ratio, and pulse encoder resolution.

The movement amount, therefore, will be: (Number of pulses output) × (Movement amount per pulse).

$$A = \frac{L}{R \times n} \text{ [mm/pulse]}$$

2) Command pulse frequency

The command pulse frequency is determined by the movable section speed and movement amount per pulse.

$$V_s = \frac{V}{A} \text{ [pulse/s]}$$

3) Deviation counter droop pulse amount

The deviation counter droop pulse amount is determined by the command pulse frequency and position loop gain.

$$\varepsilon = \frac{V_s}{K} \text{ [pulse]}$$

1.2.3 Design outline of counter function

The following describes the outline of the count operation, using the counter function of the QD72P3C3.

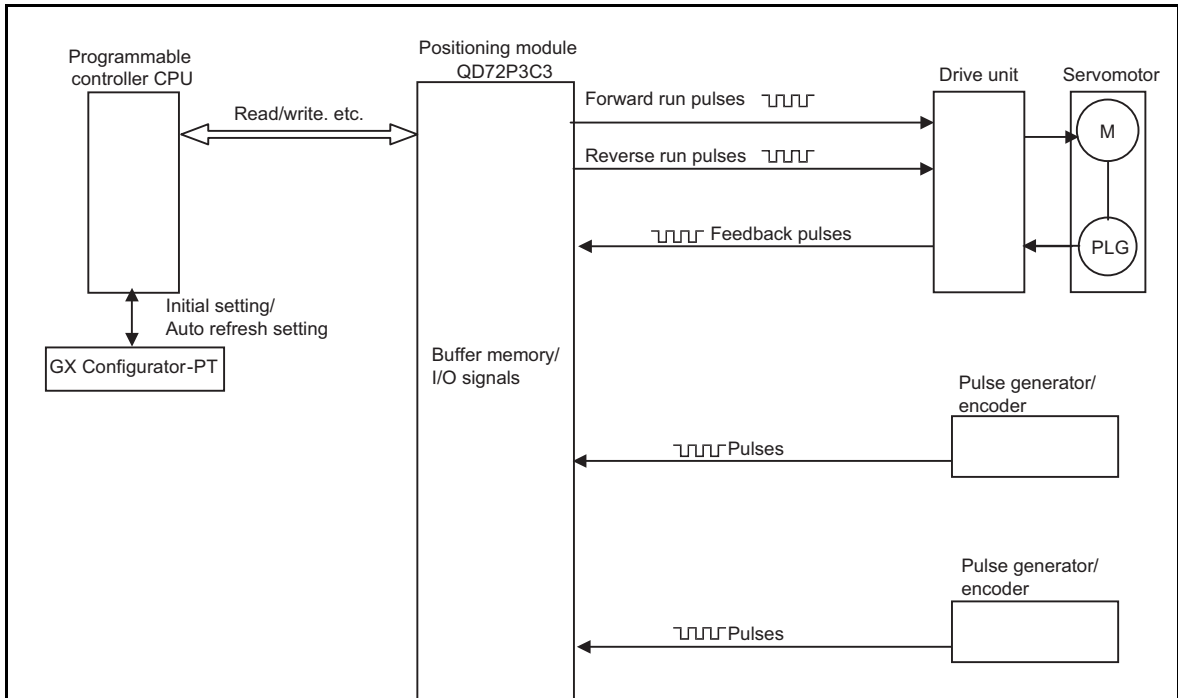

1) Pulses input to the QD72P3C3 are counted.

- Counting pulses can be performed separately from positioning control.
- Counting feedback pulses enables positioning control, checking the actual position at the same time.

The positioning address and count value can be synchronized with the use of following functions.

Count value selection function at OPR	Refer to Section 8.4.
Current feed value, count value simultaneous change function	Refer to Section 12.7.

2) The status of I/O signals and buffer memory of the QD72P3C3 can be checked with the sequence program.

The start/stop and preset of count operation can also be performed.

1.2.4 Communicating signals between QD72P3C3 and each module

The following shows the outline of the signal communication between the QD72P3C3 and programmable controller CPU, peripheral (GX Configurator-PT), and drive unit. (A peripheral is connected to the programmable controller CPU, and communicates signals with the QD72P3C3 via the programmable controller CPU.)

For details of each I/O signals, refer to CHAPTER 3.

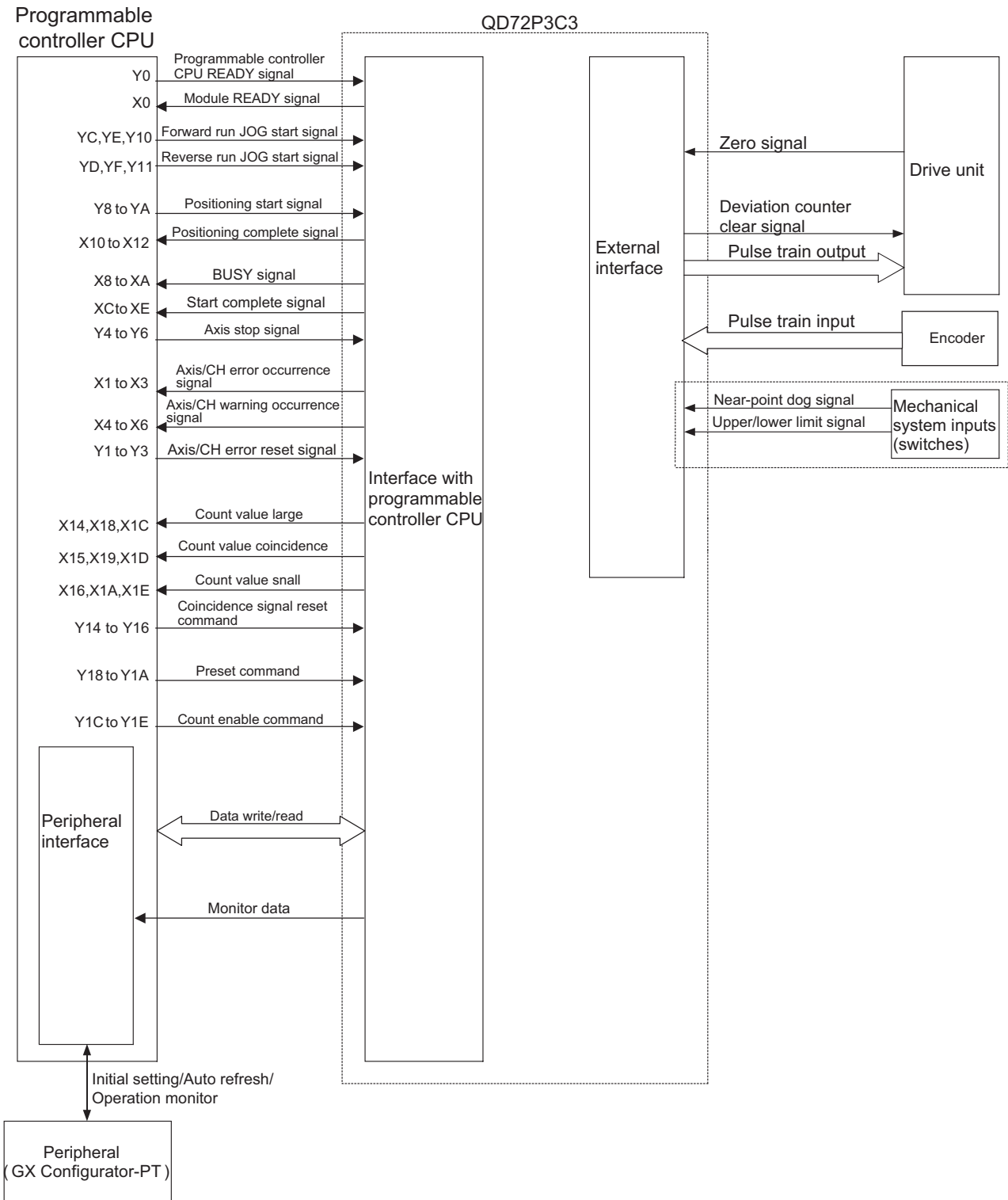

(1) QD72P3C3 → Programmable controller CPU

The QD72P3C3 and programmable controller CPU communicate the following data via the base unit.

Direction Communication	QD72P3C3 → Programmable controller CPU	Programmable controller CPU → QD72P3C3
Control signal	Signals indicate the QD72P3C3 status: <ul style="list-style-type: none"> •Module READY signal (X0) •Axis/CH error occurrence signal (X1 to X3) •Axis/CH warning occurrence signal (X4 to X6) •BUSY signal (X8 to XA) •Start complete signal (XC to XE) •Positioning complete signal (X10 to X12) •Count value large (X14, X18, and X1C) •Count value coincidence (X15, X19, and X1D) •Count value small (X16, X1A, and X1E) 	Signals related to commands: <ul style="list-style-type: none"> •Programmable controller CPU READY signal (Y0) •Axis/CH error reset signal (Y1 to Y3) •Axis stop signal (Y4 to Y6) •Positioning start signal (Y8 to YA) •Forward run JOG start signal (YC, YE, and Y10) •Reverse run JOG start signal (YD, YF, and Y11) •Coincidence signal reset command (Y14 to Y16) •Preset command (Y18 to Y1A) •Count enable command (Y1C to Y1E)
Data (read/write)	<ul style="list-style-type: none"> •Parameter •JOG data •Positioning data •Control data •Monitor data 	<ul style="list-style-type: none"> •Parameter •JOG data •Positioning data •Control data

(2) QCPU → Peripheral (GX Configurator-PT)

The QCPU and peripheral communicates the following data. (For details, refer to CHAPTER 6.)

Direction Communication	QCPU → Peripheral	Peripheral → QCPU
Data	-	<ul style="list-style-type: none"> •Initial setting •Auto refresh setting
Operation monitor	<ul style="list-style-type: none"> •Monitor data (QD72P3C3 buffer memory/XY devices) 	-

(3) QD72P3C3 → Drive unit

The QD72P3C3 and drive unit communicate the following data via the external device connector.

Direction Communication	QD72P3C3 → Drive unit	Drive unit → QD72P3C3
Control signal	Signals related to commands: <ul style="list-style-type: none"> •Deviation counter clear signal (CLEAR) 	Signals indicate OP: <ul style="list-style-type: none"> •Zero signal (PG0)
Pulse train	<ul style="list-style-type: none"> •Pulse train output (PULSE F/PULSE R) 	-

(4) Encoder → QD72P3C3

The input signals from the encoder are input to the QD72P3C3 via the external device connector.

Encoder	•Pulse train input (CH A/CH B)
---------	--------------------------------

(5) Mechanical system inputs (switches) → QD72P3C3

The input signals from the mechanical system inputs (switches) are input to the QD72P3C3 via the external device connector.

Mechanical system input (switch)	•Near-point dog signal (DOG) •Upper/lower limit signal (FLS/RLS)
----------------------------------	---

1.3 Basic Operation of Positioning Control

1.3.1 Outline of control start

The following flowchart shows the outline of each control start.

* Assume that module installation and required settings for system configuration have already been prepared.

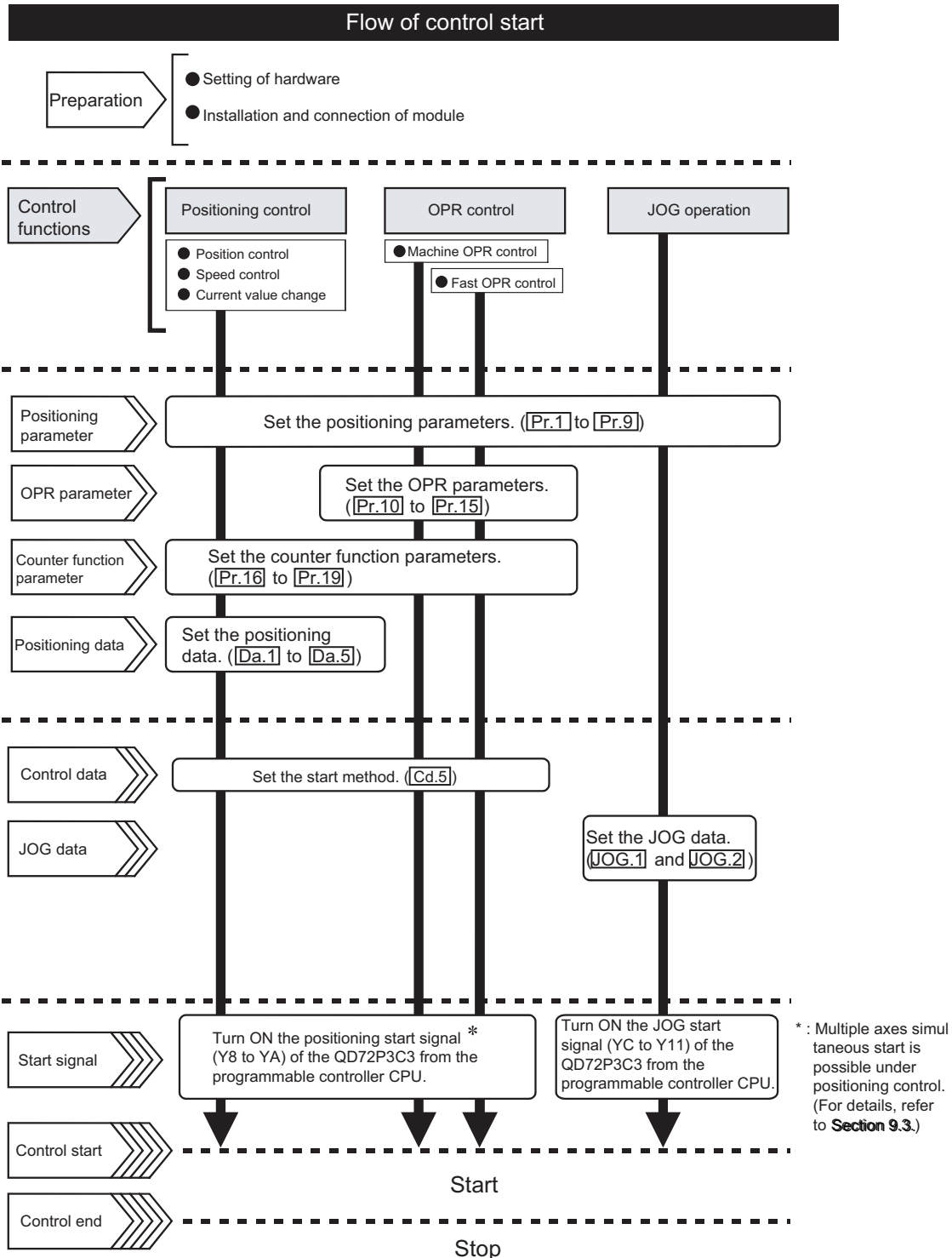

1.3.2 Outline of control stop

A control stops in the following cases:

- (1) Each control ended normally.
- (2) An error occurred in the programmable controller CPU.
- (3) An error occurred in the QD72P3C3.
- (4) The axis stop signal (Y4 to Y6) from the programmable controller CPU is turned ON.

The following table shows the outline of the stop processing performed in the cases above.

(Except the case (1) where each control ended normally.)

Cause of stop	Stopped axis	Axis operation status after stop (Md.4)	Stop processing		
			OPR control	Positioning control	JOG operation
Programmable controller CPU error	All axes	Error	Deceleration stop		
QD72P3C3 error	Axis by axis	Error	Deceleration stop		
The "axis stop signal (Y4 to Y6)" from the programmable controller CPU is turned ON.	Axis by axis	Stopped	Deceleration stop		

■ Stop after multiple axes concurrent start under positioning control

The axes started will not stop simultaneously. The stop command (axis stop signal (Y4 to Y6) ON) must be issued to each axis.

CHAPTER2 SYSTEM CONFIGURATION

This chapter describes the system configuration of the QD72P3C3.

2.1 General Image of System

The following is the general configuration including the QD72P3C3, programmable controller CPU, and peripheral, etc.

(Numbers in the figure correspond to the ones in the table in "Section 2.2 Component List" on the next page.

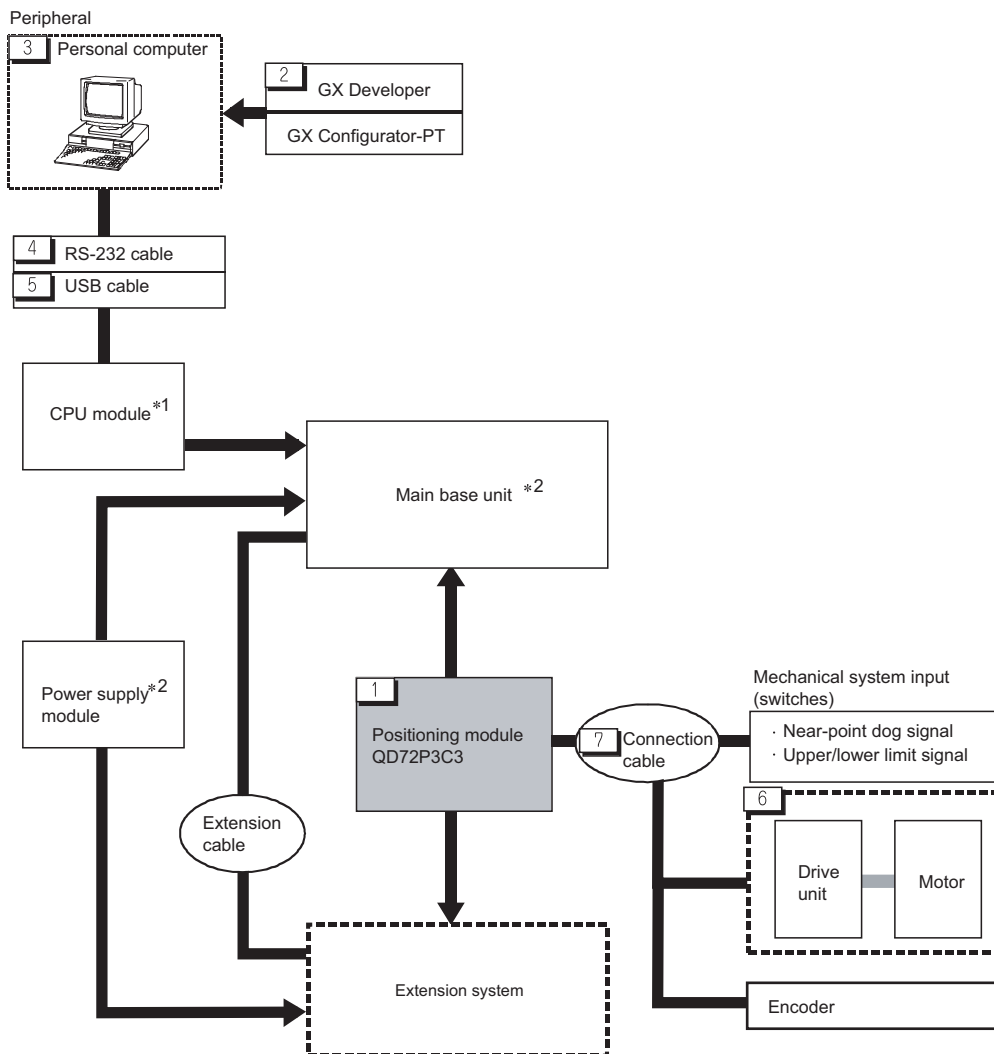

Remark

- *1 For available CPU modules, refer to "Section 2.3 Applicable System".
- *2 For available base units and power supply modules, refer to the User's Manual for the CPU module.

2.2 Component List

A positioning system using the QD72P3C3 consists of the following components.

No.	Product name	Model	Remarks
1	Positioning module	QD72P3C3	-
2	GX Developer	SW□D5C-GPPW-E	For details, refer to the GX Developer Operating Manual and "CHAPTER 6 UTILITY PACKAGE (GX Configurator-PT)".
	GX Configurator-PT	SW□D5C-QPTU-E	
3	Personal computer	IBM-PC/AT-compatible personal computer	(User preparation) For details, refer to the GX Developer Operating Manual.
4	RS-232 cable	QC30R2	(User preparation) RS-232 cable for connecting CPU module with IBM-PC/AT-compatible personal computer For details, refer to the GX Developer Operating Manual.
5	USB cable	-	(User preparation) USB cable for connecting CPU module with IBM-PC/AT-compatible personal computer For details, refer to the GX Developer Operating Manual.
6	Drive unit	-	(User preparation) For details, refer to the manual for the drive unit.
7	Connection cable (for connection between the QD72P3C3 and drive unit)	-	(User preparation) Cable for connecting the QD72P3C3, drive unit, and encoder (Install them with reference to the manual for the connected device and Section 3.5.2.)

2.3 Applicable Systems

This section describes applicable systems.

(1) Applicable modules and base units, and No. of modules

(a) When mounted with a CPU module

The table below shows the CPU modules and base units applicable to the QD72P3C3 and quantities for each CPU model.

Depending on the combination with other modules or the number of mounted modules, power supply capacity may be insufficient.

Pay attention to the power supply capacity before mounting modules, and if the power supply capacity is insufficient, change the combination of the modules.

Applicable CPU module		No. of modules ^{*1}	Base unit ^{*2}			
CPU type	CPU model		Main base unit	Extension base unit		
Programmable controller CPU	Basic model QCPU ^{*3}	Q00JCPU	Up to 8	○	○	
		Q00CPU	Up to 24			
		Q01CPU				
	High Performance model QCPU	Q02CPU	Up to 64	○	○	
		Q02HCPU				
		Q06HCPU				
		Q12HCPU				
	Process CPU	Q25HCPU	Up to 64	○	○	
		Q02PHCPU				
		Q06PHCPU				
		Q12PHCPU				
	Redundant CPU	Q25PHCPU	Up to 53 ^{*4 *5}	×	○	
		Q12PRHCPU				
	Universal model QCPU	Q25PRHCPU	Up to 64	○	○	
		Q00UJCPU				Up to 8
		Q00UCPU				Up to 24
		Q01UCPU				
		Q02UCPU				Up to 36
		Q03UDCPU				Up to 64
Q04UDHCPU						
Q06UDHCPU						
Q10UDHCPU						
Q13UDHCPU						
Q20UDHCPU						
Q26UDHCPU						

○: Applicable ×: N/A

Applicable CPU module		No. of modules ^{*1}	Base unit ^{*2}	
CPU type	CPU model		Main base unit	Extension base unit
Programmable controller CPU	Universal model QCPU	Q03UDECPU	○	○
		Q04UDEHCPU		
		Q06UDEHCPU		
		Q10UDEHCPU		
		Q13UDEHCPU		
		Q20UDEHCPU		
		Q26UDEHCPU		
		Q50UDEHCPU		
		Q100UDEHCPU		
Safety CPU	QS001CPU	N/A	× ^{*6}	
C Controller module	Q06CCPU-V	Up to 64	○	○
	Q06CCPU-V-B			
	Q12DCCPU-V			

○: Applicable ×: N/A

- * 1 The CPU modules can be mounted within the range of each number of I/O points.
- * 2 The CPU modules can be mounted on any I/O slots of the base units.
- * 3 For the coincidence detection interrupt function, use the Basic model QCPU module of function version B or later.
- * 4 The dedicated instructions are not supported.
- * 5 The coincidence detection interrupt function is not supported.
- * 6 The safety CPU cannot be connected with extension base units.

Remark

For the use of the C Controller module, refer to the C Controller Module User's Manual.

1 PRODUCT OUTLINE

2 SYSTEM CONFIGURATION

3 SPECIFICATIONS AND FUNCTIONS

4 DATA USED FOR POSITIONING CONTROL

5 PROCEDURES AND SETTINGS BEFORE OPERATION

6 UTILITY PACKAGE (GX Configurator-PT)

7 SEQUENCE PROGRAM USED FOR POSITIONING

8 OPR CONTROL

(b) Mounting to a MELSECNET/H remote I/O station

The table below shows the network modules and base units applicable to the QD72P3C3 and quantities for each network module model.

Depending on the combination with other modules or the number of mounted modules, power supply capacity may be insufficient.

Pay attention to the power supply capacity before mounting modules, and if the power supply capacity is insufficient, change the combination of the modules.

Applicable network module ^{*3*4}	No. of modules ^{*1}	Base unit ^{*2}	
		Main base unit of remote I/O station	Extension base unit of remote I/O station
QJ72LP25-25	Up to 64	○	○
QJ72LP25G			
QJ72LP25GE			
QJ72BR15			

○: Applicable ×: N/A

- * 1 Limited within the range of I/O points for the network module.
- * 2 Can be installed to any I/O slot of a base unit.
- * 3 The coincidence detection interrupt function is not supported.
- * 4 The dedicated instructions are not supported.

Remark

The Basic model QCPU or C Controller module cannot create the MELSECNET/H remote I/O network.

(2) Support of the multiple CPU system

When using the QD72P3C3 in a multiple CPU system, refer to the following manual first.

- QCPU User's Manual (Multiple CPU System)

(a) Supported QD72P3C3

The function version of the QD72P3C3 has been "B" from the first release product, supporting the multiple CPU system.

(b) Intelligent function module parameters

Write intelligent function module parameters to only the control CPU of the QD72P3C3.

(3) Supported software packages

Relation between the system containing the QD72P3C3 and software package is shown in the following table.

GX Developer is necessary when using the QD72P3C3.

		Software version																
		GX Developer	GX Configurator-PT	GX Works2														
Q00J/Q00/Q01CPU	Single CPU system	Version 7 or later	Version 1.23Z or later	Version 1.10N or later														
	Multiple CPU system	Version 8 or later																
Q02/Q02H/Q06H/Q12H/Q25HCPU	Single CPU system	Version 4 or later		Version 1.23Z or later	Version 1.08J or later													
	Multiple CPU system	Version 6 or later																
Q02PH/Q06PHCPU	Single CPU system	Version 8.68W or later			Version 1.23Z or later	Not supported												
	Multiple CPU system																	
Q12PH/Q25PHCPU	Single CPU system	Version 7.10L or later					Version 1.23Z or later	Not supported										
	Multiple CPU system																	
Q12PRH/Q25PRHCPU	Redundant CPU system	Version 8.45X or later							Version 1.23Z or later	Version 1.08J or later								
Q00UJ/Q00U/Q01UCPU	Single CPU system	Version 8.78G or later									Version 1.23Z or later	Version 1.08J or later						
	Multiple CPU system																	
Q02U/Q03UD/Q04UDH/Q06UDHCPU	Single CPU system	Version 8.48A or later				Version 1.23Z or later							Version 1.08J or later					
	Multiple CPU system																	
Q10UDH/Q20UDHCPU	Single CPU system	Version 8.78G or later						Version 1.23Z or later						Version 1.08J or later				
	Multiple CPU system																	
Q13UDH/Q26UDHCPU	Single CPU system	Version 8.62Q or later													Version 1.23Z or later	Version 1.08J or later		
	Multiple CPU system																	
Q03UDE/Q04UDEH/Q06UDEH/Q13UDEH/Q26UDEHCPU	Single CPU system	Version 8.68W or later	Version 1.23Z or later														Version 1.08J or later	
	Multiple CPU system																	
Q10UDEH/Q20UDEHCPU	Single CPU system	Version 8.78G or later		Version 1.23Z or later														Version 1.08J or later
	Multiple CPU system																	
Q50UDEH/Q100UDEHCPU	Single CPU system	Not supported			Version 1.23Z or later													
	Multiple CPU system																	
When mounted to the MELSECNET/H remote I/O station		Version 6 or later					Version 1.23Z or later											

2.4 Using QD72P3C3 with Redundant CPUs

This section explains the use of the QD72P3C3 with the Redundant CPUs.

(1) Dedicated instruction

The dedicated instruction cannot be used.

(2) GX Configurator-PT connection

GX Configurator-PT cannot be used when the Redundant CPUs are accessed from GX Developer via an intelligent function module on an extension base unit.

Connect a personal computer with a communication path indicated below.

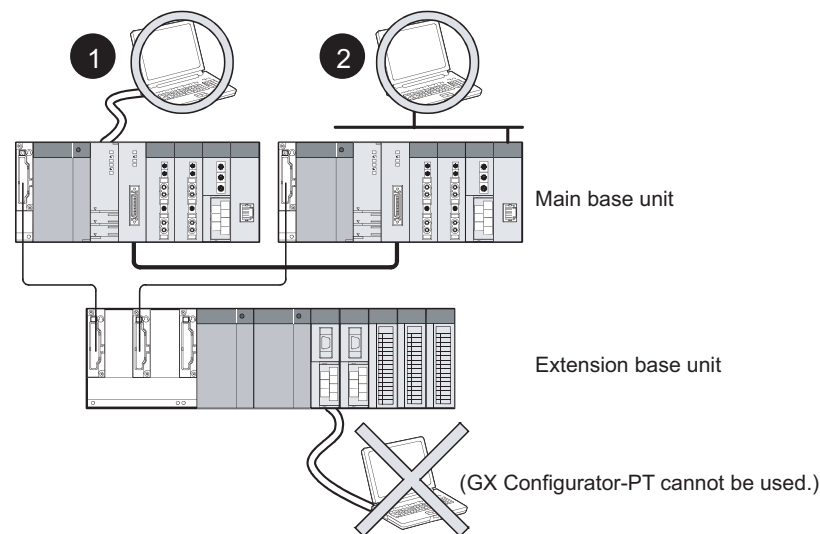

1 Direct connection to the CPU

2 Connection through an intelligent function module on the main base unit
(Through Ethernet module, MELSECNET/H module, or CC-Link module)

2.5 About Use of the QD72P3C3 with the MELSECNET/H Remote I/O Station

This section describes when using the QD72P3C3 in the MELSECNET/H remote I/O station.

(1) The number of mountable QD72P3C3 modules when using the MELSECNET/H remote I/O station

For the number of mountable modules, refer to Section 2.3 (1)(b).

(2) Restrictions on using the MELSECNET/H remote I/O station

(a) When using the QD72P3C3 in the MELSECNET/H remote I/O station, since delay time due to link scan time occurs, fully assure that the target system is controlled normally.

Example) Depending on the duration while the positioning complete signal (X10 to X12) is ON, the ON status cannot be detected due to link scan time delay.

(b) The coincidence detection interrupt function is not supported.

(c) The dedicated instructions are not supported.

2.6 Checking Function Version, Serial Number and Software Version

(1) Checking the function version and serial number of the QD72P3C3

The serial number and function version of the QD72P3C3 are described in the rating plate, on the front part of the module, or displayed in the system monitor of GX Developer.

(a) Checking the rating plate located on the side of the QD72P3C3

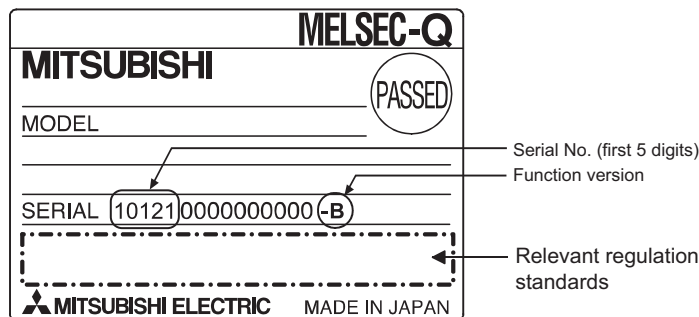

(b) Checking the front part of the module

The serial number and function version described in the rating plate can be shown on the front (bottom part) of the module.

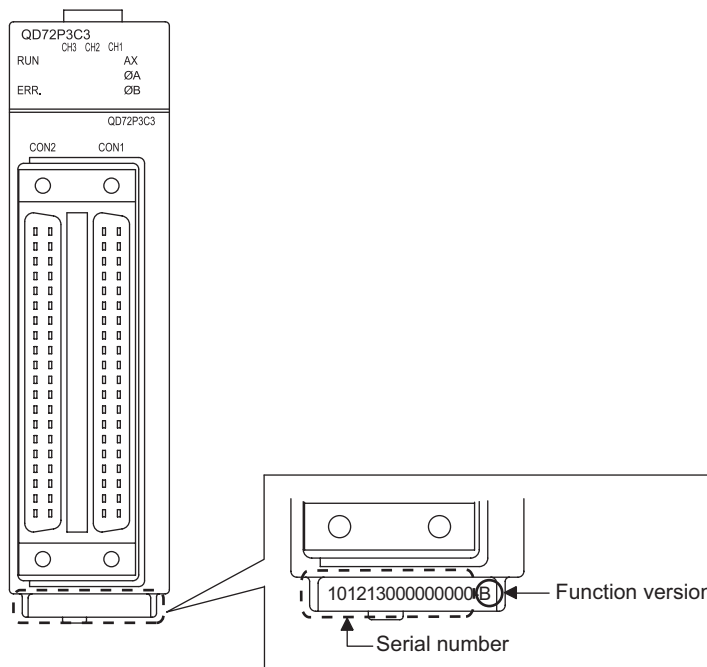

Remark

Printing of serial number on the front of the module has been started since December 2008. Products manufactured during switching period may not have the serial number on the front of the module.

- (c) Checking the system monitor (Product Information List)
 To display the system monitor, select [Diagnostics] → [System monitor] and click the Product Information List button of GX Developer.

Slot	Type	Series	Model name	Points	I/O No.	Master PLC	Serial No.	Ver.	Product No.
PLC	PLC	Q	Q06UDHCPU	-	-	-	110130000000000	B	091013092955015-B
0-0	Intelli.	Q	QD72P3C3	32pt	0000	-	111020000000000	B	-
0-1	-	-	None	-	-	-	-	-	-
0-2	-	-	None	-	-	-	-	-	-
0-3	-	-	None	-	-	-	-	-	-

- 1) Displaying the product No.
 Since the QD72P3C3 does not support the display function, “-” is displayed in the “Product No.” field.

POINT

The serial number displayed on the Product Information List screen of GX Developer may differ from that on the rating plate and on the front of the module.

- The serial number on the rating plate and front part of the module indicates the management information of the product.
- The serial number displayed on the Product Information List dialog box of GX Developer indicates the function information of the product. The function information of the product is updated when a new function is added.

(2) Checking the software version of GX Configurator-PT

The software version of GX Configurator- PT can be checked by selecting [Help]-[Product information] of GX Developer.

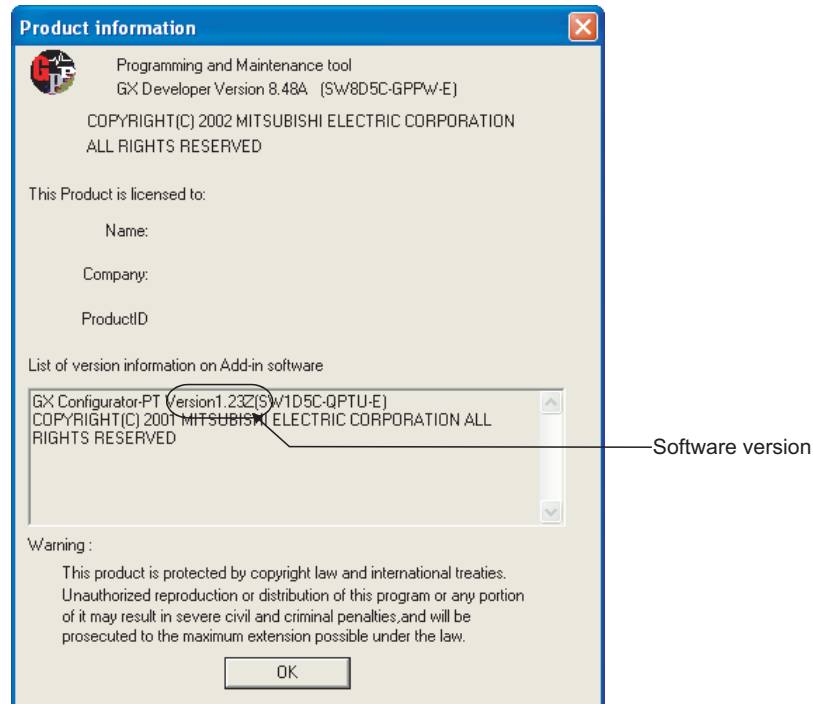

CHAPTER3 SPECIFICATIONS AND FUNCTIONS

This chapter describes the performance specifications and functions of the QD72P3C3, and the specifications of the I/O signals to the programmable controller CPU and external device.

For general specifications of the QD72P3C3, refer to the User's Manual for the CPU module.

3.1 Performance Specifications

Item		Specification		
Positioning control	Number of axes	3 axes		
	Interpolation function	None (Artificial linear interpolation by concurrent start is available.)		
	Control method	PTP (Point To Point) control, speed control		
	Control unit	pulse		
	Positioning data	1 data/axis (Set it with GX Configurator-PT or sequence program.)		
	Positioning control method	Incremental system, absolute system		
	Positioning control range	[Incremental system]	-1073741824 to 1073741823 pulse (when using linear counter)	
		[Absolute system]	-1073741824 to 1073741823 pulse (when using ring counter) 0 to 1073741823 pulse	
	Speed command	1 to 100000pulse/s		
	Acceleration/deceleration processing	Trapezoidal acceleration/deceleration		
	ACC/DEC time	1 to 5000ms		
	Start time	Position control, speed control	1-axis start	1ms
			3-axes concurrent start	1ms
	Pulse output method	Open collector output		
Maximum output pulse	100kpps			
Maximum connection distance between drive units	2m			
Counter function*	Counting speed (max.)	100kPPS		
	Number of channels	3 channels		
	Counting range	31-bit signed binary		
		[Linear counter]	-1073741824 to 1073741823	
		[Ring counter]	0 to 1073741823	
External connection system	40-pin connector			
Applicable wire size	0.3mm ² or lower (for the A6CON1 and A6CON4), AWG24 (for the A6CON2)			
Peripheral/compatible utility package	GX Configurator-PT (sold separately)			
Data backup	None			
External device connector	A6CON1, A6CON2, A6CON4 (sold separately)			
5VDC internal current consumption	0.57A			
Number of occupied I/O points	32 points (I/O assignment: Intelligent 32 points)			
Weight	0.16kg			

* For electrical specifications of count input signals, refer to Section 3.5.1 Electrical specifications of I/O signals.

3.2 Function List

The following table lists the functions of the QD72P3C3.

Control method/function name		Description	Reference
OPR control	Machine OPR control	Mechanically establishes the positioning control start point using a near-point dog or stopper.	Section 8.2
	Fast OPR control	Performs positioning control to the OP address ([Md.1] Current feed value) stored in the QD72P3C3 using machine OPR control.	Section 8.3
	Count value selection function at OPR	Stores the OP address to "[Md.3] Count value" when OPR is completed.	Section 8.4
Positioning control	Position control (1-axis linear control)	Performs positioning control to the position specified to the address set in the positioning data or with the movement amount.	Section 9.2.2
	Speed control	Continuously outputs a pulse corresponding to the "[Da.4] Command speed" set in positioning data.	Section 9.2.3
	Current value change	Changes the "[Md.1] Current feed value" to the address set in the positioning data.	Section 9.2.4
JOG operation		Outputs a pulse to drive unit while the JOG start signal (YC to Y11) is ON.	CHAPTER 10
Auxiliary function	Speed limit function	If the command speed exceeds the "[Pr.4] Speed limit value" during control, this function limits the command speed to within the "[Pr.4] Speed limit value" setting range.	Section 11.2
	Speed change function	Changes the speed during the constant speed of speed control or JOG operation.	Section 11.3
	Software stroke limit function	When a command is issued to the outside of the upper limit/lower limit stroke limit setting range, which are set in the parameters, this function will not execute operation for that command.	Section 11.4
	Hardware stroke limit function	Executes the deceleration stop by the limit switch connected to the QD72P3C3.	Section 11.5
	ACC/DEC process function	Adjusts the acceleration/deceleration processing of control.	Section 11.6

3 SPECIFICATIONS AND FUNCTIONS

Control method/function name	Description	Reference	
Counter function	Linear counter function	Can count from -1073741824 to 1073741823 and detect an overflow when the count range is overrun.	Section 12.2
	Ring counter function	Counts repeatedly from 0 to the "[Pr.16] Ring counter upper limit value". Note) When using the ring counter function, the positioning control range is from 0 to 1073741823 (pulse).	Section 12.3
	Count enable function	Counts pulses while the count enable command (Y1C to Y1E) is ON.	Section 12.4
	Coincidence detection function	By presetting the "[Cd.7] Coincidence detection point setting", this function outputs ON/OFF signal as compared to the "[Md.3] Count value".	Section 12.5
	Preset function	Rewrites the "[Md.3] Count value" to an arbitrary value.	Section 12.6
	Current feed value, count value simultaneous change function	Changes the "[Md.1] Current feed value" and the "[Md.3] Count value" to the same value at presetting or current value change.	Section 12.7
Common function	External I/O signal logic switching function	Changes the external I/O signal logic to match the externally connected device. It can be changed by making the intelligent function module setting.	Section 13.2
	External I/O signal monitor function	Monitors the external I/O signal status by using GX Developer.	Section 13.3

1	PRODUCT OUTLINE
2	SYSTEM CONFIGURATION
3	SPECIFICATIONS AND FUNCTIONS
4	DATA USED FOR POSITIONING CONTROL
5	PROCEDURES AND SETTINGS BEFORE OPERATION
6	UTILITY PACKAGE (GX Configurator-PT)
7	SEQUENCE PROGRAM USED FOR POSITIONING
8	OPR CONTROL

3.3 Specifications of I/O Signals with Programmable Controller CPU

3.3.1 List of I/O signals with programmable controller CPU

The QD72P3C3 uses 32 input points and 32 output points for exchanging data with the programmable controller CPU.

The I/O signals when the QD72PC3 is mounted in slot 0 of the main base unit are shown below.

Device X refers to the signals input from the QD72P3C3 to the programmable controller CPU, and device Y refers to the signals output from the programmable controller CPU to the QD72P3C3.

Signal direction: QD72P3C3 → programmable controller CPU		Signal direction: Programmable controller CPU → QD72P3C3	
Device No.	Signal name	Device No.	Signal name
X0	Module READY signal	Y0	Programmable controller CPU READY signal
X1	Axis 1/CH1 error occurrence signal	Y1	Axis 1/CH1 error reset signal
X2	Axis 2/CH2 error occurrence signal	Y2	Axis 2/CH2 error reset signal
X3	Axis 3/CH3 error occurrence signal	Y3	Axis 3/CH3 error reset signal
X4	Axis 1/CH1 warning occurrence signal	Y4	Axis 1 stop signal
X5	Axis 2/CH2 warning occurrence signal	Y5	Axis 2 stop signal
X6	Axis 3/CH3 warning occurrence signal	Y6	Axis 3 stop signal
X7	Use prohibited	Y7	Use prohibited
X8	Axis 1 BUSY signal	Y8	Axis 1 positioning start signal
X9	Axis 2 BUSY signal	Y9	Axis 2 positioning start signal
XA	Axis 3 BUSY signal	YA	Axis 3 positioning start signal
XB	Use prohibited	YB	Use prohibited
XC	Axis 1 Axis 1 start complete signal	YC	Axis 1 forward run JOG start signal
XD	Axis 2 start complete signal	YD	Axis 1 reverse run JOG start signal
XE	Axis 3 start complete signal	YE	Axis 2 forward run JOG start signal
XF	Use prohibited	YF	Axis 2 reverse run JOG start signal
X10	Axis 1 positioning complete signal	Y10	Axis 3 forward run JOG start signal
X11	Axis 2 positioning complete signal	Y11	Axis 3 reverse run JOG start signal
X12	Axis 3 positioning complete signal	Y12	Use prohibited
X13	Use prohibited	Y13	Use prohibited
X14	CH1 count value large	Y14	CH1 coincidence signal reset command
X15	CH1 count value coincidence	Y15	CH2 coincidence signal reset command
X16	CH1 count value small	Y16	CH3 coincidence signal reset command
X17	Use prohibited	Y17	Use prohibited
X18	CH2 count value large	Y18	CH1 preset command
X19	CH2 count value coincidence	Y19	CH2 preset command
X1A	CH2 count value small	Y1A	CH3 preset command
X1B	Use prohibited	Y1B	Use prohibited
X1C	CH3 count value large	Y1C	CH1 count enable command
X1D	CH3 count value coincidence	Y1D	CH2 count enable command
X1E	CH3 count value small	Y1E	CH3 count enable command
X1F	Use prohibited	Y1F	Use prohibited

☒ IMPORTANT

X07, X0B, X0F, X13, X17, X1B, X1F, Y07, Y0B, Y12, Y13, Y17, Y1B, Y1F are used by the system, and cannot be used by the user.

If used, the operations of the QD72P3C3 are not ensured.

3 SPECIFICATIONS AND FUNCTIONS

3.3.2 Details of input signal (QD72P3C3 → programmable controller CPU)

The following table shows the details of input signals.

Device No.	Signal name		Description
X0	Module READY signal		<p>OFF: Not prepared/ watch dog timer error ON: Prepared</p> <p>(1) When the programmable controller CPU READY signal (Y0) is turned from OFF to ON, the parameter setting range is checked. If no error is found, this signal turns ON. (When the error occurrence signal (X1 to X3) is ON, this signal does not turn ON even if the programmable controller CPU READY signal (Y0) is turned from OFF to ON.) (2) When the programmable controller CPU READY signal (Y0) is turned OFF, this signal turns OFF. (3) When a watch dog timer error occurs, this signal turns OFF. (4) This signal is used for an interlock of sequence programs.</p>
X1 X2 X3	Axis 1/CH1 Axis 2/CH2 Axis 3/CH3	Error occurrence signal	<p>OFF: No error ON: Error occurrence</p> <p>(1) Module error occurrence status is displayed for each axis (each CH). (2) This signal turns OFF when the error reset signal (Y1 to Y3) is turned ON. (3) Error code can be checked by "[Md.5]Axis/CH error code" for each axis (each CH).</p>
X4 X5 X6	Axis 1/CH1 Axis 2/CH2 Axis 3/CH3	Warning occurrence signal	<p>OFF: No warning ON: warning occurrence</p> <p>(1) Module warning occurrence status is displayed for each axis (each CH). (2) This signal turns OFF when the axis/CH error reset signal (Y1 to Y3) is turned ON. (3) Warning code can be checked by "[Md.7] Axis/CH warning code" for each axis (each CH).</p>
X8 X9 XA	Axis 1 Axis 2 Axis 3	BUSY signal*1	<p>OFF: Not BUSY ON: BUSY</p> <p>(1) This signal turns ON at the start of positioning control, OPR control or JOG operation. It turns OFF after positioning control stops (This signal remains ON during positioning control). (2) This signal turns OFF at error or stop.</p>
XC XD XE	Axis 1 Axis 2 Axis 3	Start complete signal	<p>OFF: Start incomplete ON: Start complete</p> <p>(1) This signal turns ON when the positioning start signal (Y8 to YA) is turned ON and the QD72P3C3 starts the positioning control process. (The signal turns ON during OPR control. The signal does not turn ON during JOG operation.)</p>
X10 X11 X12	Axis 1 Axis 2 Axis 3	Positioning complete signal*2	<p>OFF: Positioning incomplete ON: Positioning complete</p> <p>(1) This signal turns ON for a time set in "[Pr.6] Positioning complete signal output time" after position control is completed for each axis. (The signal does not turn ON when "[Pr.6] Positioning complete signal output time" is 0. (2) While this signal is ON, starting positioning control (including OPR control) or JOG operation causes the signal to be OFF. (3) This signal does not turn ON at the completion of JOG operation. (4) This signal does not turn ON if the position control is stopped midway.</p>

Device No.	Signal name		Description
X14 X18 X1C	CH1 CH2 CH3	Count value large	OFF: Count value \leq Coincidence detection point setting, ON: Count value $>$ Coincidence detection point setting (1) This signal turns ON when "[Md.3] Count value" $>$ "[Cd.7] Coincidence detection point setting".
X15 X19 X1D	CH1 CH2 CH3	Count value coincidence	OFF: Count value not coincided, ON: Count value coincided (1) This signal latches at ON when "[Md.3] Count value" = "[Cd.7] Coincidence detection point setting". (2) This signal turns OFF when the coincidence signal reset request is turned ON.
X16 X1A X1E	CH1 CH2 CH3	Count value small	OFF: Count value \geq Coincidence detection point setting, ON: Count value $<$ Coincidence detection point setting (1) This signal turns ON when "[Md.3] Count value" $<$ "[Cd.7] Coincidence detection point setting".

❗ IMPORTANT

- *1: The BUSY signal (X8 to XA) turns ON even when position control of movement amount 0 is performed. However, since the ON time is short, the ON status may not be detected in the sequence program.
- *2: Position control completion of the QD72P3C3 refers to the point when the pulse output from the QD72P3C3 is completed. Thus, even if the positioning complete signal (X10 to X12) of the QD72P3C3 turns ON, the system may continue operation.

3.3.3 Details of output signals (programmable controller CPU → QD72P3C3)

The following table shows the details of output signals.

Device No.	Signal name		Description
Y0	Programmable controller CPU READY signal		<p>OFF: Programmable controller CPU READY OFF, ON: Programmable controller CPU READY ON</p> <p>(1) This signal notifies the QD72P3C3 that the programmable controller CPU is normal.</p> <ul style="list-style-type: none"> It is turned ON/OFF with the sequence program. This signal is turned ON during positioning control, OPR control and JOG operation. <p>(2) When changing parameters or OPR data, turn OFF this signal.</p> <p>(3) The QD72P3C3 processes the following when this signal is turned from OFF to ON.</p> <ul style="list-style-type: none"> The parameter and OPR data setting range is checked. The module READY signal (X0) turns ON. <p>(4) The QD72P3C3 processes the following when this signal is turned from ON to OFF. In these cases, the OFF time should be set to 100ms or more.</p> <ul style="list-style-type: none"> The module READY signal (X0) turns OFF. The operating axis stops.
Y1 Y2 Y3	Axis 1/CH1 Axis 2/CH2 Axis 3/CH3	Error reset signal	<p>OFF: Error reset not requested ON: Error reset requested</p> <p>(1) When the axis/CH error or the axis/CH warning occurs, turning ON this signal clears the error, and "[Md.5] Axis/CH error code" and "[Md.7] Axis/CH warning code" are cleared.</p> <p>(2) By turning ON this signal during error occurrence, "[Md.4] Axis operation status" changes from "Error" to "Standby".</p>
Y4 Y5 Y6	Axis 1 Axis 2 Axis 3	Axis stop signal	<p>OFF: Axis stop not requested ON: Axis stop requested</p> <p>(1) When this signal is turned ON, the OPR control, positioning control and JOG operation stop. In these cases, the ON time should be set to 4ms or more. If ON time is less than 4ms, the OPR control, positioning control and JOG operation may not stop.</p> <p>(2) Turning ON this signal during operation decelerates the axis to a stop. At this time, "[Md.4] Axis operation status" changes from "Deceleration (Axis stop signal (Y4 to Y6) ON)" to "Stopped".</p>
Y8 Y9 YA	Axis 1 Axis 2 Axis 3	Positioning start signal	<p>OFF: Positioning start not requested ON: Positioning start requested</p> <p>(1) OPR control and positioning control are started.</p> <p>(2) The positioning start becomes valid at the rising edge, and the operation is started.</p> <p>(3) When this signal is turned ON during BUSY, the "Start during operation" warning (warning code: 10) occurs.</p>
YC YD YE YF Y10 Y11	Axis 1 forward run Axis 1 reverse run Axis 2 forward run Axis 2 reverse run Axis 3 forward run Axis 3 reverse run	JOG start signal	<p>OFF: JOG not started ON: JOG started</p> <p>(1) While this signal is ON, JOG operation is performed at the "[JOG.1] JOG speed".</p> <p>(2) When this signal is turned from ON to OFF, it decelerates to stop.</p>

Device No.	Signal name		Description
Y14 Y15 Y16	CH1 CH2 CH3	Coincidence signal reset command	OFF: Coincidence signal reset not commanded ON: Coincidence signal reset commanded (1) This signal is turned ON when resetting the count value coincidence (X15, X19, and X1D).
Y18 Y19 Y1A	CH1 CH2 CH3	Preset command	OFF: Preset not commanded ON: Preset commanded (1) On the rising edge of this signal, "[Cd.6] Preset value setting" is set to "[Md.3] Count value".
Y1C Y1D Y1E	CH1 CH2 CH3	Count enable command	OFF: Count enable not commanded ON: Count enable commanded (1) By turning ON this signal, the counting operation is started.

3.4 List of Buffer Memory Addresses

The following is a list of buffer memory addresses.

In addition, for the details, such as a setting value, of each buffer memory, refer to "Chapter 4 DATA USED FOR POSITIONING CONTROL".

Item	Setting value, setting range	Factory default value	Buffer memory address for setting			Reference
			Axis 1/ CH1	Axis 2/ CH2	Axis 3/ CH3	
Pr.1 Software stroke limit upper limit value	-1073741824 to 1073741823 (pulse)	1073741823	0	100	200	Section 4.2
			1	101	201	
Pr.2 Software stroke limit lower limit value	-1073741824 to 1073741823 (pulse)	-1073741824	2	102	202	
			3	103	203	
Pr.3 Current feed value during speed control	0: No update 1: Update	0	5	105	205	
Pr.4 Speed limit value	1 to 100000 (pulse/s)	8000	6	106	206	
			7	107	207	
Pr.5 Bias speed at start	1 to 100000 (pulse/s)	1	8	108	208	
			9	109	209	
Pr.6 Positioning complete signal output time	0 to 65535 (ms)	300	10	110	210	
Pr.7 Deviation counter clear signal output time	0: 1ms 1: 2ms 2: 10ms 3: 20ms	2	11	111	211	
Pr.9 Current feed value, count value simultaneous change function selection	0: Values not changed simultaneously 1: Count value changed together at current value change 2: Current feed value changed together at preset 3: Values changed both at current value change and at preset	0	13	113	213	
Pr.10 OPR method	0: OPR method 1) Near-point dog method 1: OPR method 2) Stopper 3	0	20	120	220	
Pr.11 OPR direction	0: Forward direction 1: Reverse direction	0	21	121	221	
Pr.12 OP address	-1073741824 to 1073741823 (pulse)	0	22	122	222	
			23	123	223	
Pr.13 OPR speed	1 to 100000 (pulse/s)	1	24	124	224	
			25	125	225	
Pr.14 Creep speed	1 to 100000 (pulse/s)	1	26	126	226	
			27	127	227	
Pr.15 ACC/DEC time at OPR	1 to 5000 (ms)	1000	28	128	228	
Pr.16 Ring counter upper limit value	0 to 1073741823	0	30	130	230	
			31	131	231	
Pr.17 Positioning range upper limit value	0 to 1073741823 (pulse)	0	32	132	232	
			33	133	233	
Pr.18 Coincidence detection setting	0: Coincidence detection not request 1: Coincidence detection requested	0	34	134	234	
Pr.19 Count value selection at OPR	0: OP address not set to count value 1: OP address set to count value	0	35	135	235	

3 SPECIFICATIONS AND FUNCTIONS

Item	Setting value, setting range	Factory default value	Buffer memory address for setting			Reference
			Axis 1/ CH1	Axis 2/ CH2	Axis 3/ CH3	
JOG.1 JOG speed	1 to 100000 (pulse/s)	1	40 41	140 141	240 241	Section 4.3
JOG.2 JOG ACC/DEC time	1 to 5000 (ms)	1000	42	142	242	
Cd.1 New speed value	1 to 100000 (pulse/s)	1	50 51	150 151	250 251	Section 4.6
Cd.2 ACC/DEC time at speed change	1 to 5000 (ms)	1000	52	152	252	
Cd.3 Speed change request	0: Speed change not requested 1: Speed change requested	0	54	154	254	
Cd.4 OPR request flag OFF request	0: OPR request flag OFF complete 1: OPR request flag OFF requested	0	55	155	255	
Cd.5 Start method	0: Positioning control 9000: Machine OPR control 9001: Fast OPR control	0	56	156	256	
Cd.6 Preset value setting	-1073741824 to 1073741823	0	60 61	160 161	260 261	
Cd.7 Coincidence detection point setting	-1073741824 to 1073741823	0	62 63	162 163	262 263	
Md.1 Current feed value	-	0	70 71	170 171	270 271	
Md.2 Current speed	-	0	72 73	172 173	272 273	
Md.3 Count value	-	0	74 75	174 175	274 275	
Md.4 Axis operation status	-	0	76	176	276	
Md.5 Axis/CH error code	-	0	77	177	277	
Md.7 Axis/CH warning code	-	0	78	178	278	
Md.7 Status	-	0002H	79	179	279	
Md.8 External I/O signal	-	0000H	80	180	280	
Da.1 Operation pattern	0: Positioning start (independent) 5000 : Positioning start (continuous)	0	90	190	290	
Da.2 Control method	0: No control method 1: 1-axis linear control (ABS) 2: 1-axis linear control (INC) 3: Speed control (forward run) 4: Speed control (reverse run) 5: Current value change	0	91	191	291	
Da.3 ACC/DEC time	1 to 5000 (ms)	1000	92	192	292	
Da.4 Command speed	1 to 100000 (pulse/s)	1	94 95	194 195	294 295	
Da.5 Positioning address/ movement amount	-1073741824 to 1073741823 (pulse)	0	96 97	196 197	296 297	

1 PRODUCT OUTLINE

2 SYSTEM CONFIGURATION

3 SPECIFICATIONS AND FUNCTIONS

4 DATA USED FOR POSITIONING CONTROL

5 PROCEDURES AND SETTINGS BEFORE OPERATION

6 UTILITY PACKAGE (GX Configurator-PT)

7 SEQUENCE PROGRAM USED FOR POSITIONING

8 OPR CONTROL

3.5 Specifications of I/O Interfaces with External Device

3.5.1 Electrical specifications of I/O signals

(1) Input specifications

(a) Input specifications of external input device for positioning

Signal name	Rated input voltage/current	Operating voltage range	ON voltage/current	OFF voltage/current	Input resistance	Response time
Zero signal (PG0)	5VDC/18mA	4.5 to 5.5VDC	2.7VDC or more/ 5.5mA or more	1.0VDC or less/ 0.5mA or less	Approx. 390Ω	0.1ms or less
	<p>•The minimum pulse width is as follows.</p> <p>The diagram shows a pulse signal. The pulse width is labeled as 0.1ms or more. The rise time and fall time are both labeled as 3μs or less. The signal transitions from OFF to ON and back to OFF.</p>					
Near-point dog signal (DOG) Upper limit signal (FLS) Lower limit signal (RLS)	24VDC/5mA	19.2 to 26.4VDC	17.5VDC or more/ 3.0mA or more	7.0VDC or less/ 0.9mA or less	Approx. 6.8kΩ	1ms or less

(b) Input specifications for the counter function

Signal name	Rated input voltage/current	Operating voltage range	ON voltage/current	OFF voltage/current	Input resistance	Response time
5VDC	5VDC/18mA	4.5 to 5.5V	2.7VDC or more/ 5.5mA or more	1.0VDC or less/ 0.5mA or less	Approx. 390Ω	1 μs or less
24VDC	24VDC/2 to 6mA	21.6 to 26.4V	21.6VDC or more/ 2mA or more	5VDC or less/ 0.1mA or less	Approx. 3900 +390Ω	1 μs or less

•Input pulse can be selected from 1 multiple of 2 phases, 2 multiples of 2 phases, 4 multiples of 2 phases, and CW/CCW.
Set it in pulse input mode of "Intelligent function module switch setting" (refer to Section 5.6).

Pulse input mode	For addition count	For subtraction count
CW/CCW		
1 multiples of 2 phases		
2 multiples of 2 phases		
4 multiples of 2 phases		

Phase A pulse input
(CH A_5V/CH A_24V)

Phase B pulse input
(CH B_5V/CH B_24V)

•The minimum count pulse width is as follows.

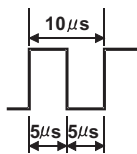

Duty ratio 50%

(Minimum phase difference for 2-phase input: 2.5 μs)

•The rise/fall time is as follows.

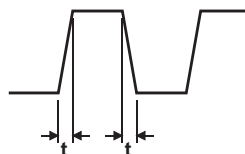

Rise/fall time	100k
	Both 1 and 2-phase input
t = 1.25 μ or less	100kPPS
t = 2.5 μ or less	100kPPS
t = 25 μ or less	10kPPS
t = 500 μ	-

•Input pulse can be selected from 1 multiple of 2 phases, 2 multiples of 2 phases, 4 multiples of 2 phases, and CW/CCW.
Set it in pulse input mode of "Intelligent function module switch setting" (refer to Section 5.6).

(2) Output specifications

(a) Input specifications of external input device for positioning

Signal name	Rated load voltage	Operating load voltage range	Max. load current/inrush current	Max. voltage drop at ON	Leakage current at OFF	Response time																							
Pulse output F (PUSE F) (CW/PULSE) Pulse output R (PUSE R) (CCW/SIGN)	5 to 24VDC	4.75 to 30VDC	50mA/point / 200mA 10ms or less	5VDC (TYP)	0.1mA or less	-																							
	<ul style="list-style-type: none"> •Set pulse output mode and pulse output logic selection with "Intelligent function module switch setting" (refer to Section 5.6). •The following table shows the relationship of "Pulse output mode" and "Pulse output logic selection" with pulse output. <table border="1"> <thead> <tr> <th rowspan="3">Pulse output mode</th> <th colspan="4">Pulse output logic selection</th> </tr> <tr> <th colspan="2">Positive logic</th> <th colspan="2">Negative logic</th> </tr> <tr> <th>Forward run</th> <th>Reverse run</th> <th>Forward run</th> <th>Reverse run</th> </tr> </thead> <tbody> <tr> <td>CW/CCW</td> <td></td> <td></td> <td></td> <td></td> </tr> <tr> <td>PULSE/SIGN</td> <td></td> <td></td> <td></td> <td></td> </tr> </tbody> </table>						Pulse output mode	Pulse output logic selection				Positive logic		Negative logic		Forward run	Reverse run	Forward run	Reverse run	CW/CCW					PULSE/SIGN				
	Pulse output mode	Pulse output logic selection																											
Positive logic		Negative logic																											
Forward run		Reverse run	Forward run	Reverse run																									
CW/CCW																													
PULSE/SIGN																													
<p>The rise/fall time and duty ratio are as the table on the next page.*</p>																													
Deviation counter clear (CLEAR)	5 to 24VDC	4.75 to 30VDC	0.1A/point 0.4A, 10ms or less	1VDC (TYP) 2.5VDC (MAX)	0.1mA or less	2ms or less (resistance load), pulse width is from 1 to 20ms.																							

3 SPECIFICATIONS AND FUNCTIONS

*: Pulse rise/fall time (unit tr,tf: μ s Duty:%) ... Ambient air temperature is assumed to be ordinary temperature.

Load voltage (V)		26.4					
Cable length (m)		1			2		
Load current (mA)	Pulse speed (kpps)	tr (Rise)	tf (Fall)	Duty	tr (Rise)	tf (Fall)	Duty
2	100	2.341	0.156	44.76	2.824	0.162	42.45
	10	2.849	0.169	49.1	3.727	0.182	49.08
5	100	1.101	0.176	49.7	1.487	0.188	48.37
	10	1.114	0.174	49.6	1.516	0.190	49.83
10	100	0.511	0.188	51.4	0.753	0.203	50.89
	10	0.522	0.187	50.15	0.745	0.204	50.09
20	100	0.268	0.218	52.37	0.379	0.233	52.18
	10	0.262	0.218	50.24	0.376	0.234	50.22
50	100	0.098	0.344	53.34	0.140	0.359	53.33
	10	0.097	0.347	50.34	0.135	0.361	50.34

Load voltage (V)		4.75					
Cable length (m)		1			2		
Load current (mA)	Pulse speed (kpps)	tr (Rise)	tf (Fall)	Duty	tr (Rise)	tf (Fall)	Duty
2	100	0.510	0.107	50.87	0.712	0.113	50.38
	10	0.492	0.107	50.08	0.680	0.112	50.04
5	100	0.207	0.117	51.8	0.289	0.120	51.74
	10	0.201	0.113	50.19	0.288	0.119	50.18
10	100	0.097	0.129	52.29	0.138	0.131	52.28
	10	0.098	0.128	50.23	0.131	0.130	50.23
20	100	0.039	0.160	52.75	0.055	0.159	52.80
	10	0.038	0.159	50.28	0.054	0.158	50.28
50	100	0.015	0.255	53.41	0.016	0.258	53.47
	10	0.014	0.254	50.34	0.016	0.259	50.36

1 PRODUCT OUTLINE

2 SYSTEM CONFIGURATION

3 SPECIFICATIONS AND FUNCTIONS

4 DATA USED FOR POSITIONING CONTROL

5 PROCEDURES AND SETTINGS BEFORE OPERATION

6 UTILITY PACKAGE (GX Configurator-PT)

7 SEQUENCE PROGRAM USED FOR POSITIONING

8 OPR CONTROL

3 SPECIFICATIONS AND FUNCTIONS

3.5.2 Signal layout for external device connector

The specifications of the connector section, which is the I/O interface for the QD72P3C3 and external device, are shown below.

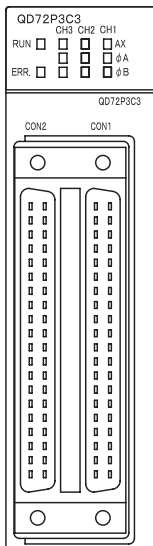

Pin layout	CON2 (for axis 3)				CON1 (for axes 1 and 2)			
	Pin No.	Signal name	Pin No.	Signal name	Pin No.	Signal name	Pin No.	Signal name
B20	NC	A20	CH3A_24V	B20	CH2A_24V	A20	CH1A_24V	
B19	NC	A19	CH3A_5V	B19	CH2A_5V	A19	CH1A_5V	
B18	NC	A18	CH3A COM ^{*1}	B18	CH2A COM ^{*1}	A18	CH1A COM ^{*1}	
B17	NC	A17	CH3B_24V	B17	CH2B_24V	A17	CH1B_24V	
B16	NC	A16	CH3B_5V	B16	CH2B_5V	A16	CH1B_5V	
B15	NC	A15	CH3B COM ^{*2}	B15	CH2B COM ^{*2}	A15	CH1B COM ^{*2}	
B14	NC	A14	PG03	B14	PG02	A14	PG01	
B13	NC	A13	PG03 COM ^{*3}	B13	PG02 COM ^{*3}	A13	PG01 COM ^{*3}	
B12	NC	A12	CLEAR3	B12	CLEAR2	A12	CLEAR1	
B11	NC	A11	CLEAR3 COM ^{*4}	B11	CLEAR2 COM ^{*4}	A11	CLEAR1 COM ^{*4}	
B10	NC	A10	DOG3	B10	DOG2	A10	DOG1	
B9	NC	A9	COM1-3 ^{*5}	B9	COM1-3 ^{*5}	A9	COM1-3 ^{*5}	
B8	NC	A8	FLS3	B8	FLS2	A8	FLS1	
B7	NC	A7	COM1-3 ^{*5}	B7	COM1-3 ^{*5}	A7	COM1-3 ^{*5}	
B6	NC	A6	RLS3	B6	RLS2	A6	RLS1	
B5	NC	A5	COM1-3 ^{*5}	B5	COM1-3 ^{*5}	A5	COM1-3 ^{*5}	
B4	NC	A4	PULSE F3	B4	PULSE F2	A4	PULSE F1	
B3	NC	A3	PULSE COM1-3 ^{*6}	B3	PULSE COM1-3 ^{*6}	A3	PULSE COM1-3 ^{*6}	
B2	NC	A2	PULSE R3	B2	PULSE R2	A2	PULSE R1	
B1	NC	A1	PULSE COM1-3 ^{*6}	B1	PULSE COM1-3 ^{*6}	A1	PULSE COM1-3 ^{*6}	

* 1 Common for CH□A_5V, CH□A_24V (□ indicates any of channel numbers 1 to 3.)

* 2 Common for CH□B_5V, CH□B_24V (□ indicates any of channel numbers 1 to 3.)

* 3 Common for PG0□ (□ indicates any of axis numbers 1 to 3.)

* 4 Common for CLEAR□ (□ indicates any of axis numbers 1 to 3.)

* 5 Common for DOG□, FLS□, RLS□ (□ indicates any of axis numbers 1 to 3.)

* 6 Common for PULSE F□, PULSE R□ (□ indicates any of axis numbers 1 to 3.)

3.5.3 List of I/O signal details

The details of each signal for the QD72P3C3 external device connector are shown below.

Signal name	Pin No.		Symbol	Signal details (Negative logic is selected by external I/O signal logic selection)
Zero signal	A14	B14	PG0	<ul style="list-style-type: none"> Input the zero signal for machine OPR control. Use the encoder's zero signal and so on. Use this signal when " [Pr.10] OPR method" is the stopper 3 and the OPR complete is input from an external device. The zero signal is detected at turning from OFF to ON.
Zero signal common	A13	B13	PG0 COM	<ul style="list-style-type: none"> Common for zero signal
Near-point dog signal	A10	B10	DOG	<ul style="list-style-type: none"> This signal is used for detecting the near-point dog during machine OPR control. The near-point dog signal is detected at turning from OFF to ON.
Upper limit signal	A8	B8	FLS	<ul style="list-style-type: none"> Input this signal from the limit switch, which is set to the stroke upper limit position. Turning OFF this signal stops positioning.
Lower limit signal	A6	B6	RLS	<ul style="list-style-type: none"> Input this signal from the limit switch, which is set to the stroke lower limit position. Turning OFF this signal stops positioning.
Common	A9 A7 A5	B9 B7 B5	COM	<ul style="list-style-type: none"> Common for near-point dog signal, upper limit signal, and lower limit signal
Deviation counter clear	A12	B12	CLEAR	<ul style="list-style-type: none"> This signal is output during machine OPR control. The output time of the deviation counter clear is set in " [Pr.7] Deviation counter clear signal input time". Use the drive unit that can reset the droop pulse amount in the internal deviation counter when the QD72P3C3 turns this signal ON. (Note) The deviation counter clear is a signal output by the QD72P3C3 during machine OPR control. It cannot output randomly.
Deviation counter clear common	A11	B11	CLEAR COM	<ul style="list-style-type: none"> Common for deviation counter clear
Pulse output F	A4	B4	PULSE F	<ul style="list-style-type: none"> This signal is used to output command pulses to the open collector compatible unit. CW/CCW mode: CW, PULSE/SIGN mode: PULSE
Pulse output R	A2	B2	PULSE R	<ul style="list-style-type: none"> This signal is used to output command pulses to the open collector compatible unit. CW/CCW mode: CCW, PULSE/SIGN mode: SIGN
Pulse output common	A3 A1	B3 B1	PULSE COM	<ul style="list-style-type: none"> Common for pulse output F and pulse output R
Phase A pulse input 24V	A20	B20	CHA_24V	<ul style="list-style-type: none"> Phase A pulse input for 24V
Phase A pulse input 5V	A19	B19	CHA_5V	<ul style="list-style-type: none"> Phase A pulse input for 5V
Phase A common	A18	B18	CHA COM	<ul style="list-style-type: none"> Common for phase A pulse
Phase B pulse input 24V	A17	B17	CHB_24V	<ul style="list-style-type: none"> Phase B pulse input for 24V
Phase B pulse input 5V	A16	B16	CHB_5V	<ul style="list-style-type: none"> Phase B pulse input for 5V
Phase B common	A15	B15	CHB COM	<ul style="list-style-type: none"> Common for phase B pulse

3.5.4 Internal circuit of I/O interface

The following shows the schematic diagram of the internal circuit of the interface for external device connection of the QD72P3C3.
(for axis 1)

I/O classification	External wiring	Pin No.	Internal circuit	Signal name	
Input (for positioning)		A14		Zero signal	PG0 1
		A13		Zero signal common	PG0 COM 1
		A10		Near-point dog signal	DOG 1
		A8		Upper limit signal	FLS 1
		A6		Lower limit signal	RLS 1
Output (for positioning)		A9		Common	COM 1-3
		A12		Deviation counter clear	CLEAR 1
		A11		Deviation counter clear common	CLEAR COM 1
		A4		Pulse output F	PULSE F 1
		A2		Pulse output R	PULSE R 1
Input (for counter function)	A3		Pulse output common	PULSE COM 1-3	
	A20			Phase A pulse input 24V	CH1A_24V
	A19			Phase A pulse input 5V	CH1A_5V
	A18	Phase A common	CH1A COM		
	A17		Phase B pulse input 24V	CH1B_24V	
	A16		Phase B pulse input 5V	CH1B_5V	
A15	Phase B common	CH1B COM			

* Common terminal is available to both positive common and negative common (COM).

(1) Input signal ON/OFF status**(a) Input signal ON/OFF status**

The input signal ON/OFF status is defined by the external wiring and logic setting. The following shows an example of the near-point dog signal (DOG). (The other input signals also perform the same operations as the near-point dog signal (DOG).)

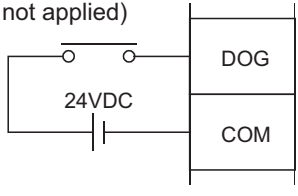
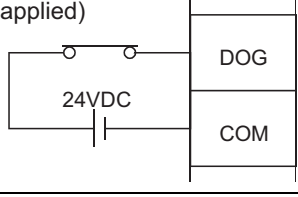
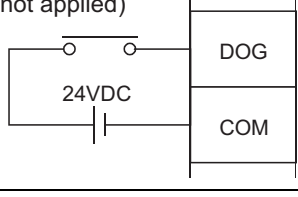
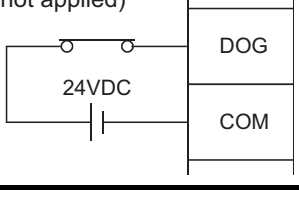
Logic setting ^{*1}	External wiring ^{*1,*2}	ON/OFF status of the near-point dog signal (DOG) as seen from the QD72P3C3
Negative logic (Default value)	(Voltage not applied) 	OFF
	(Voltage applied) 	ON
Positive logic	(Voltage not applied) 	ON
	(Voltage not applied) 	OFF

* 1 Set the logic setting using "Intelligent function module switch setting". For details of the setting contents, refer to Section 5.6.

* 2 When using the upper limit signal (FLS) and/or the lower limit signal (RLS), always wire them/it as the normally closed contact in the negative logic setting. Turning OFF this signal stops positioning.

(b) Logic setting and internal circuit

In the QD72P3C3, the case where the internal circuit (photocoupler) is OFF in the negative logic setting is defined as "input signal OFF".

Reversely, the case where the internal circuit (photocoupler) is OFF in the positive logic setting is defined as "input signal ON".

(Photocoupler ON/OFF status)

- When voltage is not applied: Photocoupler OFF
- When voltage is applied: Photocoupler ON

CHAPTER4 DATA USED FOR POSITIONING CONTROL

This chapter describes the specifications of the data to be set to the QD72P3C3.

4.1 Data Types

4.1.1 Parameters and data required for control

The parameters and data required to perform control with the QD72P3C3 include the following three types of data: "setting data", "monitor data", and "control data".

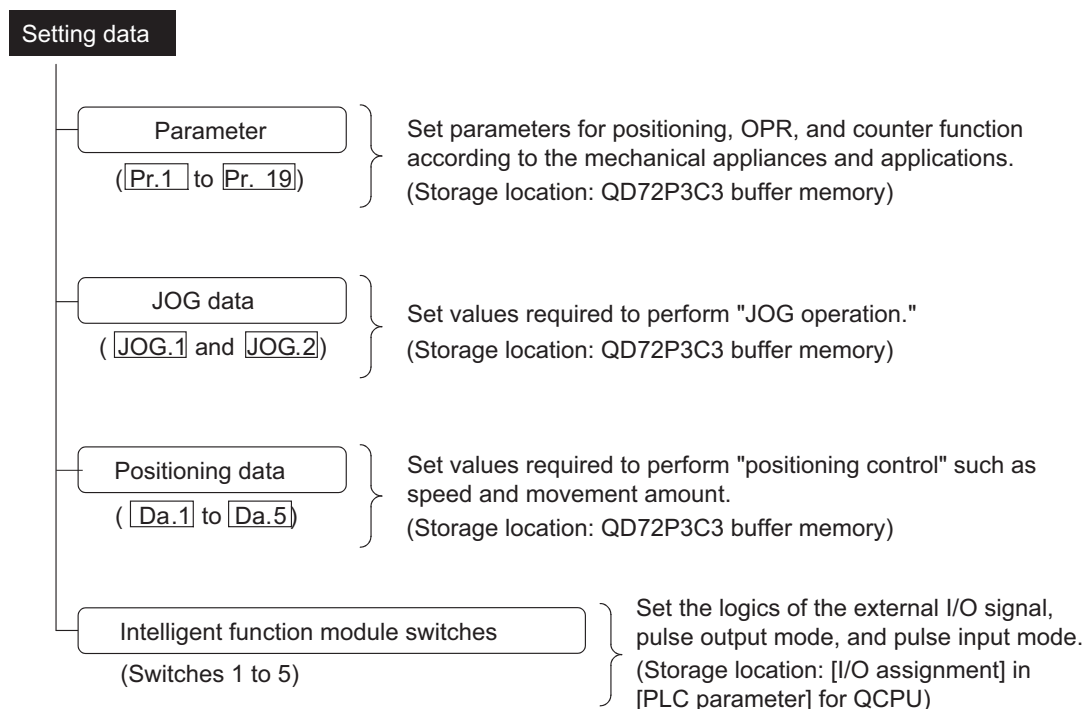

- The parameters become valid when the programmable controller CPU READY signal (Y0) is turned from OFF to ON.
- The JOG data and positioning data become valid when JOG operation and positioning control starts, respectively.
- Use GX Developer to set the intelligent function module switches. (For details, refer to "Section 5.6 Intelligent Function Module Switch Setting".)

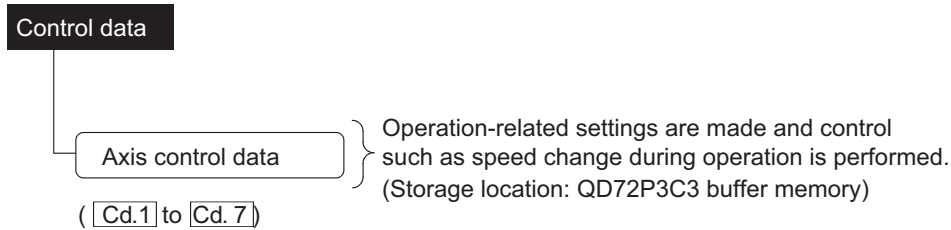
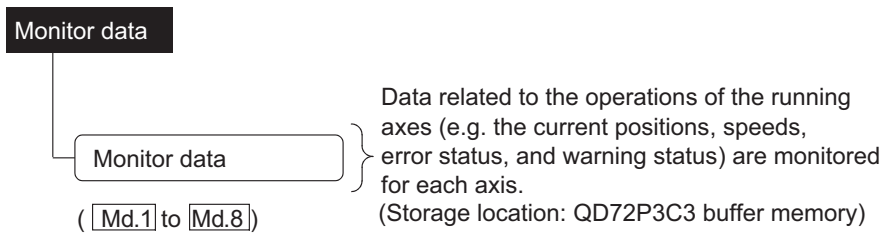

■ How to set "setting data"

Setting item \ Means	Sequence program	GX Configurator-PT	GX Developer	GX Works2
Parameter	○	○ (Initial setting [*])	×	○
JOG data	○	×	×	×
Positioning data	○	○ (Initial setting [*])	×	○
Intelligent function module switch	×	×	○	○

* Initial setting is made to the intelligent function module parameters of the QCPU.

○: Can be set.

×: Cannot be set.

☒ POINT

- (1) Create "setting data" for each axis.
- (2) The "setting data" parameters have determined default values, and have been set to the default values before shipment from the factory. (Leave the parameters for unused axes at the default values.)
- (3) The "setting data" set in the QD72P3C3 buffer memory are not backed up. All data are initialized at power-ON of the system or reset of the programmable controller CPU.

4.1.2 Parameter setting items

The following table shows the "parameter" setting items. Set "parameters" to each axis for all controls using the QD72P3C3.

For details of each control, refer to "Chapter 8" to "Chapter 10".

For details of each setting item, refer to "Section 4.2 Parameter List".

Parameter	Control	OPR control			Positioning control			JOG operation	Related sub-function
		Near-point dog method	Stopper 3	Fast OPR control	Position control	Speed control	Current value change		
Pr.1	Software stroke limit upper limit value	-	-	-	○	○	○	○	Section 11.4
Pr.2	Software stroke limit lower limit value	-	-	-	○	○	○	○	
Pr.3	Current feed value during speed control	-	-	-	-	○	-	-	-
Pr.4	Speed limit value	◎	◎	※	◎	◎	-	◎	-
Pr.5	Bias speed at start	-	-	-	○	○	-	○	-
Pr.6	Positioning complete signal output time	○	○	※	○	○	-	-	-
Pr.7	Deviation counter clear signal output time	○	○	※	-	-	-	-	-
Pr.9	Current feed value, count value simultaneous change function selection	-	-	-	-	-	○	-	Section 12.7
Pr.10	OPR method	◎	◎	※	-	-	-	-	-
Pr.11	OPR direction	◎	◎	※	-	-	-	-	
Pr.12	OP address	◎	◎	※	-	-	-	-	
Pr.13	OPR speed	◎	◎	※	-	-	-	-	
Pr.14	Creep speed	◎	◎	※	-	-	-	-	
Pr.15	ACC/DEC time at OPR	◎	◎	※	-	-	-	-	
Pr.16	Ring counter upper limit value	-	-	-	○	-	-	-	Section 12.3
Pr.17	Positioning range upper limit value	-	-	-	○	-	-	-	
Pr.18	Coincidence detection setting	-	-	-	○	○	-	○	Section 12.5
Pr.19	Count value selection at OPR	○	○	※	-	-	-	-	Section 8.4

◎: Setting is required.

○: Make setting as necessary. (If unnecessary, the field is represented with "-".)

-: Setting not required. (This is an irrelevant item, so the set value will be ignored. If the value is the default value or within the setting range, there is no problem.)

※: Setting items of machine OPR control (near-point dog method or count 3) are used for those of fast OPR control.

■Checking the parameters

Setting ranges of to are checked when the "programmable controller CPU READY signal (Y0)" output from the programmable controller CPU to the QD72P3C3 is changed from OFF to ON. At this time, an error occurs in the parameter whose setting value is outside the range. (For details, refer to "CHAPTER 15 TROUBLESHOOTING".)

4.1.3 JOG data setting items

The "JOG data" has to be set to perform "JOG operation". The following table shows the "JOG data" setting items.

Set "JOG data" to each axis.

For details of "JOG operation" and details of each setting item, refer to "CHAPTER 10 JOG OPERATION" and "Section 4.3 JOG Data List", respectively.

JOG data	JOG operation
JOG.1 JOG speed	◎
JOG.2 JOG ACC/DEC time	◎

◎: Setting is required.

■ Checking the JOG data

Setting ranges of **JOG.1** to **JOG.2** are checked when the JOG operation starts. At this time, an error occurs in the JOG data whose setting value is outside the range. (For details, refer to "CHAPTER 15 TROUBLESHOOTING".)

4.1.4 Positioning data setting items

The "positioning data" has to be set to perform "positioning control". The following table shows the "positioning data" setting items.

One "positioning data" can be set to per axis.

For details of "positioning control" and details of each setting item, refer to "CHAPTER 9 POSITIONING CONTROL" and "Section 4.4 Positioning Data List", respectively.

Positioning data	Positioning control	Position control	Speed control	Current value change
Da.1 Operation pattern		◎	◎	◎
Da.2 Control method		◎	◎	◎
Da.3 ACC/DEC time		◎	◎	-
Da.4 Command speed		◎	◎	-
Da.5 Positioning address/movement amount		◎	-	◎

◎: Setting is required.

- : Setting not required. (This is an irrelevant item, so the set value will be ignored. If the value is the default value or within the setting range, there is no problem.)

■ Checking the positioning data

Setting ranges of **Da.1** to **Da.5** are checked when the positioning control starts. At this time, an error occurs in the positioning data whose setting value is outside the range. (For details, refer to "CHAPTER 15 TROUBLESHOOTING".)

4.1.5 Types and functions of monitor data

The monitor data area in the buffer memory stores the data showing the status of the positioning control system. To operate the positioning control system, monitor these data as necessary.

The following data are available for monitoring.

For details of monitor data, refer to "Section 4.5 Monitor Data List".

Monitor data	Monitor details
[Md.1] Current feed value	The current feed value is monitored.
[Md.2] Current speed	The current speed is monitored.
[Md.3] Count value	The count value of input pulse is stored.
[Md.4] Axis operation status	The axis operation status is monitored.
[Md.5] Axis/CH error code	The latest code of the error which occurred in the axis is monitored.
[Md.6] Axis/CH warning code	The latest code of the warning which occurred in the axis is monitored.
[Md.8] Status	The flag is monitored.
[Md.8] External I/O signal	The external I/O signal is monitored.

4.1.6 Types and functions of control data

To operate the positioning control system, perform controls as necessary. (Default value is stored to data to be used for controls at power-ON. However, the value can be set with the sequence program as necessary.)

The following items can be controlled.

For details of control data, refer to "Section 4.6 Control Data List".

Control data	Description
[Cd.1] New speed value	Set speed to be changed during operation.
[Cd.2] ACC/DEC time at speed change	Set the time until the speed reaches to the one after change from the speed before change.
[Cd.3] Speed change request	Issues a command to change speed in operation to [Cd.1] value.
[Cd.4] OPR request flag OFF request	Switches the OPR request flag from "ON to OFF".
[Cd.5] Start method	Set a control to be performed (start method).
[Cd.6] Preset value setting	Set a value to be stored in "[Md.3] Count value" by turning ON the preset command.
[Cd.7] Coincidence detection point setting	Enter a value to be compared with "[Md.3] Count value".

4.2 Parameter List

Parameter	Setting value, setting range	Factory default value	Buffer memory address for setting		
			Axis 1/CH1	Axis 2/CH2	Axis 3/CH3
Pr.1 Software stroke limit upper limit value	-1073741824 to 1073741823 (pulse)	1073741823	0 1	100 101	200 201
Pr.2 Software stroke limit lower limit value	-1073741824 to 1073741823 (pulse)	-1073741824	2 3	102 103	202 203
Pr.3 Current feed value during speed control	0: No update 1: Update	0	5	105	205
Pr.4 Speed limit value	1 to 100000 (pulse/s)* ¹	8000	6 7	106 107	206 207
Pr.5 Bias speed at start	1 to 100000 (pulse/s)* ¹	1	8 9	108 109	208 209
Pr.6 Positioning complete signal output time	0 to 65535 (ms)	300	10	110	210
Pr.7 Deviation counter clear signal output time	0: 1ms 1: 2ms 2: 10ms 3: 20ms	2	11	111	211
Pr.9 Current feed value, count value simultaneous change function selection	0: Values not changed simultaneously 1: Count value changed together at current value change 2: Current feed value changed together at preset 3: Values changed both at current value change and at preset	0	13	113	213
Pr.10 OPR method	0: OPR method 1) Near-point dog method 1: OPR method 2) Stopper 3	0	20	120	220
Pr.11 OPR direction	0: Forward direction 1: Reverse direction	0	21	121	221
Pr.12 OP address	-1073741824 to 1073741823 (pulse)	0	22 23	122 123	222 223
Pr.13 OPR speed	1 to 100000 (pulse/s)* ¹	1	24 25	124 125	224 225
Pr.14 Creep speed	1 to 100000 (pulse/s)* ¹	1	26 27	126 127	226 227
Pr.15 ACC/DEC time at OPR	1 to 5000 (ms)* ²	1000	28	128	228
Pr.16 Ring counter upper limit value	0 to 1073741823 (pulse)	0	30 31	130 131	230 231
Pr.17 Positioning range upper limit value	0 to 1073741823 (pulse)	0	32 33	132 133	232 233
Pr.18 Coincidence detection setting	0: Coincidence detection not request 1: Coincidence detection requested	0	34	134	234
Pr.19 Count value selection at OPR	0: OP address not set to count value 1: OP address set to count value	0	35	135	235

- * 1 Setting unit (pulse unit) for speed setting data changes according to the value set to "[Pr.4] Speed limit value" as the table below.

[Pr.4] Setting value of "Speed limit value" (pulse/s)	1 to 8000	8001 to 32000	32001 to 64000	64001 to 100000
Pulse unit	1-pulse unit	4-pulse unit	8-pulse unit	25-pulse unit

When setting "[Pr.4] Speed limit value" to 100000 (pulse/s) (when pulse unit is 25-pulse unit), set a value which is "multiples of 25" to speed setting parameter and data.

If setting a value that does not satisfy the condition, the value is dropped so that it can be multiples of 25. Note if setting a value under 25, corresponding to pulse unit, an error occurs.

[Setting example of speed setting parameters and data when "[Pr.4] Speed limit value" is set to 100000]

[Pr.4] Speed limit value	100000	← If Speed limit value is set to 100000 Set speed setting parameter and data so that the values can be "multiples of 25".
[Pr.5] Bias speed at start	100	
[Pr.13] OPR speed	20000	
[Pr.14] Creep speed	1000	
[Da.4] Command speed	50000	

If 65090 is set to speed setting parameter or data, it is dropped to 65075, multiples of 25.

- * 2 [Pr.15] Set ACC/DEC time at OPR within the range that the following formula is satisfied. If the condition is not satisfied, "Out of ACC/DEC time setting valid range" warning (warning code: 26) occurs, and control is performed in the time between the maximum value and the minimum value calculated by the following formula. (Refer to "Example" below.)

$$1 \leq \frac{[\text{Pr.13}] \text{ OPR speed} - [\text{Pr.14}] \text{ Creep speed}}{[\text{Pr.15}] \text{ ACC/DEC time at OPR} \times \text{Pulse unit (Refer to 1*)} \times 0.125} \leq 8000$$

[Example]

When [Pr.13] OPR speed: 8000, [Pr.14] Creep speed: 1, and [Pr.4] Speed limit value: 8000 (=1-pulse unit), the setting range of [Pr.15] ACC/DEC time at OPR is from 8 to 5000 (ms).

Pr.1 Software stroke limit upper limit value, **Pr.2** Software stroke limit lower limit value

[Setting contents]

Pr.1 : Set the upper limit for the machine movement range.

Pr.2 : Set the lower limit for the machine movement range.

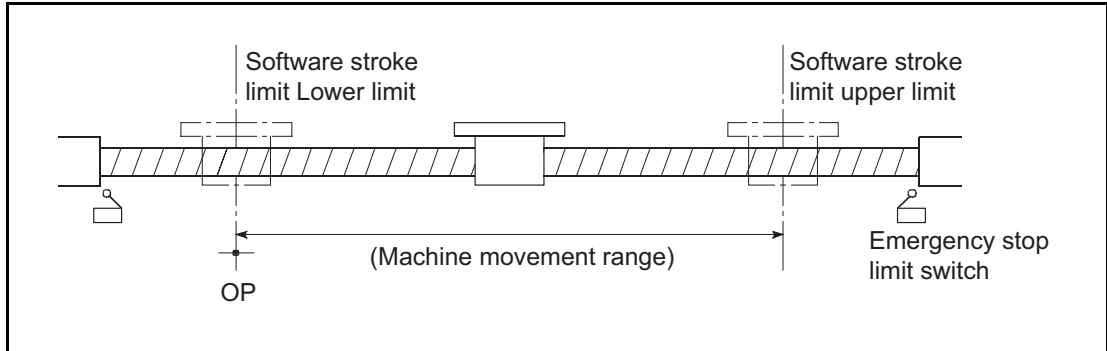

* 1 Generally, the OP is set at the lower limit or upper limit of the stroke limit.

* 2 By setting the upper limit value or lower limit value of the software stroke limit, overrun in the software can be prevented. Also an emergency stop limit switch must be attached nearby the side of outside the range.

Pr.3 Current feed value during speed control

[Setting contents]

Set whether to update "**Md.1** Current feed value" at speed control.

0: No update	The current feed value does not change. The current feed value at the start of speed control is held.
1: Update	The current feed value is updated. The current feed value at the start of speed control is updated.

Pr.4 Speed limit value

[Setting contents]

Set the maximum speed for OPR control, positioning control and JOG operation.

The Speed limit value is determined by the following two conditions.

- The number of motor rotations
- Moving speed of workpiece

Pr.5 Bias speed at start

[Setting contents]

- Set the minimum starting speed for positioning control and JOG operation.
- In case of using a motor such as a stepping motor, set this item to start the motor smoothly. (A stepping motor does not start smoothly if the motor speed is low at start.)

[Precautions]

- The minimum starting speed during
 - Set a value equal to or less than " **Pr.4** Speed limit value".
- If setting a value greater than " **Pr.4** Speed limit value", "Out of bias speed at start setting range" error (error code: 906) occurs.
- Setting unit (pulse unit) changes according to the value set to " **Pr.4** Speed limit value" as the table below.

Setting value of " Pr.4 Speed limit value" (pulse/s)	1 to 8000	8001 to 32000	32001 to 64000	64001 to 100000
Pulse unit	1-pulse unit	4-pulse unit	8-pulse unit	25-pulse unit

When setting " **Pr.4** Speed limit value" to 100000 (pulse/s) (when pulse unit is 25-pulse unit), set a value which is "multiples of 25" to " **Pr.5** Bias speed at start".

If setting a value that does not satisfy the condition, the value is dropped so that it can be multiples of 25. Note if setting a value under 25, corresponding to pulse unit, "Out of bias speed at start setting range" error (error code: 906) occurs.

POINT

If the workpiece is dragged at start, the value set to Bias speed at start may be small. In this case, set Bias speed at start using the following formula as a reference.

$$\text{Pr.5 Bias speed at start} \geq \sqrt{\text{Acceleration} \times 125 \times \text{Pulse unit}}$$

Pr.6 Positioning complete signal output time

[Setting contents]

- Set the output time of the positioning complete signal (X10 to X12) output from the QD72P3C3.
- Positioning complete designates the status when the QD72P3C3 finishes outputting pulses.
- If the setting value is 0 (ms) or the motor was stopped with the axis stop signal (Y4 to Y6) during JOG operation or speed control, the positioning complete signal (X10 to X12) are not output.

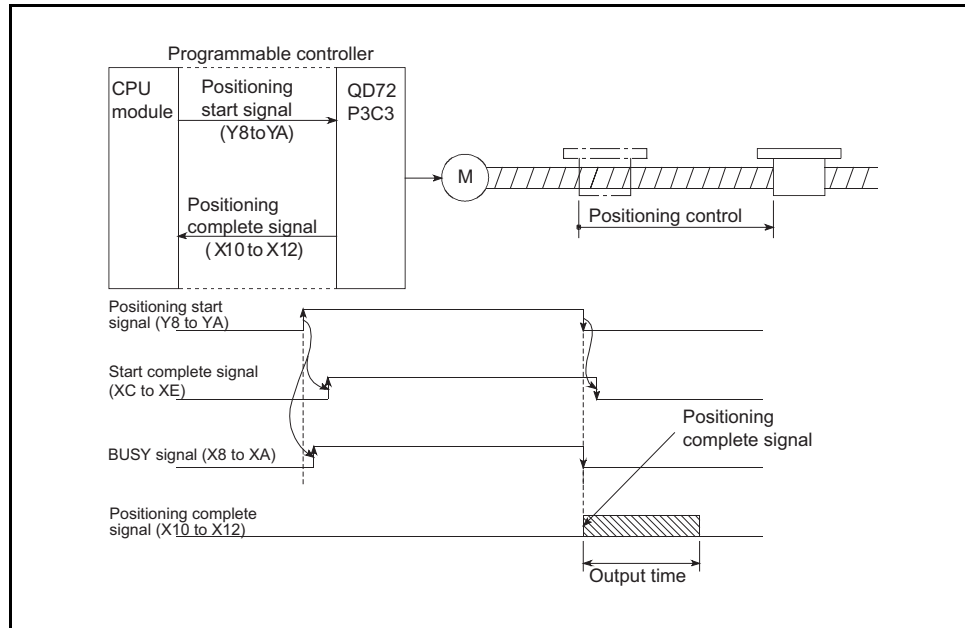

Pr.7 Deviation counter clear signal output time

[Setting contents]

Set the duration for outputting the deviation counter clear signal during machine OPR control. (For details, refer to the manual for the drive unit.)

4 DATA USED FOR POSITIONING CONTROL

Pr.9 Current feed value, count value simultaneous change function selection
 [Setting contents]

Make setting to change "Md.1 Current feed value" and "Md.3 Count value" to the same value at current value change or presetting.

0: Values not changed simultaneously	The current feed value, count value simultaneous change function is not used.
1: Count value changed together at current value change	Stores the value set to "Da.5 Positioning address/movement amount" at current value change execution to "Md.1 Current feed value" and "Md.3 Count value".
2: Current feed value changed together at preset	Stores the value set to "Cd.5 Preset value setting" at preset to "Md.1 Current feed value" and "Md.3 Count value".
3: Values changed both at current value change and at preset	Stores the values set to "Da.5 Positioning address/movement amount" at current value change execution to "Md.1 Current feed value" and "Md.3 Count value". Stores the value set to "Cd.6 Preset value setting" at preset to "Md.1 Current feed value" and "Md.3 Count value".

1 PRODUCT OUTLINE

2 SYSTEM CONFIGURATION

3 SPECIFICATIONS AND FUNCTIONS

4 DATA USED FOR POSITIONING CONTROL

5 PROCEDURES AND SETTINGS BEFORE OPERATION

6 UTILITY PACKAGE (GX Configurator-PT)

7 SEQUENCE PROGRAM USED FOR POSITIONING

8 OPR CONTROL

Pr.10 OPR method

[Setting contents]

Set "OPR method" for performing machine OPR control.

0: Near-point dog method	After the axis decelerates at the near-point dog ON, it stops at the zero signal and then the machine OPR control is completed.
1: Stopper 3	After the axis starts rotating at creep speed, it stops at the stopper and then the machine OPR control is completed at zero signal.

For details of each OPR method, refer to "Section 8.2.2 OPR method for machine OPR control".

[Machine OPR control operation]

0: Near-point dog method

(1) The machine OPR control is started.

(The axis starts movement in "Pr.11 OPR direction" at "Pr.13 OPR speed".)

(2) The near-point dog ON is detected and deceleration starts.

(3) The axis decelerates until it reaches to "Pr.14 Creep speed", and then starts moving at the Creep speed. (At this time, the near-point dog must be ON.)

(4) When the first zero signal (signal output for one pulse per one rotation) after near-point dog OFF is detected, pulse output from the QD72P3C3 stops, and the machine OPR control is completed.

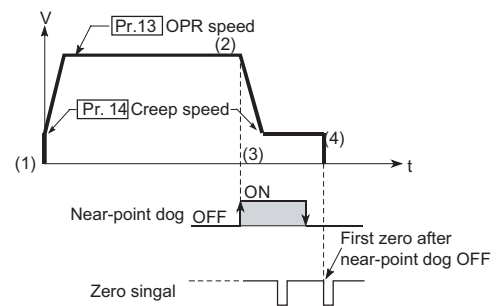

1: Stopper 3

(1)

(The axis starts movement in "Pr.11 OPR direction" at "Pr.14 Creep speed".) At this time, a torque limit to the motor is required. If torque limit is not set, the motor may be a failure at (2).)

(2) The axis contacts against the stopper at "Pr.14 Creep speed", and then stops.

(3) When the zero signal (signal which detects a contact against a stopper, and then is output) is detected, pulse output from the QD72P3C3 stops, and the machine OPR control is completed.

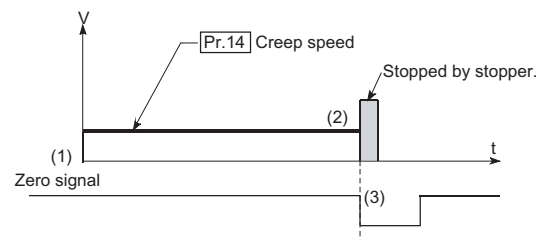

4 DATA USED FOR POSITIONING CONTROL

Pr.11 OPR direction

[Setting contents]

Set the direction to start movement when starting machine OPR control.

0: Forward direction.....Moves in the direction that the address increases. (Arrow 2))

1: Reverse direction.....Moves in the direction that the address decreases. (Arrow 1))

Normally, OP is set near the lower limit switch or the upper limit switch. Therefore, set "Pr.11 OPR direction" as shown below.

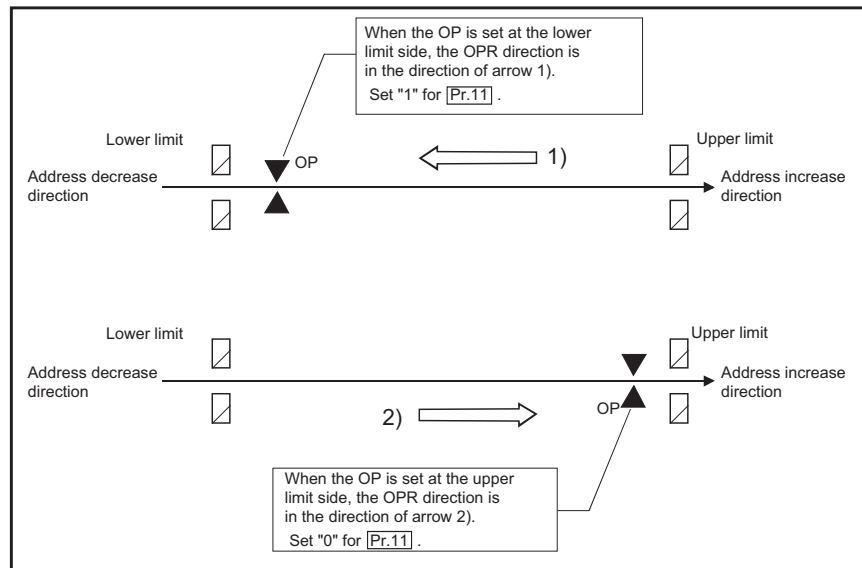

Pr.12 OP address

[Setting contents]

Set an address used as the reference point for position control (ABS system).

When machine OPR control is completed, the value of "Md.1 Current feed value" is changed to that of "Pr.12 OP address".

Pr.13 OPR speed

[Setting contents]

Set the speed for OPR control.

[Precautions]

- Set "OPR speed" to equal to or less than "Pr.4 Speed limit value". If the "Speed limit value" is exceeded, "Out of OPR speed setting range" error (error code: 913) occurs.
- Setting unit (pulse unit) for speed setting data changes according to the value set to "Pr.4 Speed limit value" as the table below.

Setting value of "Pr.4 Speed limit value" (pulse/s)	1 to 8000	8001 to 32000	32001 to 64000	64001 to 100000
Pulse unit	1-pulse unit	4-pulse unit	8-pulse unit	25-pulse unit

When setting "Pr.4 Speed limit value" to 100000 (pulse/s) (when pulse unit is 25-pulse unit), set a value which is "multiples of 25" to "Pr.13 OPR speed".

If setting a value that does not satisfy the condition, the value is dropped so that it can be multiples of 25.

Pr.14 Creep speed

[Setting contents]

- Set the creep speed (low speed immediately before stop after deceleration from OPR speed).
- The creep speed has influence to detection tolerance in OPR method with near-point dog method, and has influence to the size of impact at collision in OPR method with the stopper 3.

[Precautions]

- Set "Creep speed" to equal to or less than "**Pr.13** OPR speed". If the "OPR speed" is exceeded, "Out of creep speed setting range" error (error code: 914) occurs.

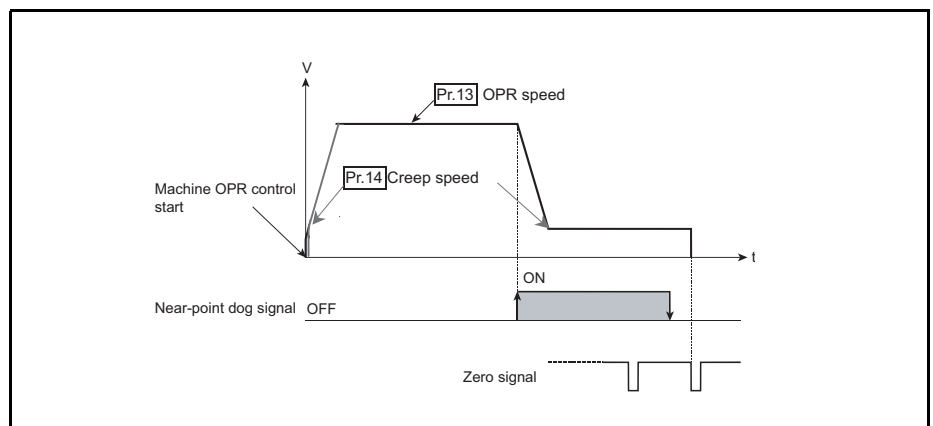

- Setting unit (pulse unit) for speed setting data changes according to the value set to "**Pr.4** Speed limit value" as the table below.

Setting value of " Pr.4 Speed limit value" (pulse/s)	1 to 8000	8001 to 32000	32001 to 64000	64001 to 100000
Pulse unit	1-pulse unit	4-pulse unit	8-pulse unit	25-pulse unit

When setting "**Pr.4** Speed limit value" to 100000 (pulse/s) (when pulse unit is 25-pulse unit), set a value which is "multiples of 25" to "**Pr.14** Creep speed". If setting a value that does not satisfy the condition, the value is dropped so that it can be multiples of 25. Note if setting a value under 25, corresponding to pulse unit, "Out of creep speed setting range" error (error code: 914) occurs.

Pr.15 ACC/DEC time at OPR

[Setting contents]

Set acceleration time from "Pr.14 Creep speed" to "Pr.13 OPR speed" and deceleration time from "Pr.13 OPR speed" to "Pr.14 Creep speed" during machine OPR control in near-point dog method.

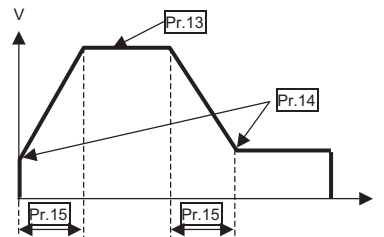

[Precautions]

Set ACC/DEC time at OPR within the range that the following formula is satisfied. If the condition is not satisfied, "Out of ACC/DEC time setting valid range" warning (warning code: 26) occurs, and control is performed in the time between the maximum value and the minimum value calculated by the following formula. (Refer to "Example" below.)

$$1 \leq \frac{\text{Pr.13 OPR speed} - \text{Pr.14 Creep speed}}{\text{Pr.15 ACC/DEC time at OPR} \times \text{Pulse unit} \times 0.125} \leq 8000$$

[Example]

When Pr.13 OPR speed: 8000, Pr.14 Creep speed: 1, and Pr.4 Speed limit value: 8000 (=1-pulse unit), the setting range of Pr.15 ACC/DEC time at OPR is from 8 to 5000 (ms).

Pr.16 Ring counter upper limit value

[Setting contents]

- Set the upper limit value of count range when the ring counter is selected for the counter format*.
 - For details of ring counter, refer to "Section 12.3 Ring Counter Function".
- * : Select the counter format using the intelligent function module switch.

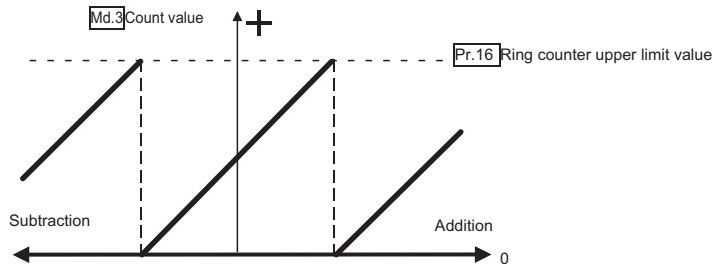

Pr.17 Positioning range upper limit value

[Setting contents]

- Set the upper limit value of positioning range when the ring counter is selected for the counter format and positioning control is performed in absolute system. When positioning control is performed at ring counter setting, the movable range in absolute system is from 0 to "**Pr.17** Positioning range upper limit value -1".

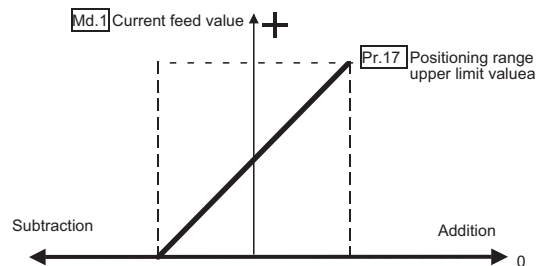

- When Speed control or JOG operation is performed at ring counter setting, "**Md.1** Current feed value" is repeatedly updated between 0 and "**Pr.17** Positioning range upper limit value -1".

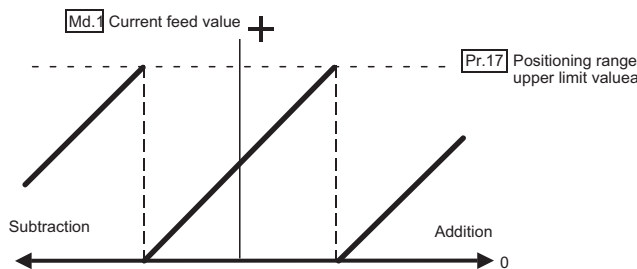

[Precautions]

- When the ring counter is selected for the counter format, the setting range of "positioning address/movement amount" is from 0 to "**Pr.17** Positioning range upper limit value -1". If trying to perform positioning control at out of this range, "Out of positioning address/movement amount setting range" error (error code: 509) occurs.
- If trying to perform positioning control when "**Md.1** Current feed value" is outside the range from 0 to "**Pr.17** Positioning range upper limit value -1", "Out of current feed value range" error (error code: 518) occurs.
- When "**Pr.17** Positioning range upper limit value" is set to 0, the setting range of "positioning address/movement amount" is from 0 to 1073741823.

Pr.18 Coincidence detection setting

[Setting contents]

Select whether to use the coincidence detection function.

0: Coincidence detection not request.....The coincidence detection function is not used.

1: Coincidence detection requested.....The coincidence detection function is used.

[Precautions]

If setting "1: Coincidence detection requested" while the ring counter function is used, "Coincidence detection function/ring counter function setting error" (error code: 925) occurs.

Pr.19 Count value selection at OPR

[Setting contents]

Select whether to set OP address to the count value when OPR is completed.

0: OP address not set to count value

Sets OP address stored into "[Md.1] Current feed value" to "[Md.3] Count value" when OPR is completed.

1: OP address set to count value

Does not set OP address stored into "[Md.1] Current feed value" to "[Md.3] Count value" when OPR is completed. (" [Md.3] Count value" does not change.)

4.3 JOG Data List

Item	Setting value, setting range	Factory default value	Buffer memory address for setting		
			Axis 1	Axis 2	Axis 3
[JOG.1] JOG speed	1 to 100000 (pulse/s)	1	40 41	140 141	240 241
[JOG.2] JOG ACC/DEC time	1 to 5000 (ms)	1000	42	142	242

[JOG.1] JOG speed

[Setting contents]

- Set the speed for JOG operation. (This value is used for both forward run JOG and reverse run JOG.)
- Set the JOG speed in the following range.

$$(\text{Pr.4 Speed limit value}) \geq (\text{JOG.1 JOG speed}) \geq (\text{Pr.5 Bias speed at start}).$$

If "JOG speed" exceeds "Speed limit value", it is limited within "Pr.4 Speed limit value".

If "JOG speed" is less than "Bias speed at start", it is limited within "Pr.5 Bias speed at start".

[Precautions]

- Setting unit (pulse unit) changes according to the value set to "Pr.4 Speed limit value" as the table below.

Setting value of "Pr.4 Speed limit value" (pulse/s)	1 to 8000	8001 to 32000	32001 to 64000	64001 to 100000
Pulse unit	1-pulse unit	4-pulse unit	8-pulse unit	25-pulse unit

When setting "Pr.4 Speed limit value" to 100000 (pulse/s) (when pulse unit is 25-pulse unit), set a value which is "multiples of 25" to "JOG.1 JOG speed".

If setting a value that does not satisfy the condition, the value is dropped so that it can be multiples of 25.

JOG.2 JOG ACC/DEC time

[Setting contents]

Set the ACC/DEC time for JOG operation.

(This ACC/DEC time is used for both forward run JOG and reverse run JOG.)

[Precautions]

Set JOG ACC/DEC time within the range that the following formula is satisfied. If the condition is not satisfied, "Out of ACC/DEC time setting valid range" warning (warning code: 26) occurs, and control is performed in the time between the maximum value and the minimum value calculated by the following formula. (Refer to "Example" below.)

$$1 \leq \frac{\text{JOG.1 JOG speed} - \text{Pr.5 Bias speed at start}}{\text{JOG.2 JOG ACC/DEC time} \times \text{Pulse unit} \times 0.125} \leq 8000$$

[Example]

When JOG.1 JOG speed: 8000, Pr.5 Bias speed at start: 1, and Pr.4 Speed limit value: 8000 (=1-pulse unit), the setting range of JOG.2 JOG ACC/DEC time is from 8 to 5000 (ms).

4.4 Positioning Data List

Item	Setting value, setting range	Factory default value	Buffer memory address for setting		
			Axis 1	Axis 2	Axis 3
Da.1 Operation pattern	0: Positioning start (independent) 5000: Positioning start (continuous)	0	90	190	290
Da.2 Control method	0: No control method 1: 1-axis linear control (ABS) 2: 1-axis linear control (INC) 3: Speed control (Forward run) 4: Speed control (Reverse run) 5: Current value change	0	91	191	291
Da.3 ACC/DEC time	1 to 5000 (ms)	1000	92	192	292
Da.4 Command speed	1 to 100000 (pulse/s)	1	94	194	294
			95	195	295
Da.5 Positioning address/movement amount	-1073741824 to 1073741823 (pulse)	0	96	196	296
			97	197	297

Da.1 Operation pattern

[Setting contents]

Area to select a start method for positioning control.

0: Positioning start (independent)

Select this item when performing positioning control whose movement amount is within 268435455pulses, regardless whether the system is the absolute system or incremental system.

5000: Positioning start (continuous)

Select this item when performing positioning control whose movement amount is over 268435455pulses, regardless whether the system is the absolute system or incremental system.

Example 1: Performing positioning control whose movement amount is within 268435455pulses

When performing position control from -99999999 (starting address) to 150000000 (end address) in absolute system, since the movement amount is 250000000pulses, select "0: Positioning start (independent)" as "**Da.1** Operation pattern".

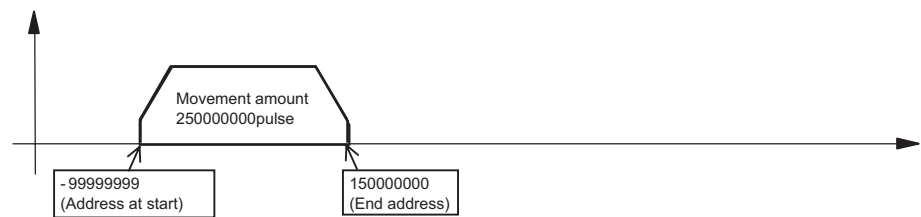

Example 2: Performing positioning control whose movement amount is over 268435455pulses

When performing position control from -99999999 (starting address) to 500000000 (end address) in absolute system

Since the movement amount is 600000000pulses, select "5000: Positioning start (continuous)" as "**Da.1** Operation pattern".

*The QD72P3C3 can output up to 268435455pulses at a time. When performing positioning control exceeding the number of pulses that can be output, perform movement in multiple times as the figure below.

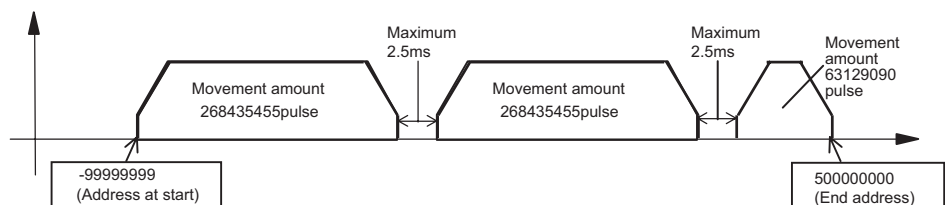

Da.2 Control method

[Setting contents]

Set the "control method" for positioning control.

- 0: No control method
- 1: 1-axis linear control (ABS)
- 2: 1-axis linear control (INC)
- 3: Speed control (Forward run)
- 4: Speed control (Reverse run)
- 5: Current value change

[Precautions]

- For details of control method, refer to "CHAPTER 9 POSITIONING CONTROL".
- If setting "0: No control method", "Out of control method setting range" error (error code: 506) occurs.

Da.3 ACC/DEC time

[Setting contents]

Set the acceleration/deceleration time for positioning control.

[Precautions]

Set ACC/DEC time within the range that the following formula is satisfied. If the condition is not satisfied, "Out of ACC/DEC time setting valid range" warning (warning code: 26) occurs, and control is performed in the time between the maximum value and the minimum value calculated by the following formula. (Refer to "Example" below.)

$$1 \leq \frac{\text{Da.4} \text{ Command speed} - \text{Pr.5} \text{ Bias speed at start}}{\text{Da.3} \text{ ACC/DEC time} \times \text{Pulse unit} \times 0.125} \leq 8000$$

[Example]

When Da.4 Command speed: 8000, Pr.5 Bias speed at start: 1, and Pr.4 Speed limit value: 8000 (=1-pulse unit), the setting range of Da.3 ACC/DEC time is from 8 to 5000 (ms).

Da.4 Command speed

[Setting contents]

Set the speed during positioning control.

[Precautions]

- If the set command speed exceeds "**Pr.4** Speed limit value", positioning control is performed at the speed limit value.
- Setting unit (pulse unit) changes according to the value set to "**Pr.4** Speed limit value" as the table below.

Pr.4 Setting value of "Speed limit value" (pulse/s)	1 to 8000	8001 to 32000	32001 to 64000	64001 to 100000
Pulse unit	1-pulse unit	4-pulse unit	8-pulse unit	25-pulse unit

When setting "**Pr.4** Speed limit value" to 100000 (pulse/s) (when pulse unit is 25-pulse unit), set a value which is "multiples of 25" to "**JOG.1** JOG speed". If setting a value that does not satisfy the condition, the value is dropped so that it can be multiples of 25.

1 PRODUCT OUTLINE

2 SYSTEM CONFIGURATION

3 SPECIFICATIONS AND FUNCTIONS

4 DATA USED FOR POSITIONING CONTROL

5 PROCEDURES AND SETTINGS BEFORE OPERATION

6 UTILITY PACKAGE (GX Configurator-PT)

7 SEQUENCE PROGRAM USED FOR POSITIONING

8 OPR CONTROL

Da.5 Positioning address/movement amount

[Setting contents]

Set an address or movement amount which is to be a set point for positioning control.

The settable range depends on "**Da.2** Control method".

(refer to (a) and (b) below.)

(a) 1-axis linear control (ABS), current value change

Set a value (positioning address) for 1-axis linear control (ABS) or current value change using the absolute address (address from the OP).

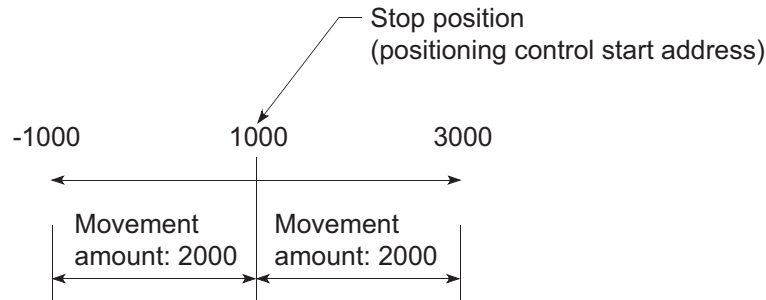

(b) 1-axis linear control (INC)

Set a signed movement amount as the setting value (movement amount) for 1-axis linear control (INC).

When the movement amount is positive: The axis moves in the positive direction (address increase direction).

When the movement amount is negative: The axis moves in the negative direction (address decrease direction).

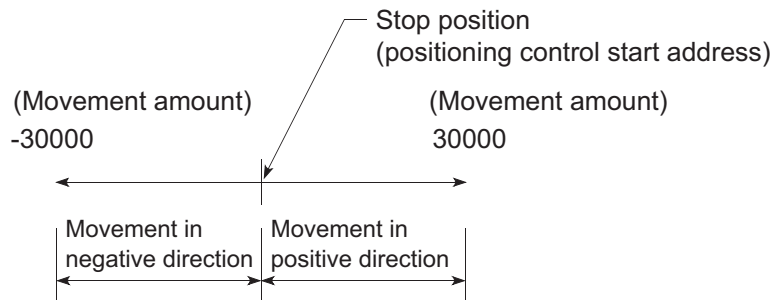

[Precautions]

If setting "0: Positioning start (independent)" to "**Da.1** Operation pattern", do not set movement amount over 268435455pulses, regardless whether the system is the absolute system or incremental system.

If set, "Out of positioning address/movement amount setting range" error (error code: 509) occurs.

4 DATA USED FOR POSITIONING CONTROL

4.5 Monitor Data List

Item	Stored data	Factory default value	Storage buffer memory address		
			Axis 1/ CH1	Axis 2/ CH2	Axis 3/ CH3
Md.1 Current feed value	<ul style="list-style-type: none"> The current position using the position when OPR is completed as the base is stored. Update timing: 2.5ms On completion of machine OPR control, the OP address is stored. Current feed value not updated/current feed value updated can be selected during speed control by parameter setting. The software stroke limit can be activated by parameter setting. If the current value has been changed by the current value change function, the new value is stored. [Range: -1073741824 to 1073741823pulses]	0	70 71	170 171	270 271
Md.2 Current speed	<ul style="list-style-type: none"> The current speed is stored. Update timing: 2.5ms [Range: 0 to 100000pulses]	0	72 73	172 173	272 273
Md.3 Count value	<ul style="list-style-type: none"> The count value of input pulse is stored. This value can be rewritten to "[Cd.6]Preset value setting" with the preset command (Y18 to Y1A). [Range: -1073741824 to 1073741823pulses]	0	74 75	174 175	274 275
Md.4 Axis operation status	The axis operation status is stored. -1: Error 0: Standby 1: Stopped 2: JOG operation 3: OPR 4: Position control 5: Speed control 6: Deceleration (axis stop ON) 7: Deceleration (JOG start OFF) 8: Fast OPR	0	76	176	276
Md.5 Axis/CH error code	<ul style="list-style-type: none"> At axis/CH error occurrence, the error code corresponding to the error description is stored. If another error occurs during axis/CH error occurrence, the latest error code is ignored. However, if an error which affects the system (error code: 800 to 830) occurs, the old error code is overwritten, and the latest error code is stored. The error codes 800 to 830 are stored into Md.5 for all axes. When the axis/CH error reset signal (Y1 to Y3) of each axis is turned ON, the error code is cleared (becomes zero). For details of error code, refer to "Section 15.2.1". 	0	77	177	277
Md.7 Axis/CH warning code	<ul style="list-style-type: none"> At axis/CH warning occurrence, the warning code corresponding to the warning description is stored. If another warning occurs during axis/CH warning occurrence, the old warning code is overwritten, and the latest warning code is stored. When the axis/CH error reset signal (Y1 to Y3) of each axis is turned ON, the warning code is cleared (becomes zero). For details of warning code, refer to "Section 15.2.2". 	0	78	178	278

1 PRODUCT OUTLINE

2 SYSTEM CONFIGURATION

3 SPECIFICATIONS AND FUNCTIONS

4 DATA USED FOR POSITIONING CONTROL

5 PROCEDURES AND SETTINGS BEFORE OPERATION

6 UTILITY PACKAGE (GX Configurator-PT)

7 SEQUENCE PROGRAM USED FOR POSITIONING

8 OPR CONTROL

Item	Stored data	Factory default value	Buffer memory address for setting		
			Axis 1/ CH1	Axis 2/ CH2	Axis 3/ CH3
Md.7 Status	<p>The ON/OFF status of the following flags are stored.</p> <p>The following items are stored.</p> <ul style="list-style-type: none"> •Speed control flag (for details, refer to "CHAPTER 9"). This flag turns ON at speed control start, and turns OFF at speed control stop. •OPR control flag (for details, refer to "CHAPTER 8"). This flag turns ON at power-ON or at machine OPR control start, and turns OFF on completion of machine OPR control. •OPR complete flag (for details, refer to "CHAPTER 8"). This flag turns ON upon normal completion of machine OPR control, and turns OFF at OPR control, positioning control or JOG operation start. •Overflow occurrence flag (for details, refer to "Section 12.1"). This flag turns ON when count value overflow occurs while linear counter is selected for the counter format. This flag turns OFF by presetting. 	0002H	79	179	279
Md.8 External I/O signal	<p>The ON/OFF status of the external I/O signals are stored.</p> <p>The following items are stored.</p> <ul style="list-style-type: none"> •Upper limit signal •Lower limit signal •Zero signal •Near-point dog signal 	0000H	80	180	280

4 DATA USED FOR POSITIONING CONTROL

4.6 Control Data List

4.6.1 Axis control data

Item	Stored data	Factory default value	Buffer memory address for setting		
			Axis 1/ CH1	Axis 2/ CH2	Axis 3/ CH3
Cd.1 New speed value	Set the new speed for JOG operation or speed control. By turning ON "Cd.3 Speed change request", the axis operates at the speed set to this buffer memory. •Set a value equal to or less than "Pr.4 Speed limit value". •Set a value equal to or more than "Pr.5 Bias speed at start". [Setting range: 1 to 100000pulse/s*1]	1	50	150	250
			51	151	251
Cd.2 ACC/DEC time at speed change	Set the time taken the current speed to shift to the speed after change. [Setting range: 1 to 5000ms*2]	1000	52	152	252
Cd.3 Speed change request	Set "1" to request speed change processing (make the value of "Cd.1 New speed value" valid) after setting "Cd.1 New speed value" for JOG operation or speed control. (This data changes automatically to "0" after speed change request acceptance.)	0	54	154	254
Cd.4 OPR request flag OFF request	When OPR request flag (b1 of Md.7) is ON, setting "1" forcibly turns this data OFF. (This data automatically changes to "0" after the OPR request flag turns OFF.)	0	55	155	255
Cd.5 Start method	Set this data when starting each control. 0: Positioning control 9000: Machine OPR control 9001: Fast OPR control	0	56	156	256
Cd.6 Preset value setting	Set a value to be set to "Md.3 Count value" with the preset command. Turning ON the preset command (Y18 to Y1A) stores the value set to this buffer memory into "Md.3 Count value". [Setting range: -1073741824 to 1073741823]	0	60	160	260
			61	161	261
Cd.7 Coincidence detection point setting	Enter a value to be compared with "Md.3 Count value". Setting "1" to "Pr.18 Coincidence detection setting" performs coincidence detection. [Setting range: -1073741824 to 1073741823]	0	62	162	262
			63	163	263

1 PRODUCT OUTLINE

2 SYSTEM CONFIGURATION

3 SPECIFICATIONS AND FUNCTIONS

4 DATA USED FOR POSITIONING CONTROL

5 PROCEDURES AND SETTINGS BEFORE OPERATION

6 UTILITY PACKAGE (GX Configurator-PT)

7 SEQUENCE PROGRAM USED FOR POSITIONING

8 OPR CONTROL

* 1: Setting unit (pulse unit) changes according to the value set to "[Pr.4] Speed limit value" as the table below.

Setting value of "[Pr.4] Speed limit value" (pulse/s)	1 to 8000	8001 to 32000	32001 to 64000	64001 to 100000
Pulse unit	1-pulse unit	4-pulse unit	8-pulse unit	25-pulse unit

When setting "[Pr.4] Speed limit value" to 100000 (pulse/s) (when pulse unit is 25-pulse unit), set a value which is "multiples of 25" to "[Cd.1] Speed change value".

If setting a value that does not satisfy the condition, the value is dropped so that it can be multiples of 25.

* 2: Set [Cd.2] ACC/DEC time at speed change within the range that the following formula is satisfied. If the condition is not satisfied, "Out of ACC/DEC time setting valid range" warning (warning code: 26) occurs, and control is performed in the time between the maximum value and the minimum value calculated by the following formula. (Refer to "Example" below.)

$$1 \leq \frac{[Cd.1] \text{ New speed value} - [Pr.5] \text{ Bias speed at start}}{[Cd.2] \text{ ACC/DEC time at speed change} \times \text{Pulse unit} \times 0.125} \leq 8000$$

[Example]

When [Cd.1] Speed change value: 8000, [Pr.14] Creep speed: 1, and Speed limit value: 8000 (=1-pulse unit), the setting range of [Cd.2] ACC/DEC time at speed change is from 8 to 5000 (ms).

CHAPTER 5 PROCEDURES AND SETTINGS BEFORE OPERATION

This chapter describes the operating procedures before operation, part names, and setting and wiring method of the QD72P3C3.

5.1 Handling Precautions

This section describes precautions on handling the QD72P3C3.

WARNING

- Be sure to shut off all phases of the external power supply used by the system before cleaning or retightening module fixing screw.
Failure to do so may cause an electric shock.

CAUTION

- Use the programmable controller in the environment conditions given in the general specifications of the User's Manual for the CPU module.
Failure to do so may cause an electric shock, fire, malfunction, or damage to or deterioration of the product.
- Do not directly touch any conductive part or electronic part of the module.
Doing so may cause a malfunction or failure of the module.
- Be careful to prevent foreign matter such as dust or wire chips from entering the module.
Failure to do so may cause a fire, failure or malfunction.
- Do not disassemble or remodel each of the modules.
Doing so may cause failure, malfunctions, personal injuries and/or a fire.
- Be sure to shut off all phases of the external power supply used by the system before mounting or removing the module.
Not doing so may result in a failure or malfunction of the module.
- While pressing the installation lever located at the bottom of the module, fully insert the module fixing projection into the fixing hole in the base unit and press the module using the hole as a fulcrum.
Incorrect module mounting may cause a malfunction, failure, or drop of the module.
In an environment of frequent vibrations, secure the module with screws.
The screws must be tightened within the specified torque range.
If the screw is too loose, it may cause a drop, short circuit, or malfunction.
Excessive tightening may damage the screw and/or the module, resulting in a drop, short circuit or malfunction.

(1) Main body

- The module case is made of resin. Do not drop nor apply strong impact onto the case.
- Do not remove the printed-circuit board of the QD72P3C3 from the case. Doing so may cause a failure.
- Tighten the module fixing screws within the following range.

Screw	Tightening torque range
Module fixing screw (M3 screw) ^{*1}	0.36 to 0.48N · m

* 1 The module can be easily fixed to the base unit using a hook located on the top of the module. However, it is recommended to secure the module with module fixing screws if the module is subject to frequent vibrations.

(2) Cable

- Do not press on the cable with a sharp object.
- Do not twist the cable with force.
- Do not forcibly pull the cable.
- Do not step on the cable.
- Do not place objects on the cable.
- Do not damage the cable coatings.

(3) Installation environment

Do not install the module in the following environment:

- Where the ambient temperature exceeds the 0 to 55°C range
- Where the ambient humidity exceeds the 5 to 95% RH range
- Where condensation occurs due to sudden temperature change
- Where corrosive gas or flammable gas exists
- Where high levels of dust, conductive powder such as iron chips, oil mist, salt or organic solvent exists
- Where the module is subjected to direct sunlight
- Where intense electric fields or magnetic fields are created
- Where vibration or impact could be directly applied onto the main body

5.2 Procedures Before Operation

The following flowchart shows the procedures for operating the QD72P3C3.

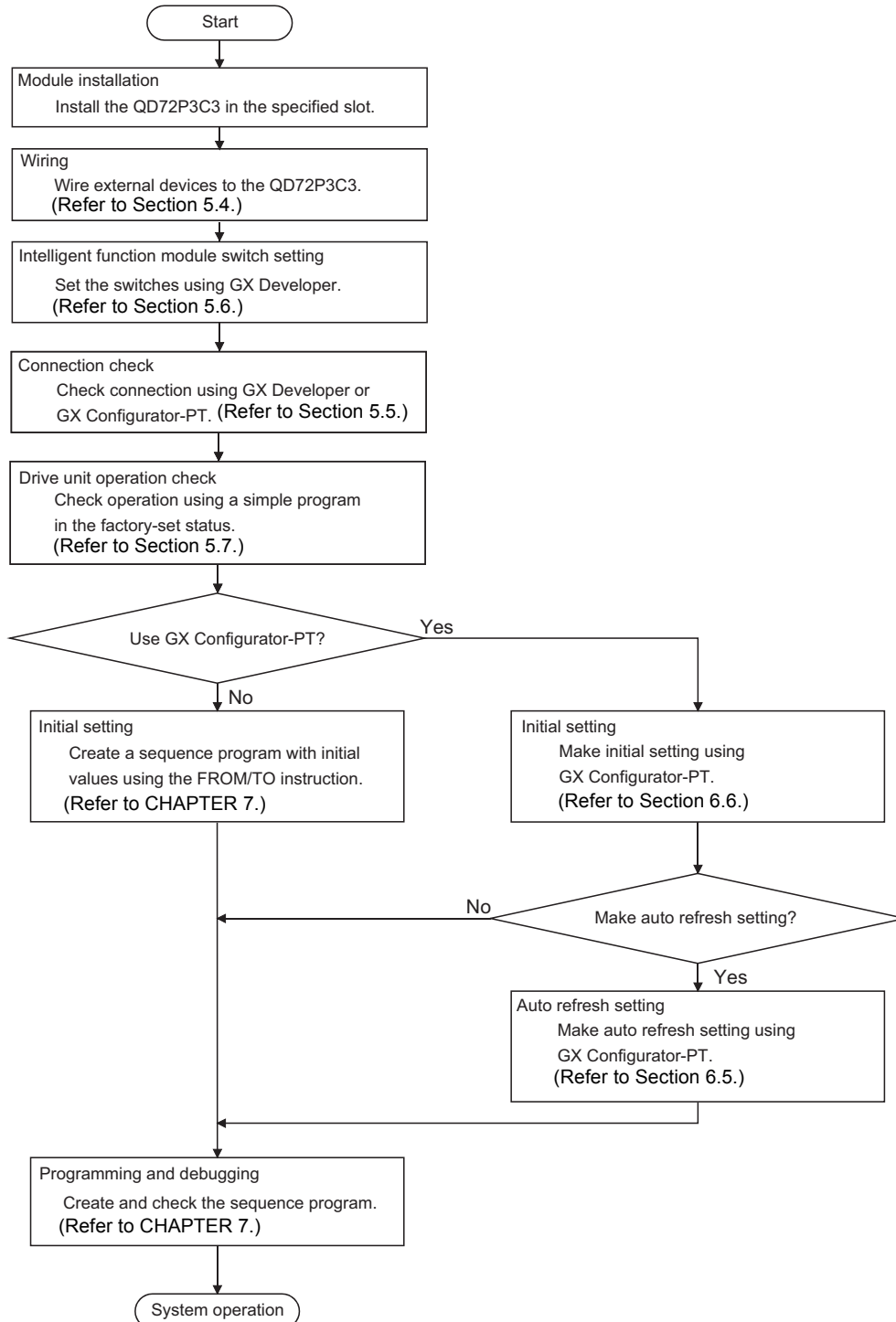

5.3 Part Names

(1) The following explains the part names of the QD72P3C3.

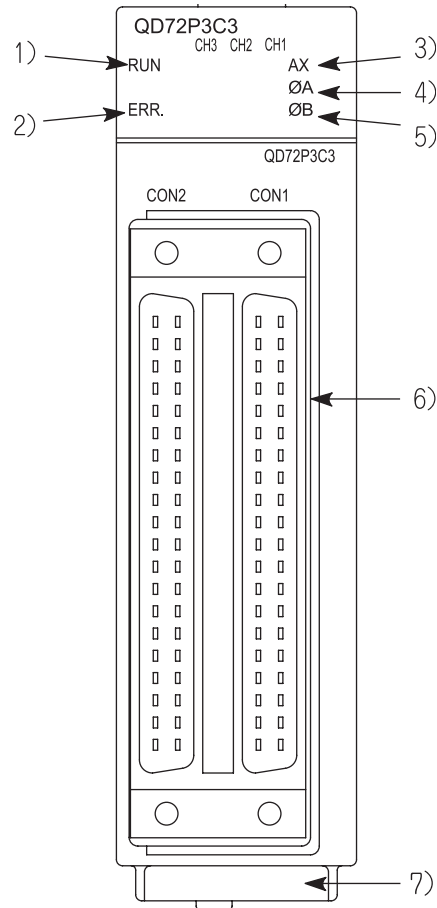

No.	Name	Description
1)	RUN LED	Refer to the next page.
2)	ERR. LED	
3)	AX LED	
4)	φA LED	
5)	φB LED	
6)	External device connector	Connector for connecting a drive unit, encoder, and mechanical system inputs
7)	Serial number plate	Indicates the serial No. of the QD72P3C3.

(2) The LED display changes according to the operation status of the QD72P3C3 and Axis/CH as follows.

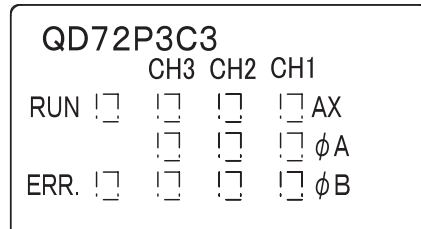

Display contents	Operation status	Description	Display contents	Operation status	Description
RUN <input type="checkbox"/> CH3 <input type="checkbox"/> CH2 <input type="checkbox"/> CH1 <input type="checkbox"/> AX ERR. <input type="checkbox"/> <input type="checkbox"/> <input type="checkbox"/> <input type="checkbox"/> ϕ A <input type="checkbox"/> <input type="checkbox"/> <input type="checkbox"/> <input type="checkbox"/> ϕ B	•RUN LED is OFF. (The status of ERR. LED, AX1 to AX3 are undefined.)	Hardware: Failure Module: Error	RUN <input checked="" type="checkbox"/> CH3 <input type="checkbox"/> CH2 <input type="checkbox"/> CH1 <input checked="" type="checkbox"/> AX ERR. <input type="checkbox"/> <input type="checkbox"/> <input type="checkbox"/> <input type="checkbox"/> ϕ A <input type="checkbox"/> <input type="checkbox"/> <input type="checkbox"/> <input type="checkbox"/> ϕ B	•AX_CH1 LED is ON. (Same for other axes.)	Axis: In operation
RUN <input checked="" type="checkbox"/> CH3 <input type="checkbox"/> CH2 <input type="checkbox"/> CH1 <input type="checkbox"/> AX ERR. <input type="checkbox"/> <input type="checkbox"/> <input type="checkbox"/> <input type="checkbox"/> ϕ A <input type="checkbox"/> <input type="checkbox"/> <input type="checkbox"/> <input type="checkbox"/> ϕ B	•RUN LED is ON. •ERR. LED is OFF.	Module: Normal	RUN <input checked="" type="checkbox"/> CH3 <input type="checkbox"/> CH2 <input type="checkbox"/> CH1 <input checked="" type="checkbox"/> AX ERR. <input checked="" type="checkbox"/> <input type="checkbox"/> <input type="checkbox"/> <input type="checkbox"/> ϕ A <input type="checkbox"/> <input type="checkbox"/> <input type="checkbox"/> <input type="checkbox"/> ϕ B	•AX_CH1 LED is flashing. (Same for other axes.) •ERR. LED is flashing.	Axis/CH: Error
RUN <input checked="" type="checkbox"/> CH3 <input type="checkbox"/> CH2 <input type="checkbox"/> CH1 <input type="checkbox"/> AX ERR. <input checked="" type="checkbox"/> <input type="checkbox"/> <input type="checkbox"/> <input type="checkbox"/> ϕ A <input type="checkbox"/> <input type="checkbox"/> <input type="checkbox"/> <input type="checkbox"/> ϕ B	•RUN LED is ON. ERR. LED is ON.	System: Error	RUN <input checked="" type="checkbox"/> CH3 <input type="checkbox"/> CH2 <input type="checkbox"/> CH1 <input type="checkbox"/> AX ERR. <input type="checkbox"/> <input type="checkbox"/> <input type="checkbox"/> <input type="checkbox"/> <input checked="" type="checkbox"/> ϕ A <input type="checkbox"/> <input type="checkbox"/> <input type="checkbox"/> <input type="checkbox"/> ϕ B	• ϕ A_CH1 LED is ON. (Same for other CHs.)	Phase A voltage: Applying
RUN <input checked="" type="checkbox"/> CH3 <input type="checkbox"/> CH2 <input type="checkbox"/> CH1 <input type="checkbox"/> AX ERR. <input type="checkbox"/> <input type="checkbox"/> <input type="checkbox"/> <input type="checkbox"/> ϕ A <input type="checkbox"/> <input type="checkbox"/> <input type="checkbox"/> <input type="checkbox"/> ϕ B	•AX_CH1 to AX_CH3 LEDs are OFF.	Axes: Stopped Axes: Standby	RUN <input checked="" type="checkbox"/> CH3 <input type="checkbox"/> CH2 <input type="checkbox"/> CH1 <input type="checkbox"/> AX ERR. <input type="checkbox"/> <input type="checkbox"/> <input type="checkbox"/> <input type="checkbox"/> ϕ A <input type="checkbox"/> <input type="checkbox"/> <input type="checkbox"/> <input type="checkbox"/> <input checked="" type="checkbox"/> ϕ B	• ϕ B_CH1 LED is ON. (Same for other CHs.)	Phase B voltage: Applying

Symbols in the Display contents columns indicate the following status:

: OFF, : ON, : Flashing

■ External device connector

Purchase the connector for the QD72P3C3 separately.

The following tables show the recommended connector types and crimp tool.

(a) Connector types

Type	Model
Soldering type, straight out	A6CON1
Crimp type, straight out	A6CON2
Soldering type, usable for both straight out and diagonal out	A6CON4

(b) Connector crimp tool

Type	Model	Applicable wire size	Contact
Crimp tool	FCN-363T-T005/H	AWG24	FUJITSU COMPONENT LIMITED

5.4 Wiring

This section describes how to wire a drive unit and mechanical system inputs to the QD72P3C3.

The following describes the precautions for wiring the QD72P3C3. Read these precautions together with "Section 5.1 Handling Precautions" to ensure work safety.

5.4.1 Wiring precautions

- (1) **Correctly wire cables to the QD72P3C3 after checking the terminal layout.**
(For details of terminal layout, refer to "Section 3.5.2 Signal layout for external device connector".)
- (2) **Correctly solder or bond the external device connector (A6CON1/A6CON2/A6CON4). An incomplete soldering or bonding may cause a malfunction.**
- (3) **Be careful to prevent foreign matter such as dust or wire chips from entering the QD72P3C3. Failure to do so may cause a fire, failure or malfunction.**
- (4) **A protective film is attached to the top of the QD72P3C3 to prevent foreign matter such as wire chips from entering the module during wiring. Do not remove the film during wiring. Be sure to remove it for heat dissipation before system operation.**
- (5) **Securely mount the external device connector (A6CON1/A6CON2/A6CON4) to the connector on the QD72P3C3 with two screws.**
- (6) **When disconnecting the cable connected to the QD72P3C3 or drive unit, do not pull it by holding the cable part. Hold the connector connected to the QD72P3C3 or drive unit and disconnect it. Pulling the cable part with the cable still connected to the QD72P3C3 or drive unit may cause a malfunction. Doing so may also cause damage of the QD72P3C3, drive unit or cable.**
- (7) **Do not bind together or locate close to each other the QD72P3C3 cables connecting to external I/O signals or drive unit with the main circuit line, power line, and load lines other than for the programmable controller. Keep a distance of 100mm (3.94inch) or more between those cables and lines. Failure to do so may cause a malfunction due to noise, surge, or induction.**

- (8) When the QD72P3C3 connection cable is located close to the power line (less than 100mm (3.94inch)), use a shielded cable for noise suppression. Be sure to ground the shield of shielded cables to a control panel on the QD72P3C3 side. (A wiring example is shown on the next page.)

[Wiring example of shielded cables]

Wiring example for noise suppression using the A6CON1

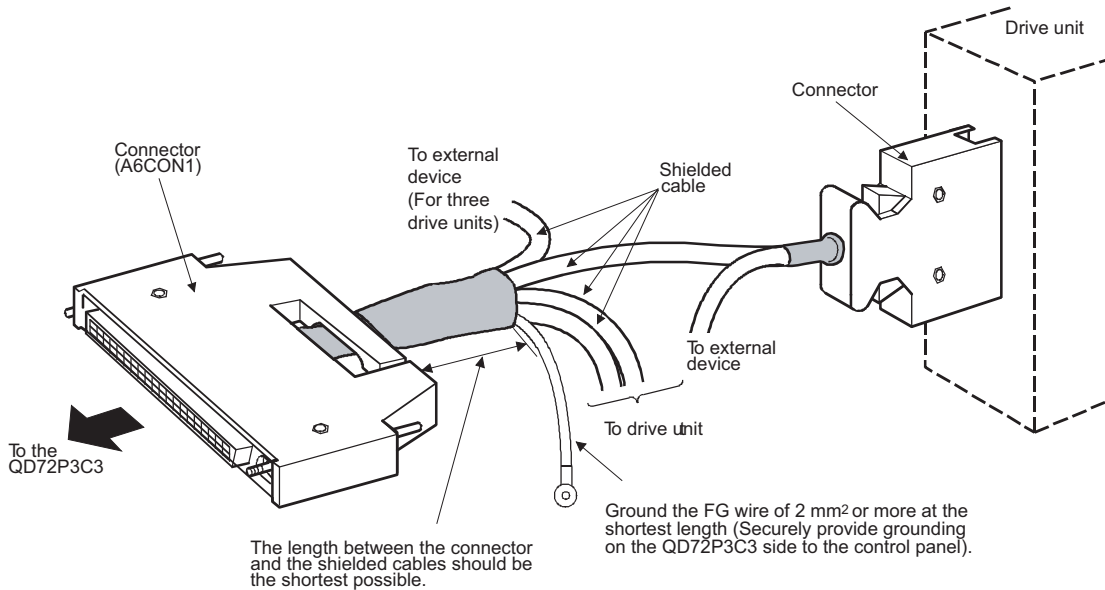

[Processing example of shielded cables]

Connecting FG wire and shielded cables

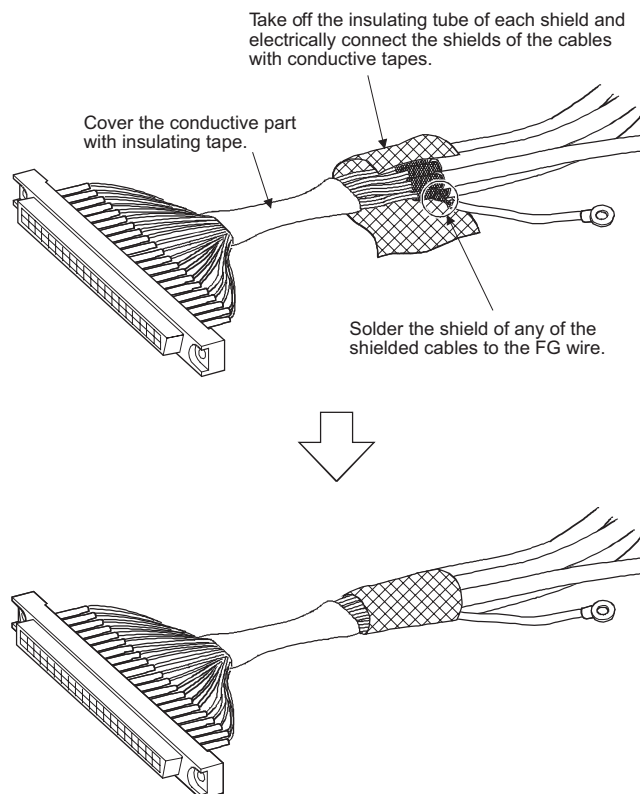

Connector (A6CON1) assembly

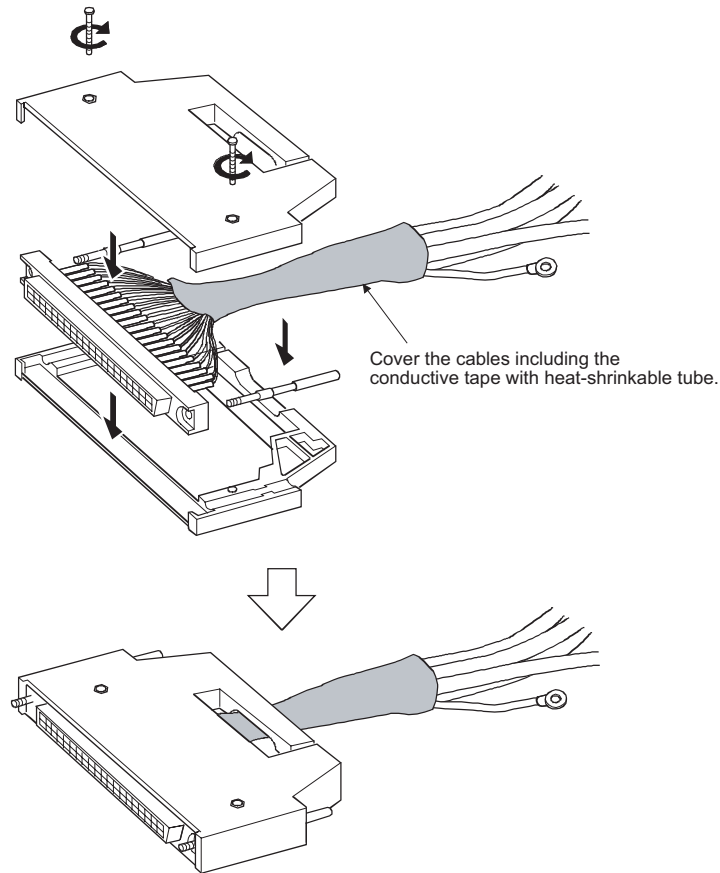

- (9) Be sure to place the cables connected to the QD72P3C3 in a duct or clamp them. Failure to do so may cause not only damage to the QD72P3C3, drive unit and/or cables by pulling unfixed cables carelessly, but also a malfunction due to poor cable connection.
- (10) To conform the wiring to the EMC and Low Voltage Directives, ground the shielded cables to a control panel using the AD75CK cable clamp (manufactured by Mitsubishi Electric Corporation).

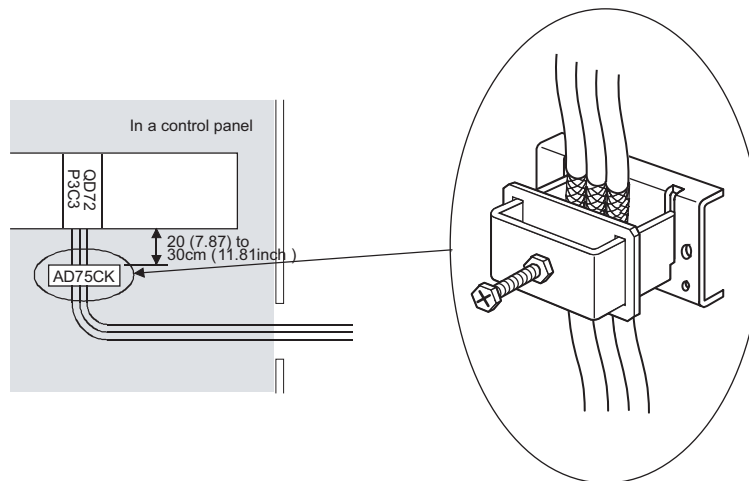

For details of the AD75CK, refer to the following.

☞ AD75CK-type Cable Clamping Instruction Manual

[Wiring examples using duct (improper example and improved example)]

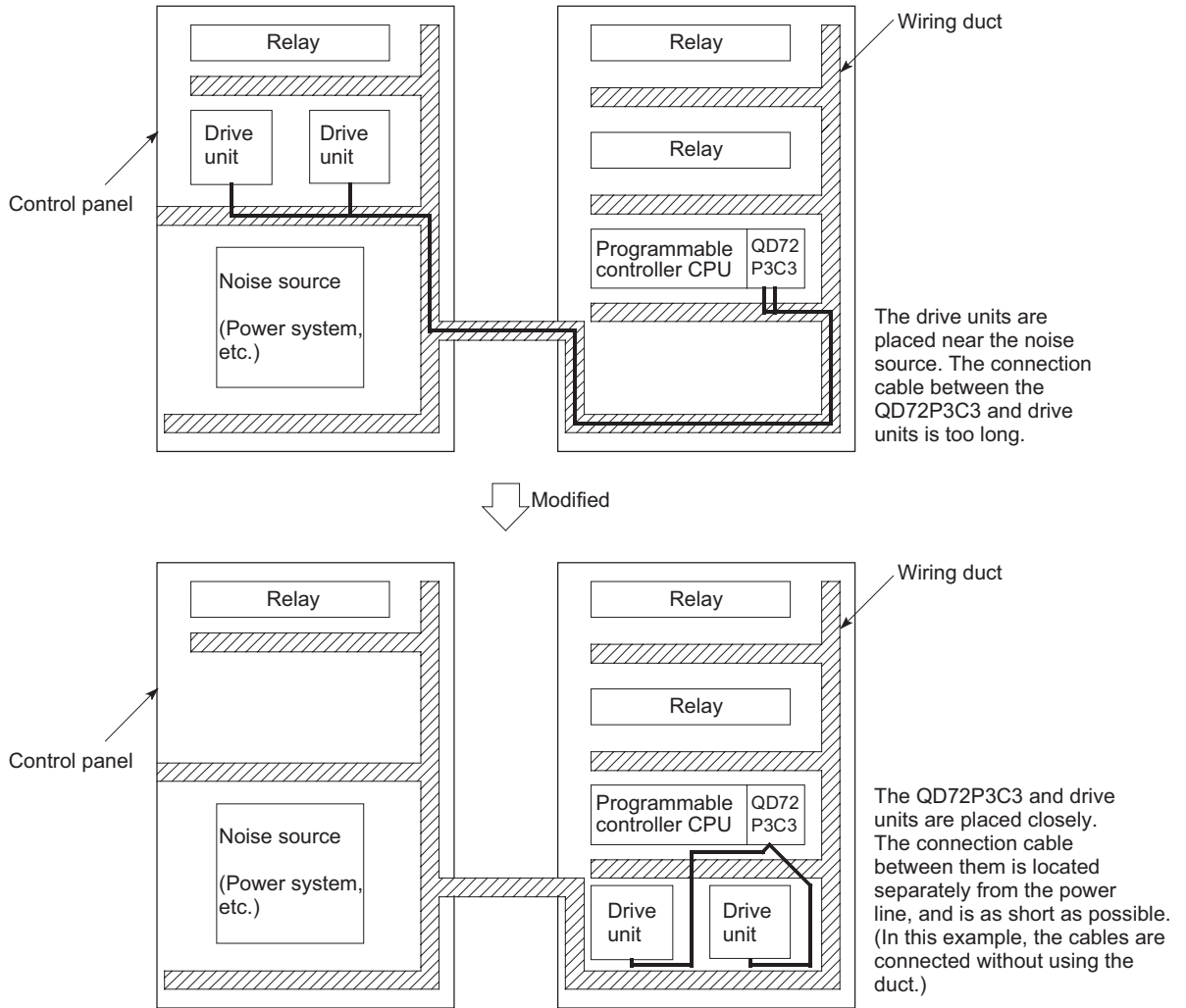

5.5 Wiring Check

5.5.1 Check items at wiring completion

Check the following items after installation and wiring of the QD72P3C3 are completed.

- Is the module correctly wired?....."Connection check"

By performing "connection check", "whether the QD72P3C3 recognizes the external I/O signals, such as near-point dog signal and upper/lower limit signals" can be checked.

The following describes the method of "connection check".

(1) Checking using GX Developer

Read the monitor data "[Md.8] External I/O signal" using the monitor function (Buffer memory batch) and check the read values.

Signal name	Buffer memory address		
	Axis 1	Axis 2	Axis 3
[Md.8] External I/O signal	80	180	280

[Bit pattern]

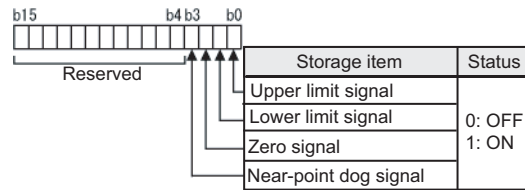

(Example) Checking the external I/O signals of Axis 1 (GX Developer screen)

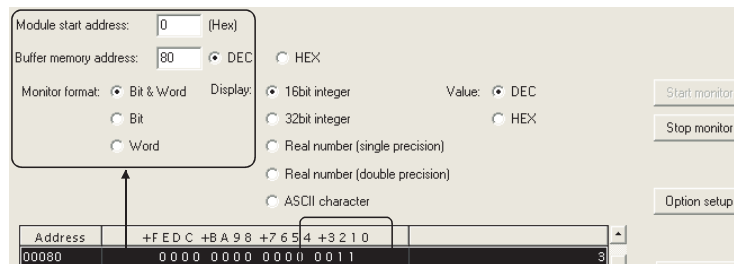

Set the [Buffer memory address] of "[Md.8] External I/O signal" of Axis 1 in decimal.

- b0 (Upper limit signal ON)
- b1 (Lower limit signal ON)
- b2 (Zero signal OFF)
- b3 (Near-point dog signal OFF)

The external I/O signal status can also be checked on the [System monitor] screen. For details, refer to "Section 13.3 External I/O Signal Monitor Function".

(2) Checking using GX Configurator-PT

Monitor the external I/O signal status on the [Monitor/Test] screen.
(For details, refer to "Section 6.6 Monitor/Test".)

(Example) Checking the external I/O signals of Axis 1 (Axis #1 OPR Monitor)
(GX Configurator-PT screen)

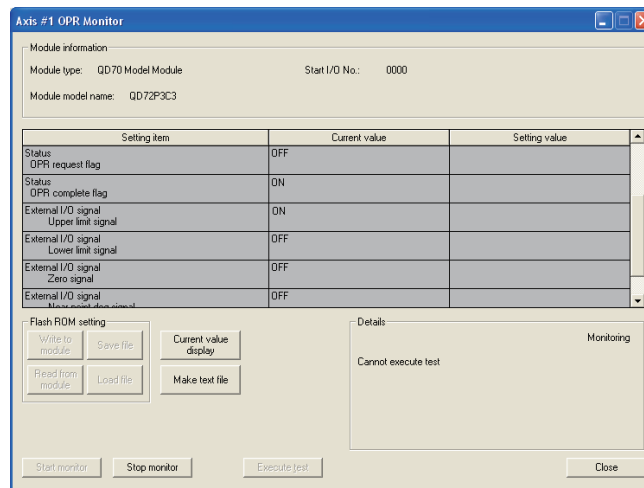

⚠ IMPORTANT

If the QD72P3C3 has a failure or does not recognize necessary signals, such as the near-point dog signal and upper/lower limit signals, an unexpected accident, e.g. "the axis collides with the stopper without decelerating at the near-point dog during machine OPR control", may occur.

Be sure to perform "connection check" not only when the positioning control system is configured but also when any modification, such as module change or rewiring, has been made.

5.6 Intelligent Function Module Switch Setting

Pulse I/O mode, external I/O signal logic, and counter format can be set to the QD72P3C3 with intelligent function module switch setting of GX Developer.

The switch setting is made on the [I/O assignment] tab in the [PLC Parameter] screen of GX Developer.

The switch has five switches and is set at 16-bit data.

The switch settings become effective after power-ON or the programmable controller CPU reset. The settings cannot be changed during operation.

(1) Setting item

Switch No.	Setting item	Setting contents/bit assignment	Factory default value																				
Switch 1	Pulse output mode (For details, refer to (1)(a) in this section.)	<table border="1" style="width: 100%; text-align: center;"> <tr> <td>b15</td><td>b14</td><td>b12</td><td>b11</td><td>b9</td><td>b8</td><td>b7</td><td>b6</td><td>b4</td><td>b3</td><td>b2</td><td>b0</td> </tr> <tr> <td>-</td><td>Zero signal input logic selection</td><td>-</td><td>Deviation counter clear output logic selection</td><td>-</td><td>Pulse output logic selection</td><td>-</td><td>Pulse output mode</td> </tr> </table>	b15	b14	b12	b11	b9	b8	b7	b6	b4	b3	b2	b0	-	Zero signal input logic selection	-	Deviation counter clear output logic selection	-	Pulse output logic selection	-	Pulse output mode	0000H
	b15	b14	b12	b11	b9	b8	b7	b6	b4	b3	b2	b0											
	-	Zero signal input logic selection	-	Deviation counter clear output logic selection	-	Pulse output logic selection	-	Pulse output mode															
	Pulse output logic selection	Pulse output mode (b2: Axis No.3, b1: Axis No.2, b0: Axis No.1) 0 : CW/CCW mode 1 : PULSE/SIGN mode Pulse output logic selection (b6: Axis No.3, b5: Axis No.2, b4: Axis No.1) 0 : Negative logic 1 : Positive logic																					
Deviation counter clear output logic selection	Deviation counter clear output logic selection (b10: Axis No.3, b9: Axis No.2, b8: Axis No.1) 0 : Negative logic 1 : Positive logic																						
Zero signal input logic selection	Zero signal input logic selection (b14: Axis No.3, b13: Axis No.2, b12: Axis No.1) 0 : Negative logic 1 : Positive logic																						
Switch 2	Near-point dog signal input logic selection	<table border="1" style="width: 100%; text-align: center;"> <tr> <td>b15</td><td>b11</td><td>b9</td><td>b8</td><td>b7</td><td>b6</td><td>b4</td><td>b3</td><td>b2</td><td>b0</td> </tr> <tr> <td>-</td><td>Upper limit signal input logic selection</td><td>-</td><td>Lower limit signal input logic selection</td><td>-</td><td>Near-point dog signal input logic selection</td> </tr> </table>	b15	b11	b9	b8	b7	b6	b4	b3	b2	b0	-	Upper limit signal input logic selection	-	Lower limit signal input logic selection	-	Near-point dog signal input logic selection	0000H				
	b15	b11	b9	b8	b7	b6	b4	b3	b2	b0													
	-	Upper limit signal input logic selection	-	Lower limit signal input logic selection	-	Near-point dog signal input logic selection																	
Lower limit signal input logic selection	Near-point dog signal input logic selection (b2: Axis No.3, b1: Axis No.2, b0: Axis No.1) 0 : Negative logic 1 : Positive logic Lower limit signal input logic selection (b6: Axis No.3, b5: Axis No.2, b4: Axis No.1) 0 : Negative logic 1 : Positive logic																						
Upper limit signal input logic selection	Upper limit signal input logic selection (b10: Axis No.3, b9: Axis No.2, b8: Axis No.1) 0 : Negative logic 1 : Positive logic																						
Switch 3	Pulse input mode (For details, refer to (1)(b) in this section.)	<table border="1" style="width: 100%; text-align: center;"> <tr> <td>b15</td><td>b11</td><td>b10</td><td>b8</td><td>b7</td><td>b6</td><td>b5</td><td>b0</td> </tr> <tr> <td>-</td><td>Counter format</td><td>-</td><td>Pulse input mode</td> </tr> </table>	b15	b11	b10	b8	b7	b6	b5	b0	-	Counter format	-	Pulse input mode	0000H								
	b15	b11	b10	b8	b7	b6	b5	b0															
-	Counter format	-	Pulse input mode																				
Counter format*	Pulse input mode (b5 to 4: CH3, b3 to 2: CH2, b1 to 0: CH1) 00 : CW/CCW 01 : 1 multiple of 2 phases 10 : 2 multiples of 2 phases 11 : 4 multiples of 2 phases Counter format (b10: CH3, b9: CH2, b8: CH1) 0 : Linear counter 1 : Ring counter																						
Switch 4	Reserved																						
Switch 5	Reserved																						

* When ring counter is set for the counter format, the positioning control range is 0 to 1073741823 (pulse).

[Setting example]

Setting item	Setting contents			Target signal name	Switch setting
	Axis 3	Axis 2	Axis 1		
Pulse output mode	PULSE/SIGN mode		CW/CCW mode	PULSE F□, PULSE R□	Switch 1 :6126H
Pulse output logic selection	N	P	N		
Deviation counter clear output logic selection	N	N	P	CLEAR□	
Zero signal input logic selection	P	P	N	PG0□	
Near-point dog signal input logic selection	P	N	P	DOG□	Switch 2 :0005H
Lower limit signal input logic selection	N	N	N	RLS□	
Upper limit signal input logic selection	N	N	N	FLS□	
Pulse input mode	2 multiples of 2 phases	CW/CCW		CH□ A, CH□ B	Switch 3 :0420H
Counter format	Ring counter	Linear counter			

P: positive logic, N: negative logic

* Axis/channel No. is displayed in the □.

(a) Pulse output mode

Sets the pulse output mode applicable to the drive unit used.

For switching between positive and negative logic of the pulse, "Switch 1" is used. The following shows the examples of each pulse output mode.

1) CW/CCW mode

During forward run, the forward run feed pulse (CW) is output.

During reverse run, the reverse run feed pulse (CCW) is output.

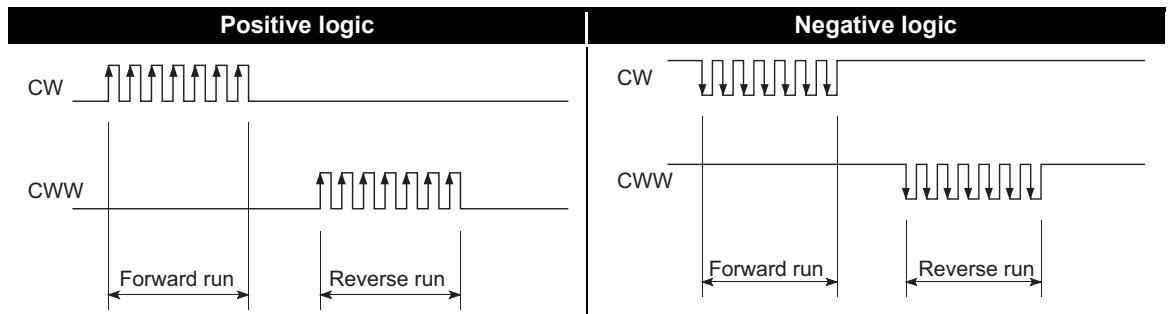

* CW is output from the "PULSE F" external I/O signal and CCW from "PULSE R". (Refer to "Section 3.5.3".)

2) PULSE/SIGN mode

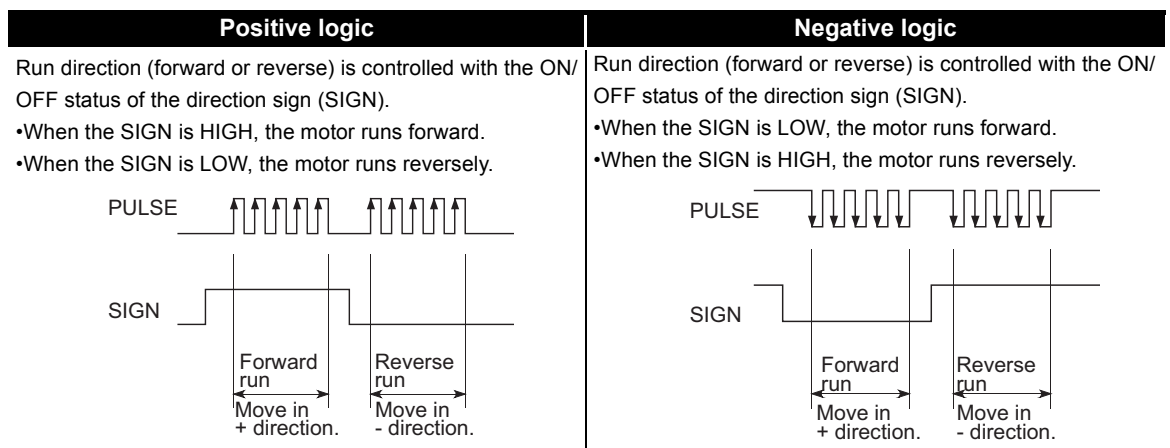

* PULSE is output from the "PULSE F" external I/O signal and SIGN from "PULSE R". (Refer to "Section 3.5.3".)

(b) Pulse input mode

Sets the pulse input mode applicable to the encoder and pulse generator used.

The following shows the examples of each pulse input mode.

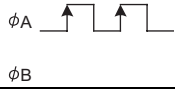
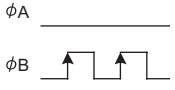
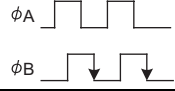
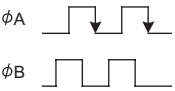
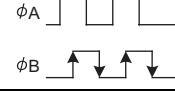
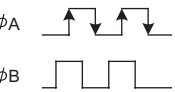
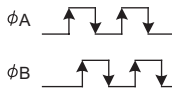
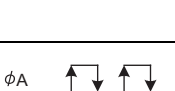
Pulse input mode	Count timing		
CW/CCW	For addition count		Counts on the rising edge (↑) of ϕA .
	For subtraction count		Counts on the rising edge (↑) of ϕB .
1 multiple of 2 phases ^{*2}	For addition count		When ϕA is OFF, counts on the falling edge (↓) of ϕB .
	For subtraction count		When ϕB is OFF, counts on the falling edge (↓) of ϕA .
2 multiples of 2 phases ^{*2}	For addition count		When ϕA is ON, counts on the rising edge (↑) of ϕB . When ϕA is OFF, counts on the falling edge (↓) of ϕB .
	For subtraction count		When ϕB is ON, counts on the rising edge (↑) of ϕA . When ϕB is OFF, counts on the falling edge (↓) of ϕA .
4 multiples of 2 phases	For addition count		When ϕB is OFF, counts on the rising edge (↑) of ϕA . When ϕB is ON, counts on the falling edge (↓) of ϕA . When ϕA is ON, counts on the rising edge (↑) of ϕB . When ϕA is OFF, counts on the falling edge (↓) of ϕB .
	For subtraction count		When ϕB is ON, counts on the rising edge (↑) of ϕA . When ϕB is OFF, counts on the falling edge (↓) of ϕA . When ϕA is OFF, counts on the rising edge (↑) of ϕB . When ϕA is ON, counts on the falling edge (↓) of ϕB .

❗ IMPORTANT

- *1: The module may not be able to operate normally if each I/O signal logic is set incorrectly. Pay special attention when changing the setting from the default value.
- *2: When using the input mode of either 1 multiple of 2 phases or 2 multiples of 2 phases, be sure to input 2-phase pulses. With these input methods, pulses are counted according to the changes between phase A and phase B.

(2) Operating procedure

Set the switches on the [I/O assignment] tab in the [PLC Parameter] screen of GX Developer.

(a) [I/O assignment] tab

Set the following to the slot to which the QD72P3C3 is mounted.

[Type]: Select [Intelli].

[Model name]: Input the model of the module.

[Points]: Select [32points].

[Start XY]: Input the start I/O number of the QD72P3C3.

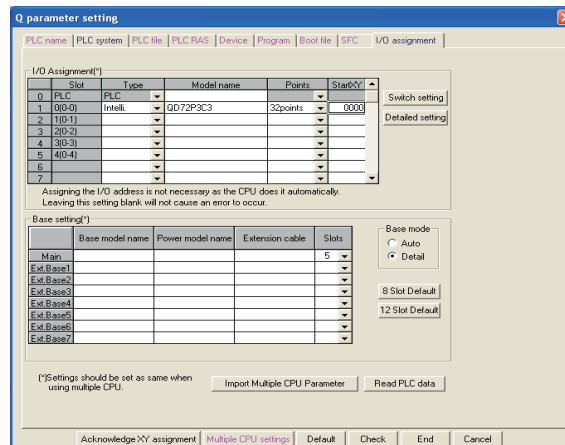

(b) [Switch setting for I/O and intelligent function module] screen

Click the **Switch setting** button on the [I/O assignment] tab to display the screen and set the switches from 1 to 3.

Entering the values in hexadecimal make the setting easier.

Change [Input format] to [HEX.] and enter values.

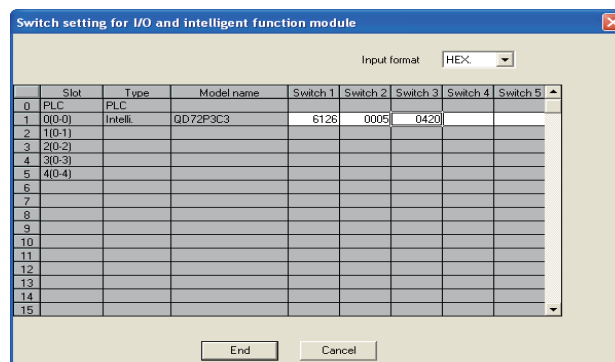

POINT

The values set on the [I/O assignment] tab in the [PLC Parameter] screen can be checked on the [Module's Detailed Information] screen displayed from the [System Monitor] screen of GX Developer. For details, refer to Section 12.3.

5.7 Simple Reciprocating Operation

Before operating the system, check the operation of the drive unit.
 (Operation must be checked after confirming that the installation, wiring, intelligent function module switch setting, and connection of the QD72P3C3 are normal. For details of the drive unit, refer to the manual of the drive unit used.)

The following describes the method of "simple reciprocating operation".

(1) Operation method

Using a sequence program, perform forward run/reserve run of JOG operation.
 (For details of JOG operation, refer to CHAPTER 10.)

(2) Setting item

Set JOG data in the sequence program. Default values can be used for the other data (such as parameters, positioning data).
 (Change the JOG data setting values according to the machine specifications.)

JOG data	Setting value (example)	Setting contents	Buffer memory address		
			Axis 1	Axis 2	Axis 3
[JOG.1] JOG speed	5000pulse/s	Set the speed for JOG operation.	40 41	140 141	240 241
[JOG.2] JOG ACC/DEC time	1000ms	Set the ACC/DEC time for JOG operation.	42	142	242

* For details of the setting contents, refer to "Section 4.3 List of JOG Data".

(3) Reciprocating operation program using JOG operation

The following is a program example for Axis 1.
 (When the QD72P3C3 is installed in slot 0 of the main base unit)

[Used device]

Device name	Device	Application	ON details	Remarks
Special relay	SM403	One scan OFF after RUN	-	-
QD72P3C3 I/O	Input	X0	Module READY signal	QD72P3C3: Normal
		X8	Axis 1 BUSY signal	Axis 1: In operation
	Output	Y0	Programmable controller CPU READY signal	Programmable controller CPU: Normal
		YC	Axis 1 forward run JOG start signal	Axis 1: Forward run JOG starting
		YD	Axis 1 reverse run JOG start signal	Axis 1: Reverse run JOG starting
External input (command)	X27	Forward run JOG command	Forward run JOG operation: Being commanded	JOG operation is disabled if X27 and X28 are both ON or both OFF.
	X28	Reverse run JOG command	Reverse run JOG operation: Being commanded	
Internal relay	M8	JOG operation flag	JOG operation	-

[Program example]

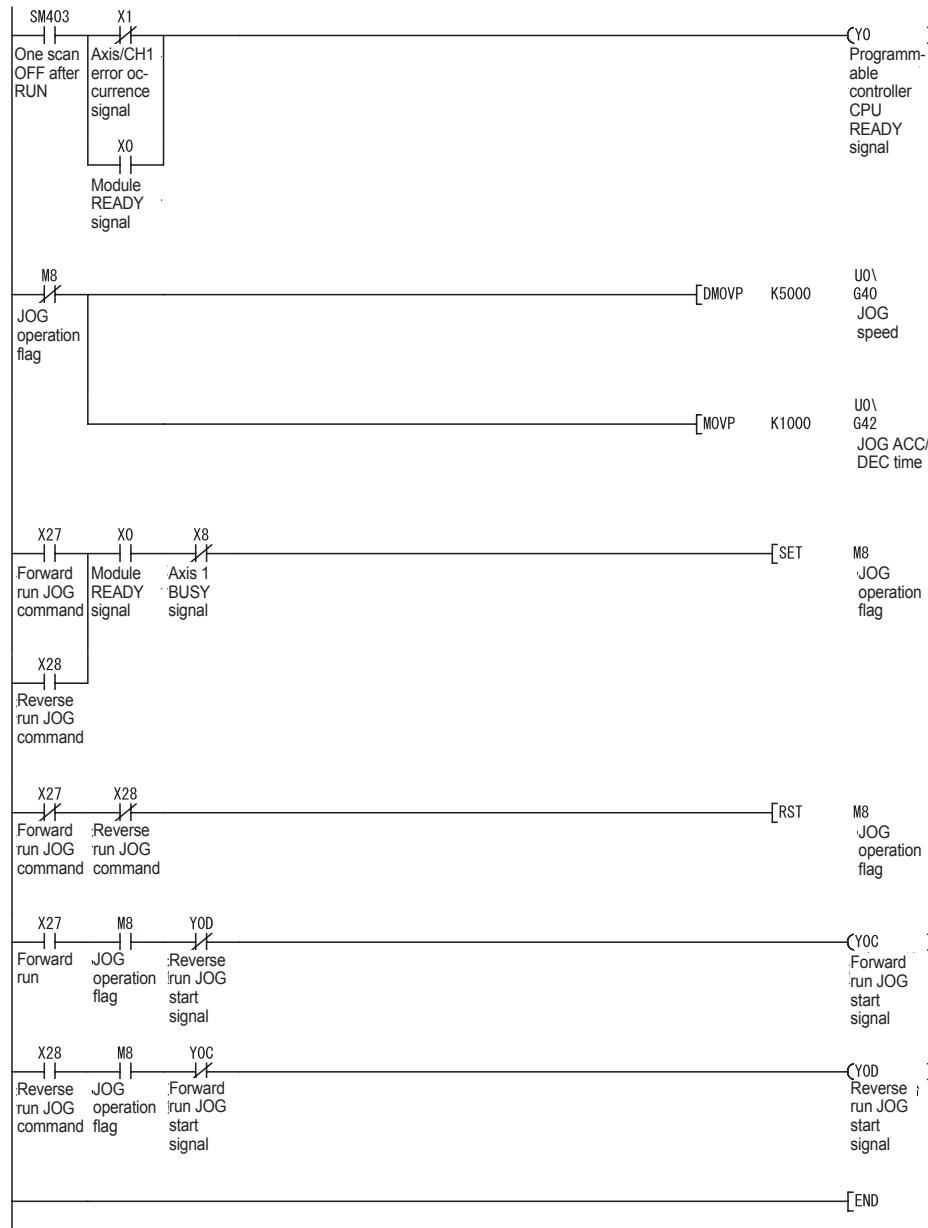

(4) Checking operation status

(a) Checking using GX Developer

Read the following monitor data using the monitor function (Buffer memory batch).

Axis monitor data	Monitor contents	Buffer memory address		
		Axis 1/ CH1	Axis 2/ CH2	Axis 3/ CH3
Md.1 Current feed value	Monitors the current position.	70 71	170 171	270 271
Md.2 Current speed	Monitors the current speed.	72 73	172 173	272 273
Md.4 Axis operation status	Monitors the operation status "2: JOG operation" of the axis.	76	176	276
Md.5 Axis/CH error code	Monitors details of the error occurrence.	77	177	277

* For details of the monitor contents, refer to "Section 4.5 List of Monitor Data".

(Example) Operation status of Axis 1 (GX Developer screen)

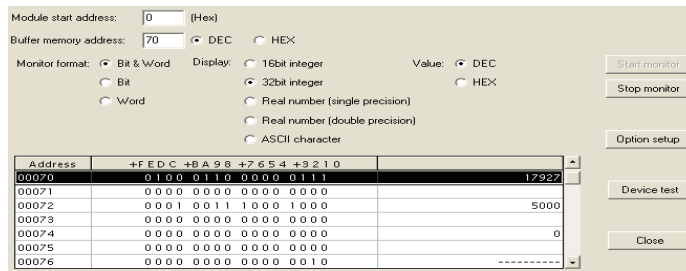

(b) Checking using GX Configurator-PT

Monitor the "current feed value", "current speed", "axis operation status", and "axis error code" on the [Monitor/Test] screen.

(For details, refer to "Section 6.6 Monitor/Test".)

(Example) Operation monitor of Axis 1 (Axis #1 Monitor/Test)

(GX Configurator-PT screen)

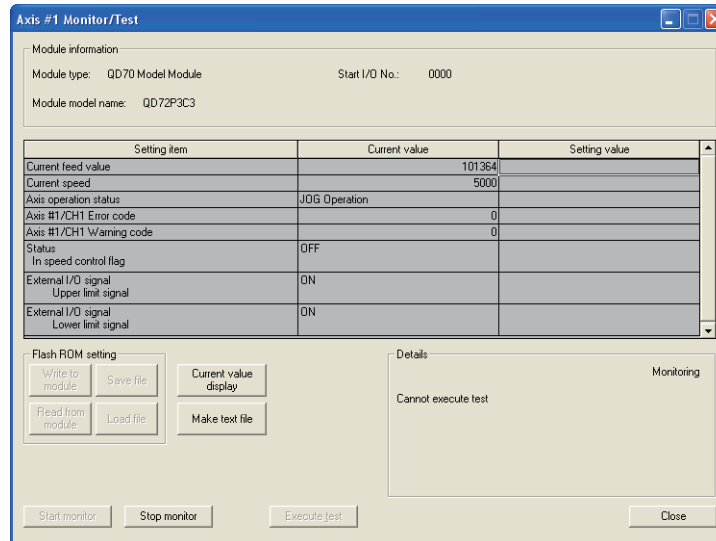

CHAPTER6 UTILITY PACKAGE (GX Configurator-PT)

The QD72P3C3 utility package (GX Configurator-PT) is software designed to make initial setting, auto refresh setting, monitor and others of the QD72P3C3 using dedicated screens, without being conscious of the I/O signals and buffer memory.
Use the utility package together with GX Developer (SW4D5C-GPPW-E or later).

6.1 Utility Package Functions

The following table shows the functions of the utility package.

Function	Description	Reference
Initial setting	<p>Makes the initial setting for each axis to operate the QD72P3C3. Sets the values of the items where the initial setting is required.</p> <p>[Setting items]</p> <ul style="list-style-type: none"> •Parameter •OPR data •Positioning data •Counter function parameter <p>(The initially set data are registered to programmable controller CPU parameters and automatically written to the QD72P3C3 when the programmable controller CPU changes to the RUN status.)</p>	Section 6.4
Auto refresh setting	<p>Sets the QD72P3C3 buffer memory to be automatically refreshed.</p> <p>[Auto refresh target buffer memory]</p> <ul style="list-style-type: none"> •Current feed value •Current speed •Count value •Axis operation status •Axis/CH error code •Axis/CH warning code <p>(The values stored in the QD72P3C3 buffer memory with auto refresh setting are automatically read when the programmable controller CPU executes the END instruction.)</p>	Section 6.5
Monitor/Test	<p>Monitors/tests the buffer memories and I/O signals of the QD72P3C3.</p> <ul style="list-style-type: none"> •Axis monitor/test •OPR monitor •Counter function monitor/test •X/Y monitor •ACC/DEC time calculation function 	Section 6.6

6.2 Installing and Uninstalling the Utility Package

For how to install or uninstall the utility package, refer to "Method of installing the MELSOFT Series" included in the utility package.

6.2.1 Handling precautions

The following explains the precautions on using the Utility package.

(1) For safety

Since the utility is add-in software for GX Developer, read "Safety Precautions" and the basic operating procedures in the GX Developer Operating Manual.

(2) About installation

GX Configurator-PT is add-in software for SW4D5C-GPPW-E or later versions. Therefore, GX Configurator-PT must be installed on the personal computer that has already SW4D5C-GPPW-E or later version installed.

(3) Screen error of Intelligent function module utility

Insufficient system resource may cause the screen to be displayed inappropriately while using the Intelligent function module utility.

If this occurs, close the Intelligent function module utility, GX Developer (program, comments, etc.), and other applications, and then start GX Developer and Intelligent function module utility again.

(4) To start the Intelligent function module utility

(a) In GX Developer, select "QCPU (Q mode)" for PLC series and specify a project. If any PLC series other than "QCPU (Q mode)" is selected, or if no project is specified, the Intelligent function module utility will not start.

(b) Multiple Intelligent function module utilities can be started. However, [Open parameters] and [Save parameters] operations under [Intelligent function module parameter] are allowed for one Intelligent function module utility only. Only the [Monitor/test] operation is allowed for the other utilities.

(5) Switching between two or more Intelligent function module utilities

When two or more Intelligent function module utility screens cannot be displayed side by side, select a screen to be displayed on the top of others using the task bar.

**(6) Number of parameters that can be set in GX Configurator-PT**

When multiple intelligent function modules are mounted, the number of parameter settings must not exceed the following limit.

When intelligent function modules are installed to:	Maximum number of settable parameters	
	Initial setting	Auto refresh setting
Q00J/Q00/Q01CPU	512	256
Q02/Q02H/Q06H/Q12H/Q25HCPU	512	256
Q02PH/Q06PH/Q12PH/Q25PHCPU	512	256
Q12PRH/Q25PRHCPU	512	256
Q00UJ/Q00U/Q01UCPU	512	256
Q02UCPU	2048	1024
Q03UD/Q04UDH/Q06UDH/Q10UDH/ Q13UDH/Q20UDH/Q26UDH/Q03UDE/ Q04UDEH/Q06UDEH/Q10UDEH/ Q13UDEH/Q20UDEH/Q26UDEHCPU	4096	2048
Q50UDEH/Q100UDEHCPU	Not supported	Not supported
MELSECNET/H remote I/O station	512	256

For example, if multiple intelligent function modules are installed to the MELSECNET/H remote I/O station, configure the settings in GX Configurator so that the number of parameter settings for all the intelligent function modules does not exceed the limit of the MELSECNET/H remote I/O station.

Calculate the total number of parameter settings separately for the initial setting and for the auto refresh setting.

The number of parameters that can be set for one module in GX Configurator-PT is as shown below.

Target module	Initial setting	Auto refresh setting
QD72P3C3	12 (fixed)	18 (Max.)

Example) Counting the number of parameter settings in Auto refresh setting

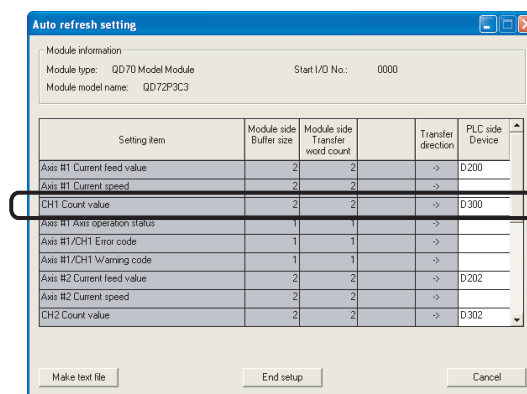

This one row is counted as one setting. Blank rows are not counted. Count up all the setting items on this screen, and add the total to the number of settings for other intelligent function modules to get a grand total.

6.2.2 Operating environment

This section explains the operating environment of the personal computer that runs GX Configurator-PT.

Item	Description
Installation (Add-in) target* ¹	Add-in to GX Developer Version 4 (English version) or later.* ²
Computer	Windows [®] -based personal computer
CPU	Refer to the following table "Used operating system and performance required for personal computer".
Required memory	
Hard disk space* ³	For installation
	For operation
Display	800 × 600 dots or more resolution* ⁴
Operating system	Microsoft [®] Windows [®] 95 Operating System (English version)
	Microsoft [®] Windows [®] 98 Operating System (English version)
	Microsoft [®] Windows [®] Millennium Edition Operating System (English version)
	Microsoft [®] Windows NT [®] Workstation Operating System Version 4.0 (English version)
	Microsoft [®] Windows [®] 2000 Professional Operating System (English version)
	Microsoft [®] Windows [®] XP Professional Operating System (English version)
	Microsoft [®] Windows [®] XP Home Edition Operating System (English version)
	Microsoft [®] Windows Vista [®] Home Basic Operating System (English version)
	Microsoft [®] Windows Vista [®] Home Premium Operating System (English version)
	Microsoft [®] Windows Vista [®] Business Operating System (English version)
	Microsoft [®] Windows Vista [®] Ultimate Operating System (English version)
Microsoft [®] Windows Vista [®] Enterprise Operating System (English version)	

* 1: Install GX Configurator-PT in GX Developer Version 4 or higher in the same language. GX Developer (English version) and GX Configurator-PT (Japanese version) cannot be used in combination, and GX Developer (Japanese version) and GX Configurator-PT (English version) cannot be used in combination.

* 2: GX Configurator-PT is not applicable to GX Developer Version 3 or earlier.

* 3: At least 15GB is required for Windows Vista[®].

* 4: Resolution of 1024 × 768 dots or more is recommended for Windows Vista[®].

Used operating system and performance required for personal computer

Operating system	Performance required for personal computer	
	CPU	Memory
Windows® 95	Pentium® 133MHz or more	32MB or more
Windows® 98	Pentium® 133MHz or more	32MB or more
Windows® Me	Pentium® 150 MHz or more	32MB or more
Windows NT® Workstation 4.0	Pentium® 133MHz or more	32MB or more
Windows® 2000 Professional	Pentium® 133MHz or more	64MB or more
Windows® XP Professional (Service Pack1 or later)	Pentium® 300MHz or more	128MB or more
Windows® XP Home Edition (Service Pack1 or later)	Pentium® 300MHz or more	128MB or more
Windows Vista® Home Basic	Pentium® 1GHz or more	1GB or more
Windows Vista® Home Premium	Pentium® 1GHz or more	1GB or more
Windows Vista® Business	Pentium® 1GHz or more	1GB or more
Windows Vista® Ultimate	Pentium® 1GHz or more	1GB or more
Windows Vista® Enterprise	Pentium® 1GHz or more	1GB or more

POINT

(1) The functions shown below are not available for Windows® XP and Windows Vista®.

If any of the following functions is attempted, this product may not operate normally.

- Start of application in Windows® compatible mode
- Fast user switching
- Remote desktop
- Large fonts (Details setting of Display Properties)

Also, 64-bit version Windows® XP and Windows Vista® are not supported.

(2) Use a USER authorization or higher in Windows Vista®.

6.3 Utility Package Operation

6.3.1 Common utility package operations

(1) Control keys

Special keys that can be used for operation of the utility package and their applications are shown in the table below.

Key	Application
Esc	Cancels the current entry in a cell. Closes the window.
Tab	Moves between controls in the window.
Ctrl	Used in combination with the mouse operation to select multiple cells for test execution.
Delete	Deletes the character where the cursor is positioned. When a cell is selected, clears all of the setting contents in the cell.
Back Space	Deletes the character where the cursor is positioned.
↑ ↓ ← →	Moves the cursor.
Page Up	Moves the cursor one page up.
Page Down	Moves the cursor one page down.
Enter	Completes the entry in the cell.

(2) Data created with the utility package

The following data or files that are created with the utility package can be also handled in GX Developer. Figure 6.1 shows respective data or files are handled in which operation.

(a) Intelligent function module parameter

This represents the data created in Auto refresh setting, and they are stored in an intelligent function module parameter file in a project created by GX Developer.

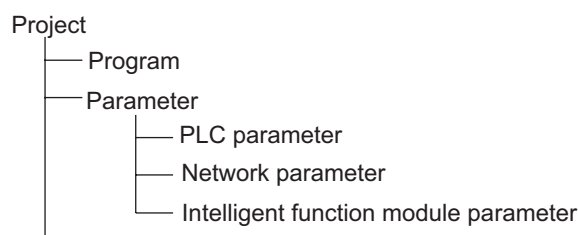

Steps 1) to 3) shown in Figure 6.1 are performed as follows:

- 1) From GX Developer, select:
[Project] → [Open project] / [Save] / [Save as]
- 2) On the intelligent function module selection screen of the utility, select:
[Intelligent function module parameter] → [Open parameters] / [Save parameters]
- 3) From GX Developer, select:
[Online] → [Read from PLC] / [Write to PLC] → "Intelligent function module parameters"
Alternatively, from the intelligent function module selection screen of the utility, select:
[Online] → [Read from PLC] / [Write to PLC]

(b) Text files

A text file can be created by clicking the button on the initial setting, Auto refresh setting, or Monitor/Test screen. The text files can be utilized to create user documents.

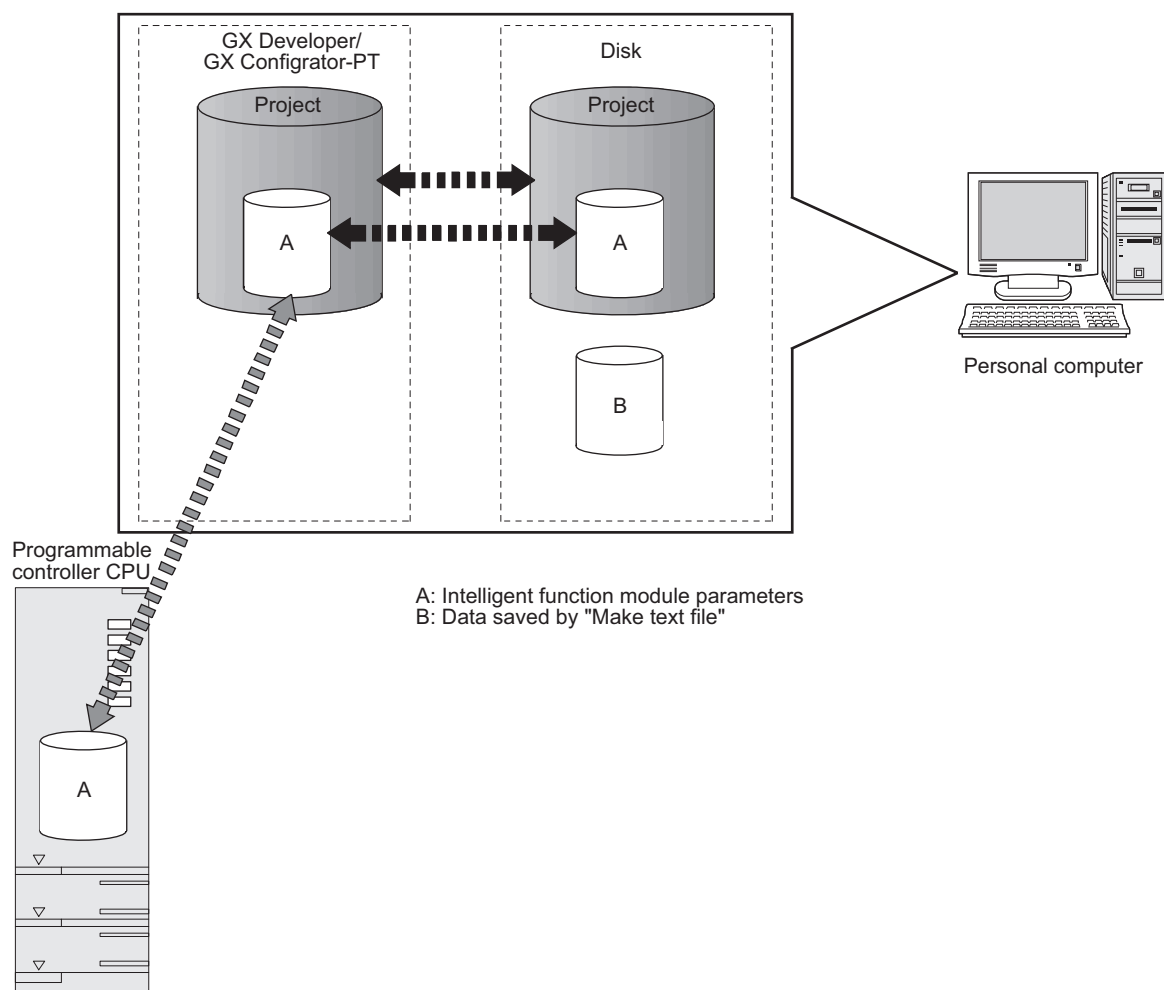
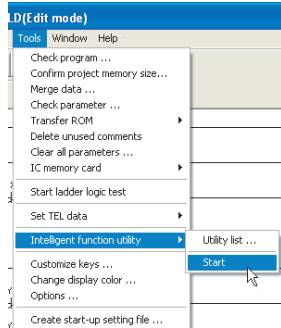

Figure 6.1 Correlation chart for data created with the utility package

6.3.2 Operation overview

GX Developer screen



[Tools] - [Intelligent function utility] - [Start]

Screen for selecting a target intelligent function module

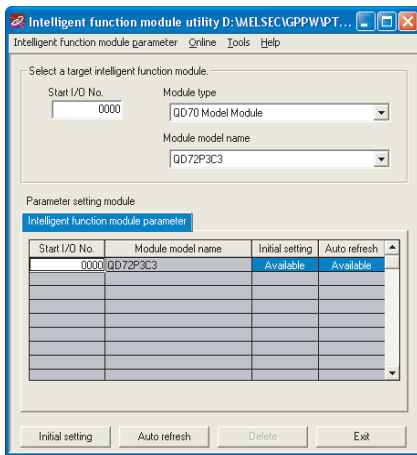

Refer to Section 6.3.3. Enter "Start I/O No.", and select "Module type" and "Module model name".

Initial setting

Auto refresh

Initial setting screen

Auto refresh setting screen

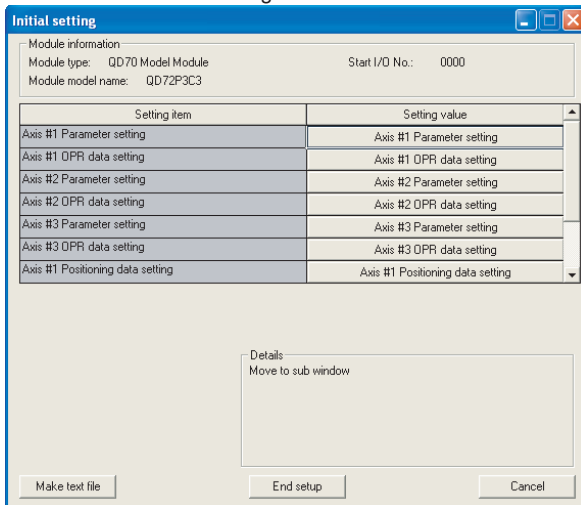

Refer to Section 6.4.

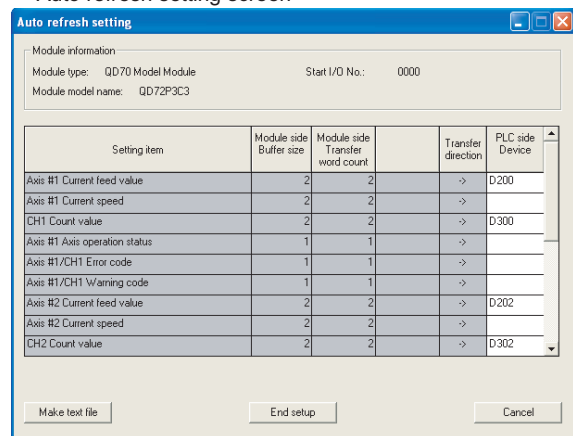

Refer to Section 6.5.

1) [Online] - [Monitor/Test]

Select monitor/test module screen

Monitor/Test

Select a module to be monitored/tested.

Monitor/Test screen

Setting item	Current value	Setting value
Module READY	Prepared	
PLC READY	ON	
Axis #1 Axis Operation status	Standby	
Axis #2 Axis Operation status	Standby	
Axis #3 Axis Operation status	Standby	
Axis #1/CH 1 Error occurrence*001	No Error	
Axis #2/CH 2 Error occurrence*002	No Error	
Axis #3/CH 3 Error occurrence*003	No Error	
Axis #1/CH 1 Warning occurrence*004	No Error	
Axis #2/CH 2 Warning occurrence*005	No Error	
Axis #3/CH 3 Warning occurrence*006	No Error	

Refer to Section 6.6.

6.3.3 Starting the Intelligent function module utility

[Operating procedure]

Intelligent function module utility is started from GX Developer.

[Tools] → [Intelligent function utility] → [Start]

[Setting screen]

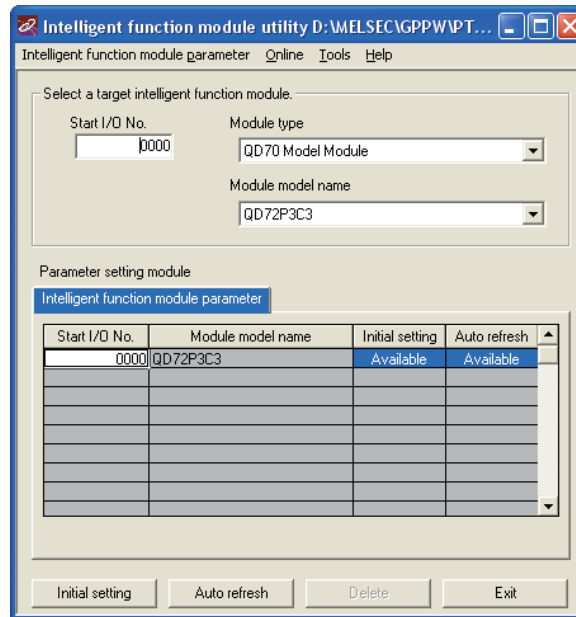

[Explanation of items]

(1) Activation of other screens

Following screens can be displayed from the intelligent function module utility screen.

(a) Initial setting screen

"Start I/O No. *1" → "Module type" → "Module model name" → Initial setting

(b) Auto refresh setting screen

"Start I/O No. *1" → "Module type" → "Module model name" → Auto refresh

(c) Select monitor/test module screen

[Online] → [Monitor/Test]

* 1 Enter the start I/O No. in hexadecimal.

(2) Command buttons

- Delete** Deletes the initial setting and auto refresh setting of the selected module.
- End** Closes this screen.

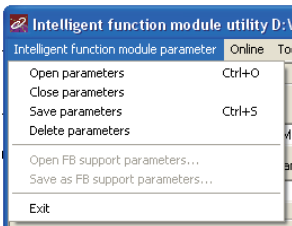
(3) Menu bar**(a) File menu**

Intelligent function module parameters of the project opened by GX Developer are handled.

- [Open parameters]** : Reads a parameter file.
- [Close parameters]** : Closes the parameter file. If any data are modified, a dialog asking for file saving will appear.
- [Save parameters]** : Saves the parameter file.
- [Delete parameters]** : Deletes the parameter file.
- [Exit]** : Closes this screen.

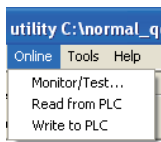
(b) Online menu

- [Monitor/Test]** : Activates the Select monitor/test module screen.
- [Read from PLC]** : Reads intelligent function module parameters from the CPU module.
- [Write to PLC]** : Writes intelligent function module parameters to the CPU module.

POINT

- (1) Saving intelligent function module parameters in a file
Since intelligent function module parameters cannot be saved in a file by the project saving operation of GX Developer, save them on the shown module selection screen.
- (2) Reading/writing intelligent function module parameters from/to a programmable controller CPU using GX Developer
 - Intelligent function module parameters can be read from and written into a programmable controller after having been saved in a file.
 - Set a target programmable controller CPU in GX Developer:
[Online] → [Transfer setup].
 - When the QD72P3C3 is mounted to the remote I/O station, use “Read from PLC” and “Write to PLC” of GX Developer.
- (3) Checking the required utility
While the start I/O is displayed on the Intelligent function module utility setting screen, "*" may be displayed for the model name.
This means that the required utility has not been installed or the utility cannot be started from GX Developer.
Check the required utility, selecting [Tools] - [Intelligent function utility] - [Utility list...] in GX Developer.

6.4 Initial Setting

[Purpose]

Make initial setting axis-by-axis for the QD72P3C3 to operate. The following items are data that need initial setting.

- Parameters
- OPR data
- Positioning data
- Counter function parameter

This initial setting makes sequence program setting unnecessary.

For more information on the setting details, refer to "CHAPTER 4 DATA USED FOR POSITIONING CONTROL".

[Operating procedure]

"Start I/O No.*" → "Module type" → "Module model name" → Initial setting

* Enter the start I/O No. in hexadecimal.

[Setting screen]

(Initial setting of parameters and OPR data)

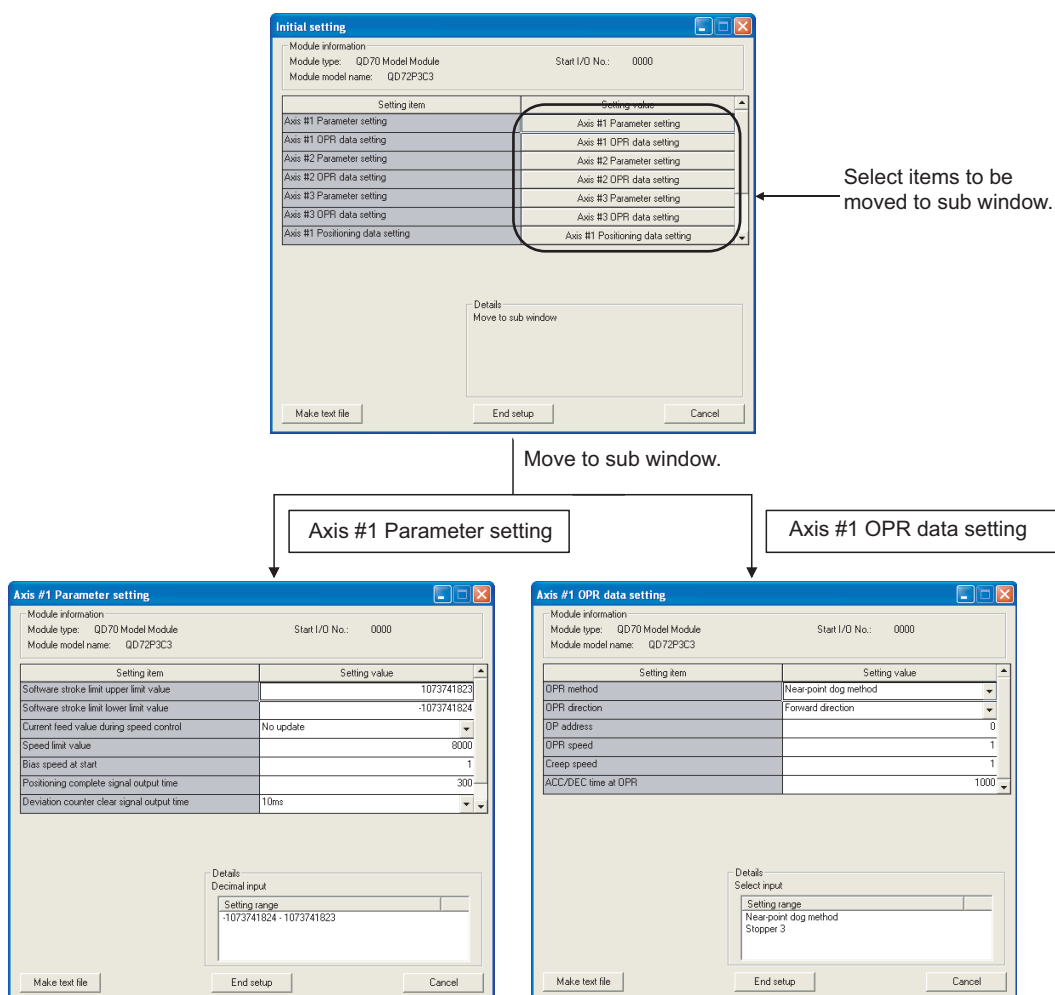

(Initial setting for positioning data and counter function parameter)

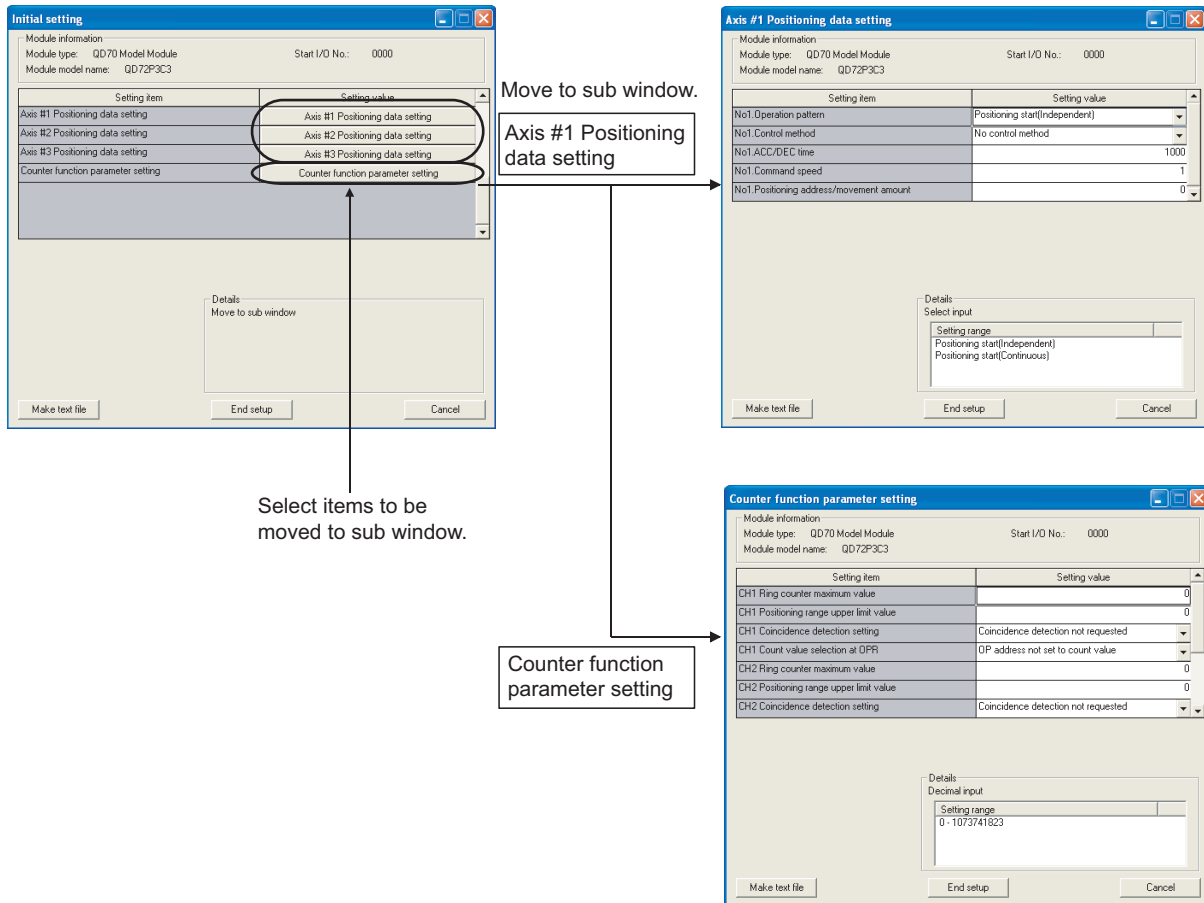

[Explanation of items]

(1) Setting item list

Setting item
Axis #1 Parameter setting
Axis #1 OPR data setting
Axis #2 Parameter setting
Axis #2 OPR data setting
Axis #3 Parameter setting
Axis #3 OPR data setting
Axis #1 Positioning data setting
Axis #2 Positioning data setting
Axis #3 Positioning data setting
Counter function parameter setting

(2) Command button

- Make text file** Creates a file containing the screen data in text file format.
- End setup** Saves the set data and ends the operation.
- Cancel** Cancels the setting and ends the operation.

POINT

Initial settings are stored in an intelligent function module parameter file. After being written to the CPU module, the initial setting is made effective by either (1) or (2).

- (1) Cycle the RUN/STOP switch of the CPU module: STOP → RUN → STOP → RUN.
- (2) With the RUN/STOP switch set to RUN, turn off and then on the power or reset the CPU module.

If the initialization settings have been written by a sequence program, the initialization settings will be executed during the STOP → RUN of the CPU module. Arrange so that the initial settings written by the sequence program are re-executed during the STOP → RUN of the CPU module.

6.5 Auto Refresh Setting

[Purpose]

Configure the QD72P3C3's buffer memory for automatic refresh.

There are the following setting items as the auto refresh setting parameters.

- Current feed value
- Current speed
- Count value
- Axis operation status
- Axis/CH error code
- Axis/CH warning code

This auto refresh setting eliminates the need for reading by sequence programs.

[Operating procedure]

"Start I/O No.*" → "Module type" → "Module model name" → Auto refresh

* Enter the start I/O No. in hexadecimal.

[Setting screen]

Setting item	Module side Buffer size	Module side Transfer word count	Transfer direction	PLC side Device
Axis #1 Current feed value	2	2	->	D200
Axis #1 Current speed	2	2	->	
CH1 Count value	2	2	->	D300
Axis #1 Axis operation status	1	1	->	
Axis #1/CH1 Error code	1	1	->	
Axis #1/CH1 Warning code	1	1	->	
Axis #2 Current feed value	2	2	->	D202
Axis #2 Current speed	2	2	->	
CH2 Count value	2	2	->	D302

[Explanation of items]

(1) Setting item list

Setting item
Axis Current feed value
Axis Current speed
CH Count value
Axis operation status
Axis/CH Error code
Axis/CH Warning code

(2) Items

"Module side Buffer size": Displays the buffer memory size of the setting item.

"Module side Transfer word count": Displays the number of words to be transferred.

"Transfer direction": "←" indicates that data are written from the programmable controller CPU to the buffer memory.

"→" indicates that data are loaded from the buffer memory to the programmable controller CPU.

"PLC side Device": Enter a CPU module side device that is to be automatically refreshed.

Applicable devices are X, Y, M, L, B, T, C, ST, D, W, R, and ZR.

When using bit devices X, Y, M, L or B, set a number that can be divided by 16 points (examples: X10, Y120, M16, etc.).

Also, buffer memory data are stored in a 16-point area, starting from the specified device number. For example, if X10 is entered, data are stored in X10 to X1F.

(3) Command button

Creates a file containing the screen data in text file format.

Saves the set data and ends the operation.

Cancels the setting and ends the operation.

☒ POINT

- The auto refresh settings are stored in an intelligent function module parameter file. The auto refresh settings become effective by turning the power OFF and then ON or resetting the CPU module after writing the intelligent function module parameters to the CPU module.
- The auto refresh settings cannot be changed from sequence programs. However, processing equivalent to auto refresh can be added using the FROM/TO instruction in the sequence program.

6.6 Monitor/Test

6.6.1 Monitor/Test screen

[Purpose]

Start buffer memory monitoring/testing and I/O signal monitoring/testing from this screen.
(Refer to "Section 4.5 List of monitor data" for details of monitor data.)

[Operating procedure]

Select monitor/test module screen → "Start I/O No.*" → "Module type" → "Module model name" →

* Enter the start I/O No. in hexadecimal.

The screen can also be started from System monitor of GX Developer Version 6 or later.
Refer to the GX Developer Operating Manual for details.

[Setting screen]

(Axis Monitor/Test, OPR Monitor, Counter function Monitor/Test)

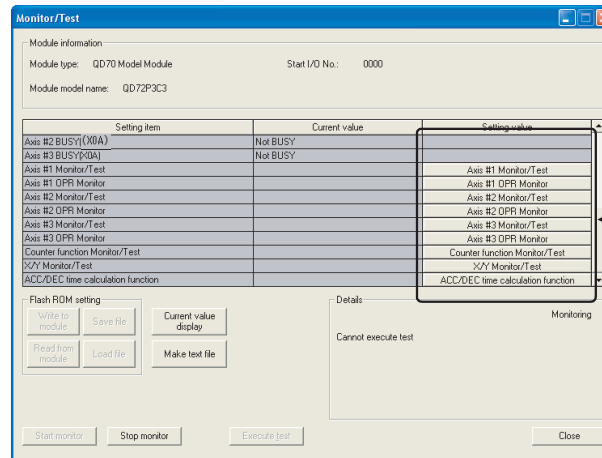

Select items to be moved to sub window.

Axis #1 Monitor/Test

Axis #1 OPR Monitor

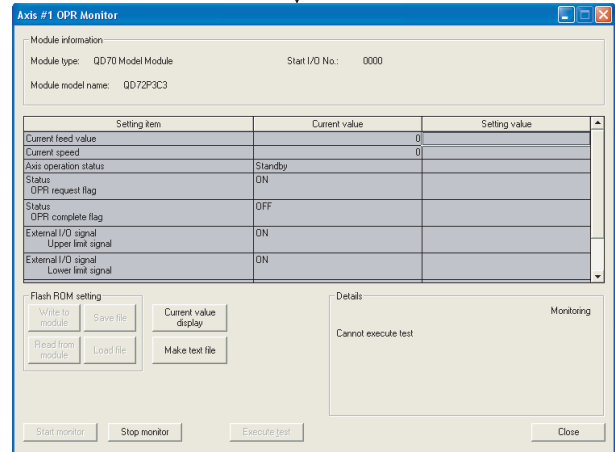
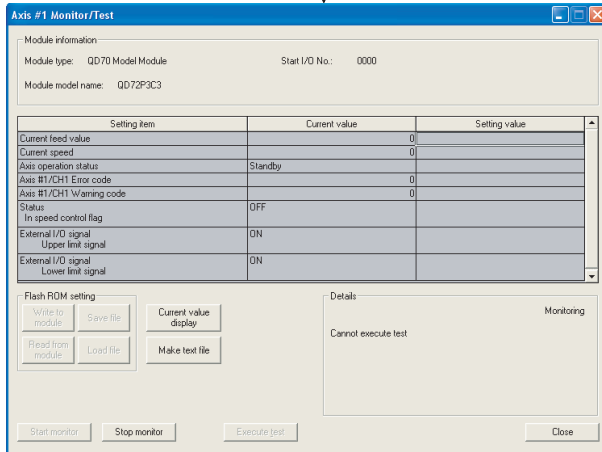

Counter function Monitor/Test

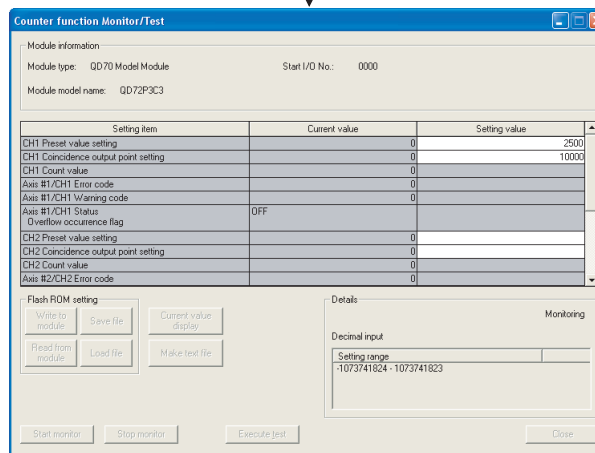

(X/Y Monitor)

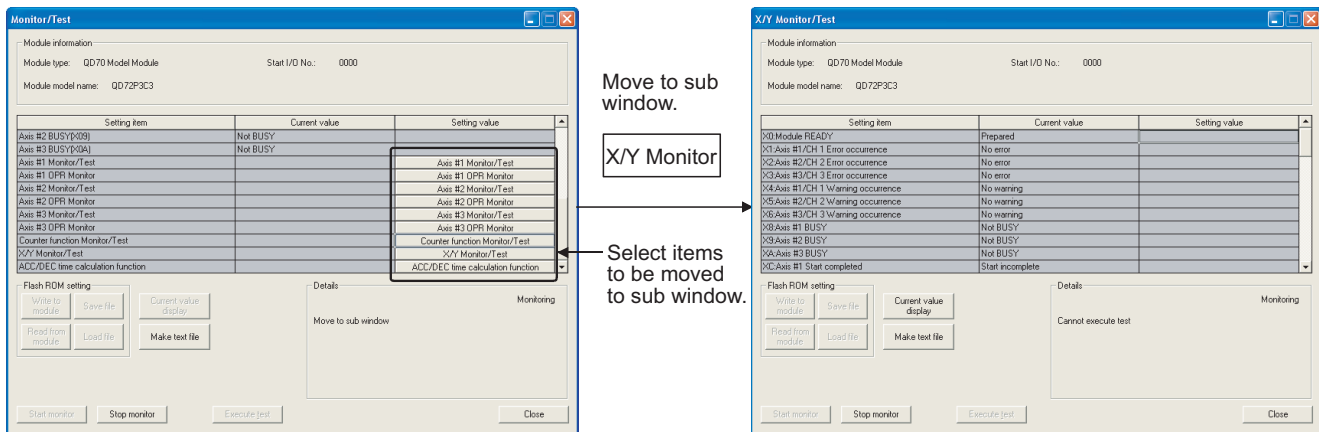

[Explanation of items]

(1) Setting item list

Setting item
Module READY
Programmable controller CPU READY
Axis #1 Operation status
Axis #2 Operation status
Axis #3 Operation status
Axis #1/CH 1 Error occurrence(X01)
Axis #2/CH 2 Error occurrence(X02)
Axis #3/CH 3 Error occurrence(X03)
Axis #1/CH 1 Warning occurrence(X04)
Axis #2/CH 2 Warning occurrence(X05)
Axis #3/CH 3 Warning occurrence(X06)
Axis #1 BUSY(X08)
Axis #2 BUSY(X09)
Axis #3 BUSY(X0A)
Axis #1 Monitor/Test
Axis #1 OPR Monitor
Axis #2 Monitor/Test
Axis #2 OPR Monitor
Axis #3 Monitor/Test
Axis #3 OPR Monitor
Counter function Monitor/Test
X/Y Monitor
ACC/DEC time calculation function

(2) Items

"Setting item": Displays I/O signals and buffer memory names.

"Current value": Monitors the I/O signal states and present buffer memory values.

"Setting value": Enter or select values to be written into the buffer memory for test operation (Axis Error Reset).

(3) Command button

Current value display Displays the current value of the item selected.

(This is used to check the text that cannot be displayed in the current value field. However, in this utility package, all items can be displayed in the display fields).

Make text file Creates a file containing the screen data in text file format.

Start monitor / **Stop monitor** Selects whether or not to monitor current values.

Execute test Performs a test on the selected items.

Click this button after selecting "Error Reset Request" in the Setting value field of "Axis Error Reset" on the Axis monitor/test sub window.

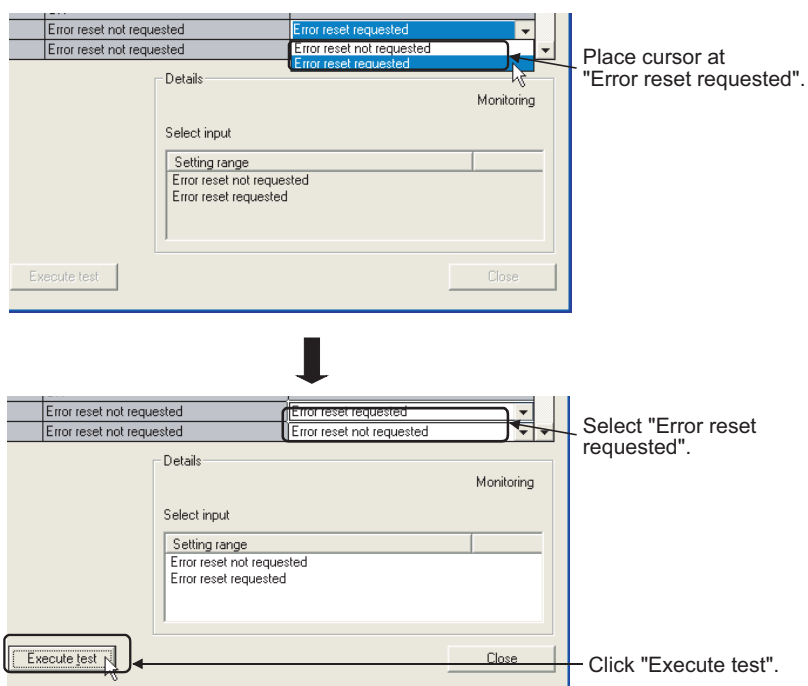

Close Closes the currently open screen and returns to the previous screen.

6.6.2 ACC/DEC time calculation function screen

[Purpose]

The QD72P3C3 processes acceleration as integer. Therefore, the difference may be generated between actual ACC/DEC time and set ACC/DEC time.

With this function, actual ACC/DEC time can be calculated by entering parameters required for calculating ACC/DEC time.

For details of ACC/DEC time, refer to "Section 11.6.1 Calculating actual ACC/DEC time".

[Operating procedure]

Select monitor/test module screen → "Start I/O No.*" → "Module type" →

"Module model name" →

*Enter the start I/O No. in hexadecimal.

The screen can also be started from System monitor of GX Developer Version 6 or later.

Refer to the GX Developer Operating Manual for details.

[Setting screen]

ACC/DEC time calculation Function

QD72P3C3 module processes acceleration(value calculated based on the set value 1. - 4.) as integer. Therefore, the difference might be generated between Actual ACC/DEC time(9.) and ACC/DEC time(3.). An "Actual ACC/DEC time" can be calculated by inputting set value 1.- 4. on this dialog.

Setting

1.Command speed(pps)

2.Bias speed at start(pps)

3.ACC/DEC time(ms)

4.Speed limit value(pps)

Result

5.Acceleration

6.Actual acceleration

7.Difference(%)

8.Difference(ms)

9.Actual ACC/DEC time(ms)

Details

6. is a half-adjust value of 5.
7. and 8. is calculated as follows.

$$7. = [(5. - 6.) / 6.] * 100.$$

$$8. = 9. - 3.$$

[Explanation of items]

- Enter parameters required for calculating acceleration into the "Setting" 1. to 4.

Parameters entered to the "Setting" 1. to 3. depend on control contents.

Control contents	Parameter entered to 1.	Parameter entered to 2.	Parameter entered to 3.
OPR control	<input type="text" value="Pr.13"/> OPR speed	<input type="text" value="Pr.14"/> Creep speed	<input type="text" value="Pr.15"/> ACC/DEC time at OPR
Positioning control	<input type="text" value="Da.4"/> Command speed	<input type="text" value="Pr.5"/> Bias speed at start	<input type="text" value="Da.3"/> ACC/DEC time
JOG operation	<input type="text" value="JOG.1"/> JOG speed	<input type="text" value="Pr.5"/> Bias speed at start	<input type="text" value="JOG.2"/> JOG ACC/DEC time

- Enter " Speed limit value" for the "Setting" 4.
- Click . Calculation results are displayed in the "Result" 5. to 9.

5. Acceleration	Displays the acceleration calculated according to the "Setting" 1. to 4.
6. Actual acceleration	Displays the rounded value of 5. Acceleration. Actual acceleration/deceleration operation is performed with this acceleration.
7. Difference (%)	Displays the difference between 5. Acceleration and 6. Actual acceleration. (The displayed value is the difference over 5. Acceleration.)
8. Difference (ms)	Displays the difference between 3. ACC/DEC time and 9. Actual ACC/DEC time (9. -3.).
9. Actual ACC/DEC time (ms)	Displays the actual ACC/DEC time.

CHAPTER 7 SEQUENCE PROGRAM USED FOR POSITIONING CONTROL

This chapter describes sequence programs of the positioning control system using the QD72P3C3.

7.1 Precautions for Creating Program

(1) System configuration

Unless otherwise specified, the sequence programs in this chapter are for the following system.

For the applications of the devices used, refer to Section 7.2.

(a) System configuration

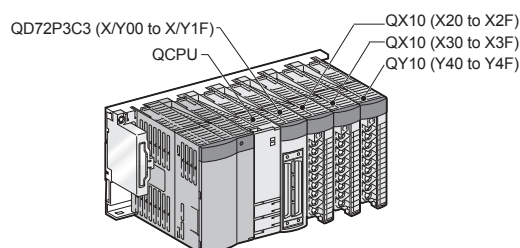

(b) Setting conditions of the intelligent function module switch

Switch No.	Setting item	Setting contents	Setting value
Switch 1	Pulse output mode	0: CW/CCW mode	0000H
	Pulse output logic selection	0: Negative logic	
	Deviation counter clear output logic selection	0: Negative logic	
	Zero signal input logic selection	0: Negative logic	
Switch 2	Near-point dog signal input logic selection	0: Negative logic	0000H
	Lower limit signal input logic selection	0: Negative logic	
	Upper limit signal input logic selection	0: Negative logic	
Switch 3	Pulse input mode	0: CW/CCW	0000H
	Counter format	0: Linear counter	
Switch 4	Reserved		0000H
Switch 5	Reserved		0000H

(2) Communication with QD72P3C3

There are two methods for communication with the QD72P3C3 using the sequence program: a method using an "intelligent function device" and a method using the FROM/TO instruction.

When using the FROM/TO instruction for communication with the QD72P3C3, change the circuit incorporating the "intelligent function device" as follows.

(a) When the circuit uses the "intelligent function device" on the destination (D) side of the MOV instruction, change the instruction to the TO instruction.

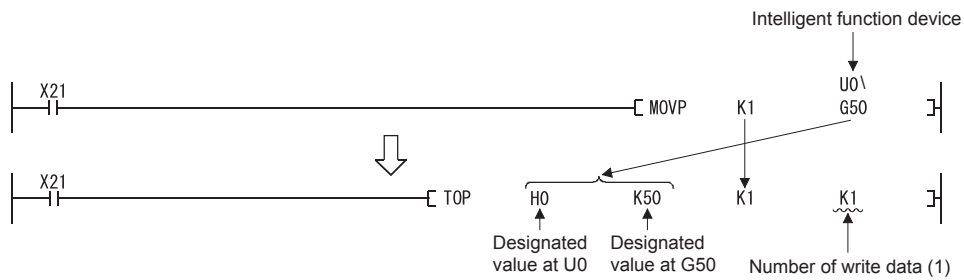

(b) When the circuit uses the "intelligent function device" on the source (S) side and the destination (D) side of the MOV instruction, change the instruction to the FROM instruction and the TO instruction.

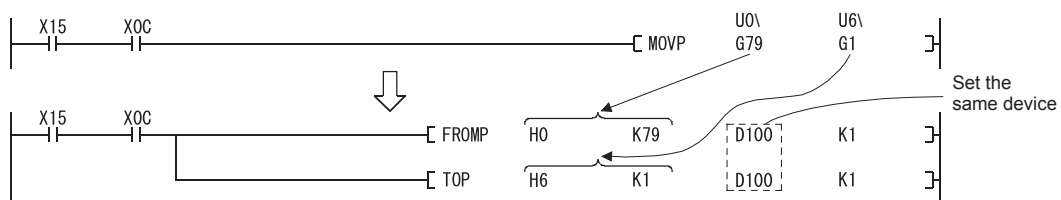

(c) When the circuit uses the "intelligent function device" for the COMPARISON instruction, change the instruction to the FROM instruction and the COMPARISON instruction.

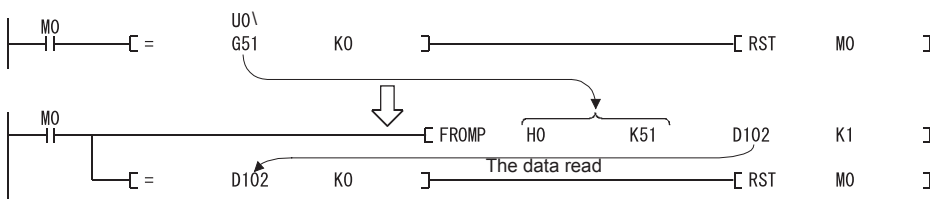

(d) When the circuit uses the "intelligent function device" for the WAND instruction, change the instruction to the FROM instruction and the WAND instruction.

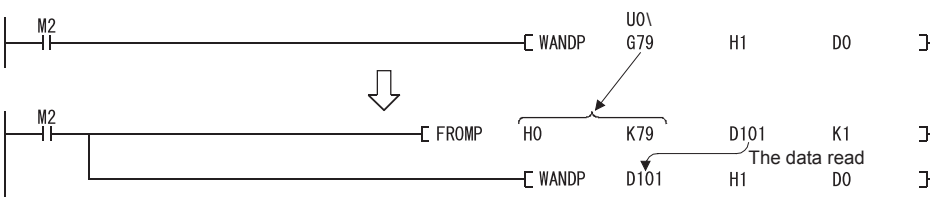

Remark

For intelligent function devices, refer to the User's Manual (Function Explanation, Program Fundamentals) for the CPU module used.

For details of the instructions used in the sequence program, refer to the MELSEC-Q/L Programming Manual (Common Instructions).

.....

7.2 List of Devices Used

In "Section 7.4 Positioning Control Program Examples", the devices to be used are assigned as indicated in the following table.

The I/O numbers for the QD72P3C3 indicate those when the QD72P3C3 is mounted in the slot 0 of the main base.

When mounting the QD72P3C3 in the slot other than the slot 0 of the main base, change the I/O number for the mounted position.

In addition, change the external inputs, internal relays, and data registers according to the system used.

(1) I/O and external inputs of the QD72P3C3

Device name	Device			Application	ON details	
	Axis 1/ CH1	Axis 2/ CH2	Axis 3/ CH3			
I/O of the QD72 P3C3	Input	X0			Module READY signal	QD72P3C3 prepared
		X01	X02	X03	Axis/CH error occurrence signal	Axis/CH error occurring
		X04	X05	X06	Axis/CH warning occurrence signal	Axis/CH warning occurring
		X08	X09	X0A	BUSY signal	BUSY (running)
		X0C	X0D	X0E	Start complete signal	Start complete
		X10	X11	X12	Positioning complete signal	Positioning control complete
		X14	X18	X1C	Count value large	Count value large detected
		X15	X19	X1D	Count value coincidence	Count value coincidence detected
	X16	X1A	X1E	Count value small	Count value small detected	
	Output	Y0			Programmable controller CPU READY signal	Programmable controller CPU prepared
		Y01	Y02	Y03	Axis/CH error reset signal	Axis/CH error reset being requested
		Y04	Y05	Y06	Axis stop signal	Stop being requested
		Y08	Y09	Y0A	Positioning start signal	Start being requested
		Y0C	Y0E	Y10	Forward run JOG start signal	Forward run JOG being started
		Y0D	Y0F	Y11	Reverse run JOG start signal	Reverse run JOG being started
Y14		Y15	Y16	Coincidence signal reset command	Coincidence signal reset being commanded	
Y18	Y19	Y1A	Preset command	Preset being requested		
Y1C	Y1D	Y1E	Count enable command	Count enable being requested		

7

SEQUENCE PROGRAM USED FOR POSITIONING CONTROL

MELSEC Q series

Device name	Device			Application	ON details
	Axis 1/ CH1	Axis 2/ CH2	Axis 3/ CH3		
External input (command)	X20	-		OPR request OFF command	OPR request OFF being commanded
	X21			Machine OPR control command	Machine OPR control being commanded
	X22			Fast OPR control command	Fast OPR control being commanded
	X23			1-axis linear control start command	1-axis linear control start being commanded
	X24			Speed control start command	Speed control start being commanded
	X25			Current value change command	Current value change being commanded
	X26			Positioning control start signal command	Positioning control start signal being commanded
	X27			Forward run JOG command	Forward run JOG operation being commanded
	X28			Reverse run JOG command	Reverse run JOG operation being commanded
	X29			Speed change command	Speed change being commanded
	X2A			Error reset command	Error reset being commanded
	X2B			Stop command	Stop being commanded
	X2C			Count operation start command	Count operation start being commanded
	X2D			Count operation stop command	Count operation stop being commanded
	X2E			Count value read command	Count value read being commanded
	X2F			Count value coincidence clear command	Count value coincidence clear being commanded
X30	Preset command	Preset being commanded			
External output (check)	Y40	-		Coincidence confirmation LED signal	Counter coincidence being detected
	Y41			Overflow occurrence confirmation LED signal	Overflow occurring

7 SEQUENCE PROGRAM USED FOR POSITIONING CONTROL

(2) Internal relays of the QD72P3C3

Device name	Device			Application	ON details
	Axis 1/ CH1	Axis 2/ CH2	Axis 3/ CH3		
Internal relay	M0	-		Initial data setting complete	Initial data setting complete
	M1			OPR request OFF command	OPR request OFF being commanded
	M2			OPR request OFF command pulse	OPR request OFF commanded
	M3			OPR request OFF command storage	OPR request OFF command held
	M4			Fast OPR control command	Fast OPR control being requested
	M5			Fast OPR control command storage	Fast OPR control command held
	M6			Positioning control start command pulse	Positioning control start commanded
	M7			Positioning control start command storage	Positioning control start signal command held
	M8			JOG operation flag	JOG operation in progress
	M9			Speed change command pulse	Speed change commanded
	M10			Speed change command storage	Speed change command held
	M11			Error reset command pulse	Error reset commanded
M12	Stop command pulse	Stop commanded			

(3) Data registers (for Axis 1)

Device name	Device	Stored data	Setting value			
Data register	D0	Parameter				
	D1			Pr.1 Software stroke limit upper limit	100000000pulse	
	D2			Pr.2 Software stroke limit lower limit	-100000000pulse	
	D3					
	D5			Pr.3 Current feed value during speed control	0 (No update)	
	D6			Pr.4 Speed limit value	10000pulse/s	
	D7					
	D8					
	D9			Pr.5 Bias speed at start	100pulse/s	
	D10					
	D11			Pr.6 Positioning complete output time	100ms	
	D11			Pr.7 Deviation counter clear signal output time	2 (10ms)	
	D13			Pr.9 Current feed value, count value simultaneous change function selection	1 (update count value together)	
	D20	OPR data	Pr.10 OPR method	0 (Near-point dog method)		
	D21		Pr.11 OPR direction	0 (Forward direction)		
	D22		Pr.12 OP address	0pulse		
	D23					
	D24		Pr.13 OPR speed	20000pulse/s		
	D25					
	D26					
	D27		Pr.14 Creep speed	1000pulse/s		
	D28	Pr.15 ACC/DEC time at OPR	1000ms			
	D30	Counter data				
	D31				Pr.16 Ring counter upper limit value	0
	D32				Pr.17 Positioning range upper limit value	0
	D33					
	D34				Pr.18 Coincidence detection setting	1 (coincidence detection requested)
	D35				Pr.19 Count value selection at OPR	1 (set)
	D90	Positioning data (for position control)	Da.1 Operation pattern	0 (Positioning start (independent))		
	D91		Da.2 Control method	1 (1-axis linear control (ABS))		
	D92		Da.3 ACC/DEC time	1000ms		
	D94		Da.4 Command speed	30000pulse/s		
	D95					
D96						
D97	Da.5 Positioning address/movement amount		250000pulse			
D100	Positioning data (for speed control)	Da.1 Operation pattern	0 (Positioning start (independent))			
D101		Da.2 Control method	3 (Speed control (Forward run))			
D102		Da.3 ACC/DEC time	1000ms			
D104		Da.4 Command speed	40000pulse/s			
D105						
D110	Positioning data (for current value change)	Da.1 Operation pattern	0 (Positioning start (independent))			
D111		Da.2 Control method	5 (current value change)			
D116		Da.5 Positioning address/movement amount	300000pulse			
D117						

(Continued to the next page)

7

SEQUENCE PROGRAM USED FOR POSITIONING CONTROL

Device name	Device	Stored data	Setting value
Data resister	D120	OPR request flag ([Md.7] Status: bit1)	-
	D56	[Cd.5] Start method	Varies depending on the operation
	D50	[Cd.1] New speed value	2000pulse/s
	D51		
	D52	[Cd.2] ACC/DEC time at speed change	1000ms
	D54	[Cd.3] Speed change request	-
	D77	[Md.5] Axis/CH error code	-
	D74	[Md.3] Count value	-
	D75		
	D121	Overflow occurrence flag ([Md.7] Status: bit3)	-

7.3 Creating a Program

This section describes "positioning control operation programs" actually used. The programs designed to perform the functions described in "PART 2 CONTROL DETAILS AND SETTING" are installed in the "positioning control operation programs" described in Section 7.3.2. (To monitor control, add a necessary monitor program according to the system. For monitor items, refer to "Section 4.5 Monitor Data List".)

7.3.1 General configuration of program

The general configuration of the "positioning control operation program" is shown below.

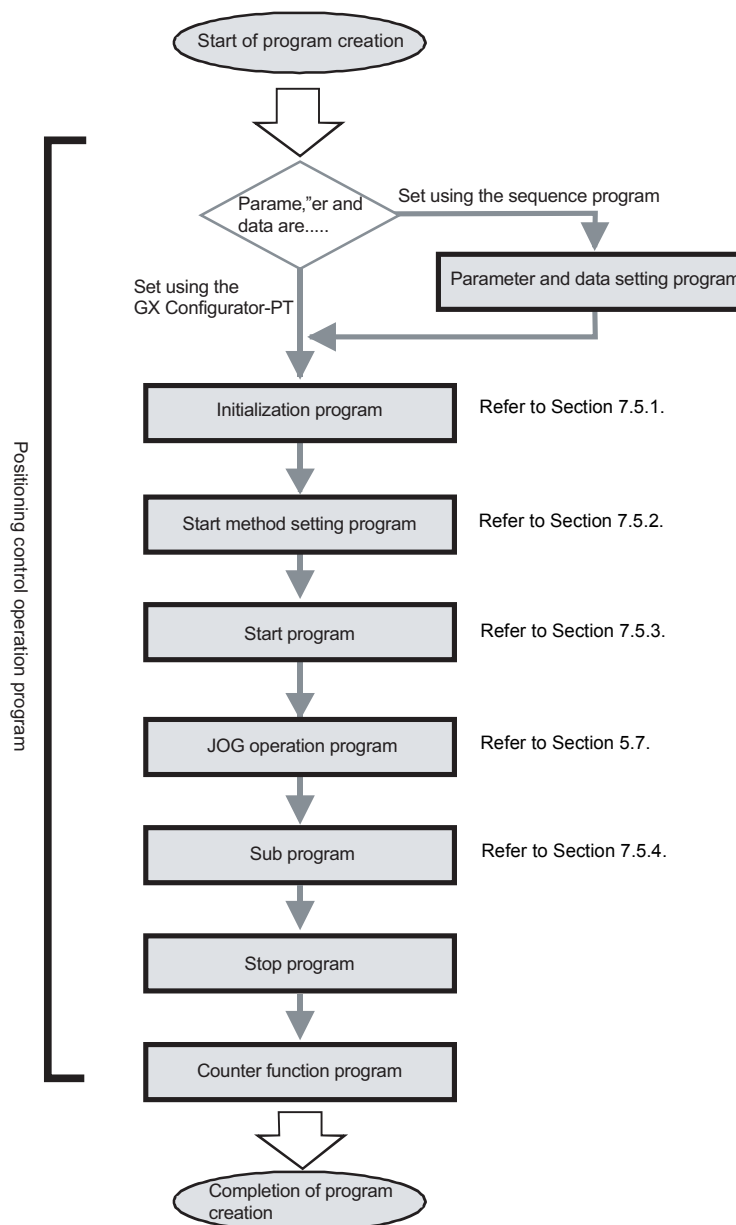

7.3.2 Positioning control operation program

The following are individual programs which comprise the "positioning control operation programs". When creating a program, refer to each section of the corresponding program and "Section 7.4 Positioning Control Program Examples" and create an operation program according to the positioning control system. (The following programs are numbered. Create programs in order of the numbers is recommended.)

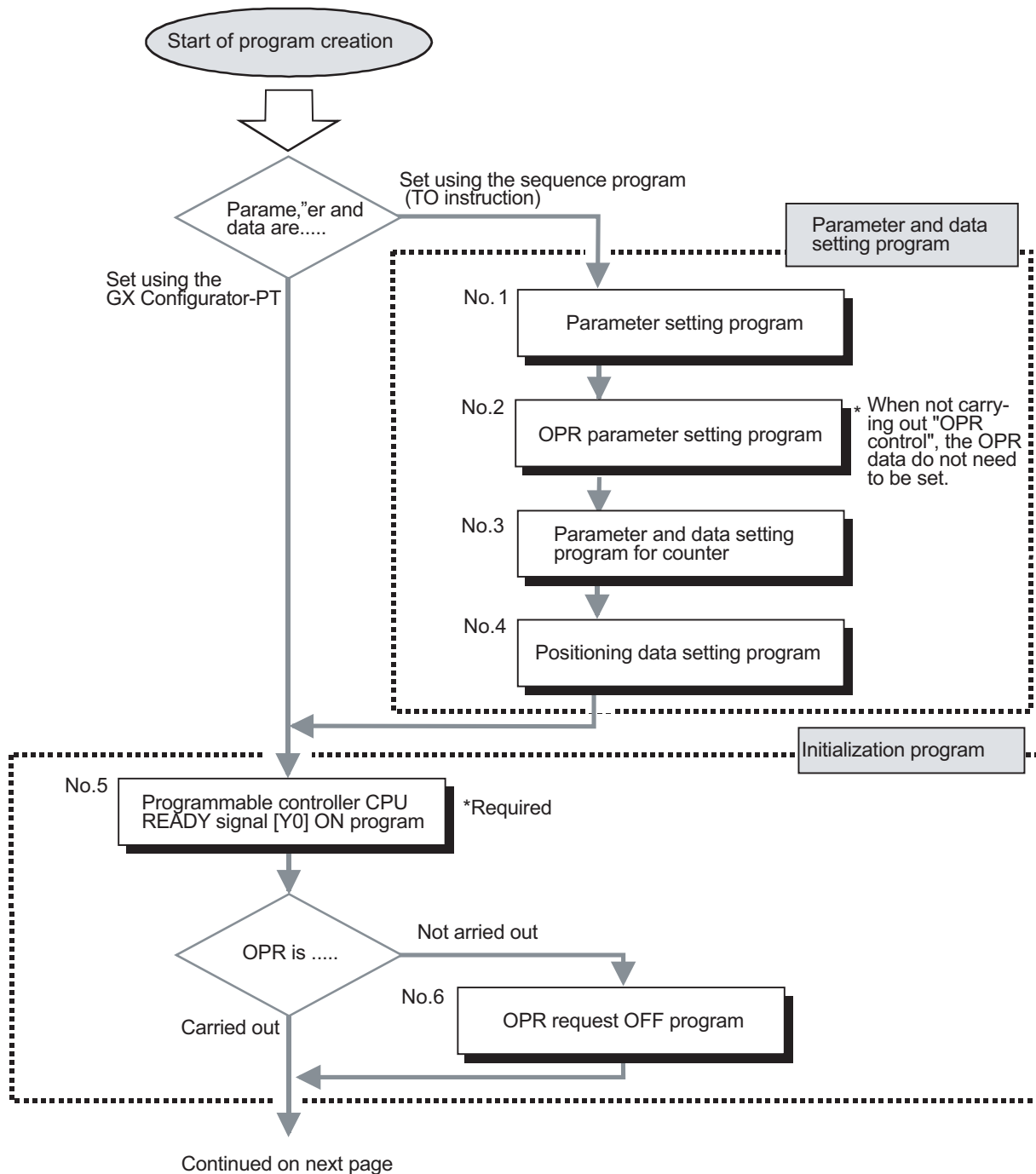

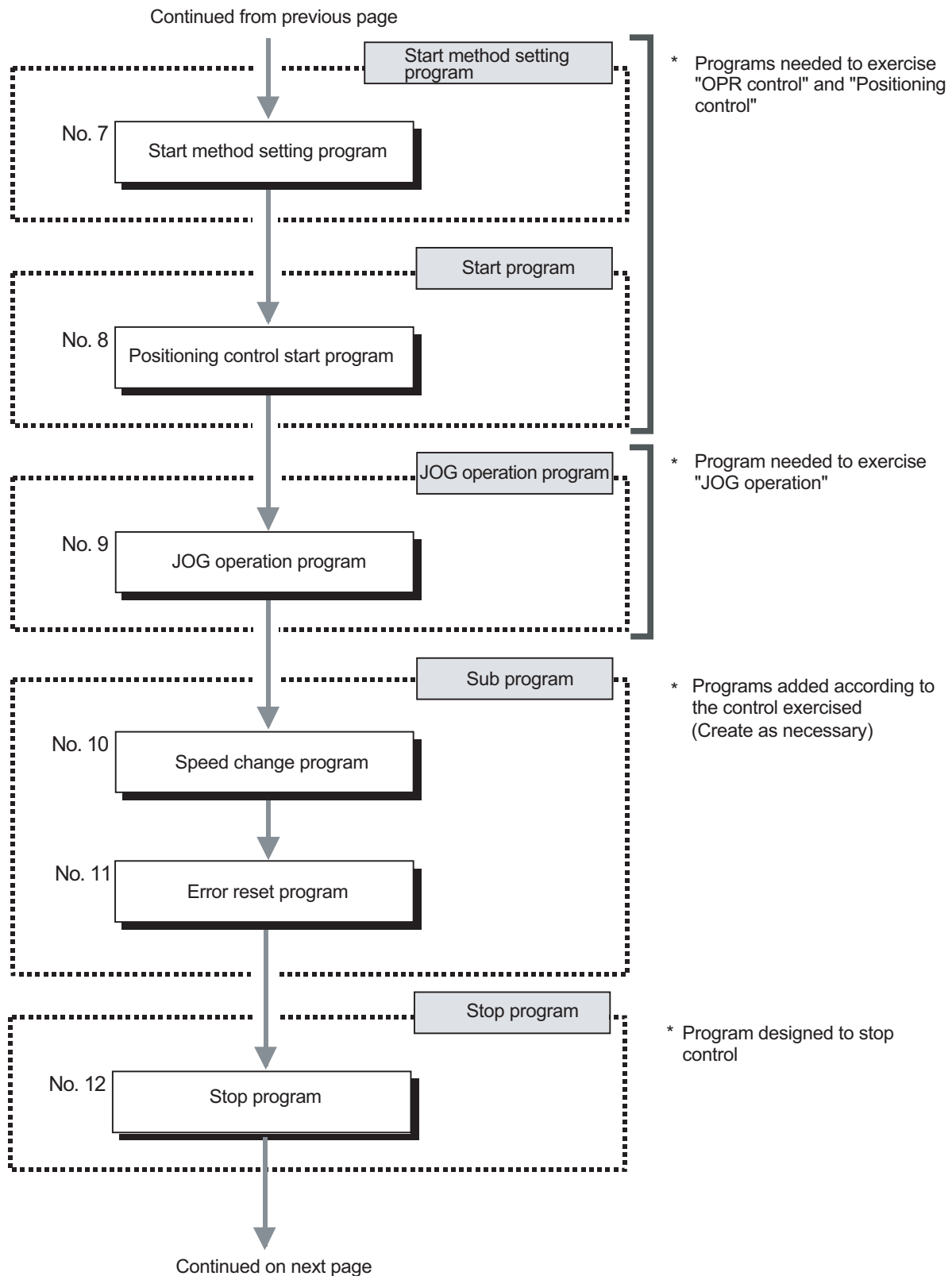

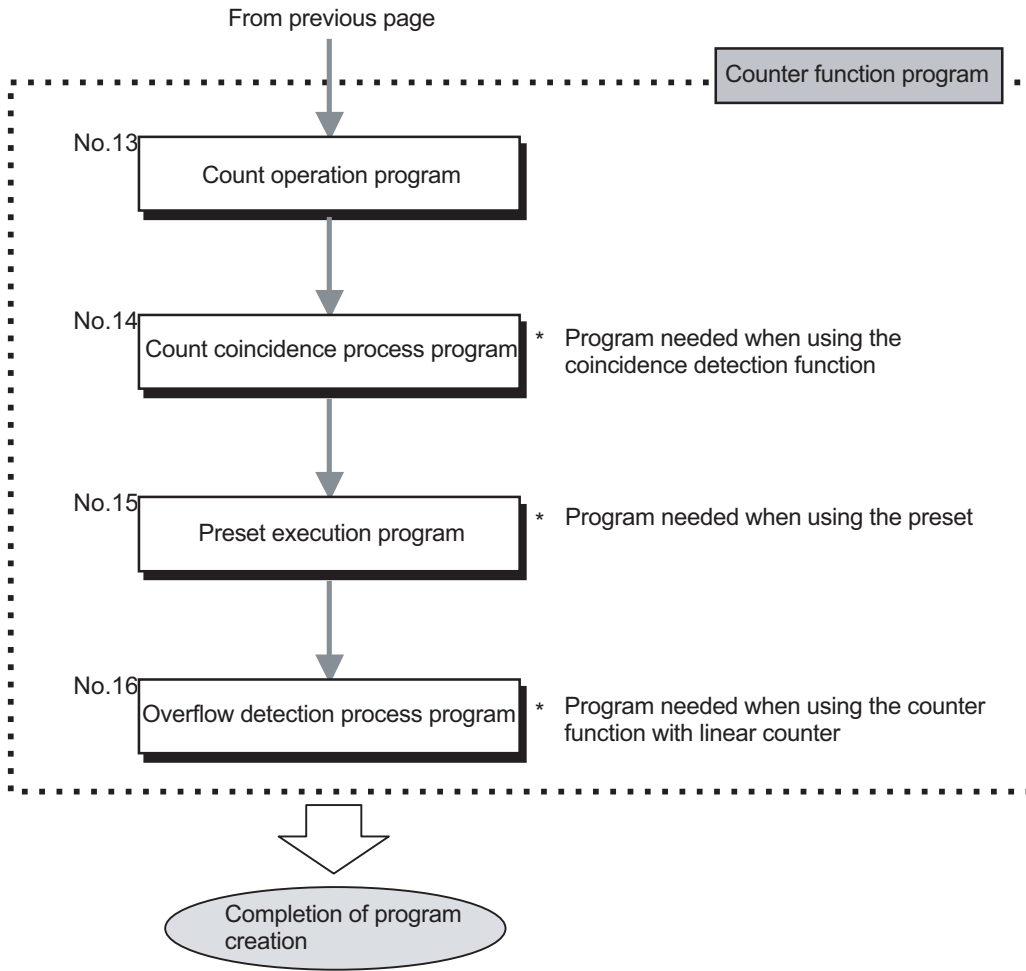

7.4 Positioning Control Program Examples

This section describes the examples of positioning control program for "Axis 1".

- [No.1] to [No.4] parameter and data setting program -----
- When setting the parameters or data with the sequence program, set them in the QD72P3C3 using the TO instruction from the programmable controller CPU. (Carry out the setting while the programmable controller CPU READY signal (Y0) is OFF.)
 - When setting the parameters or data with GX Configurator-PT, programs for [No.1] to [No.4] are not necessary.

No.1 Positioning parameter setting program

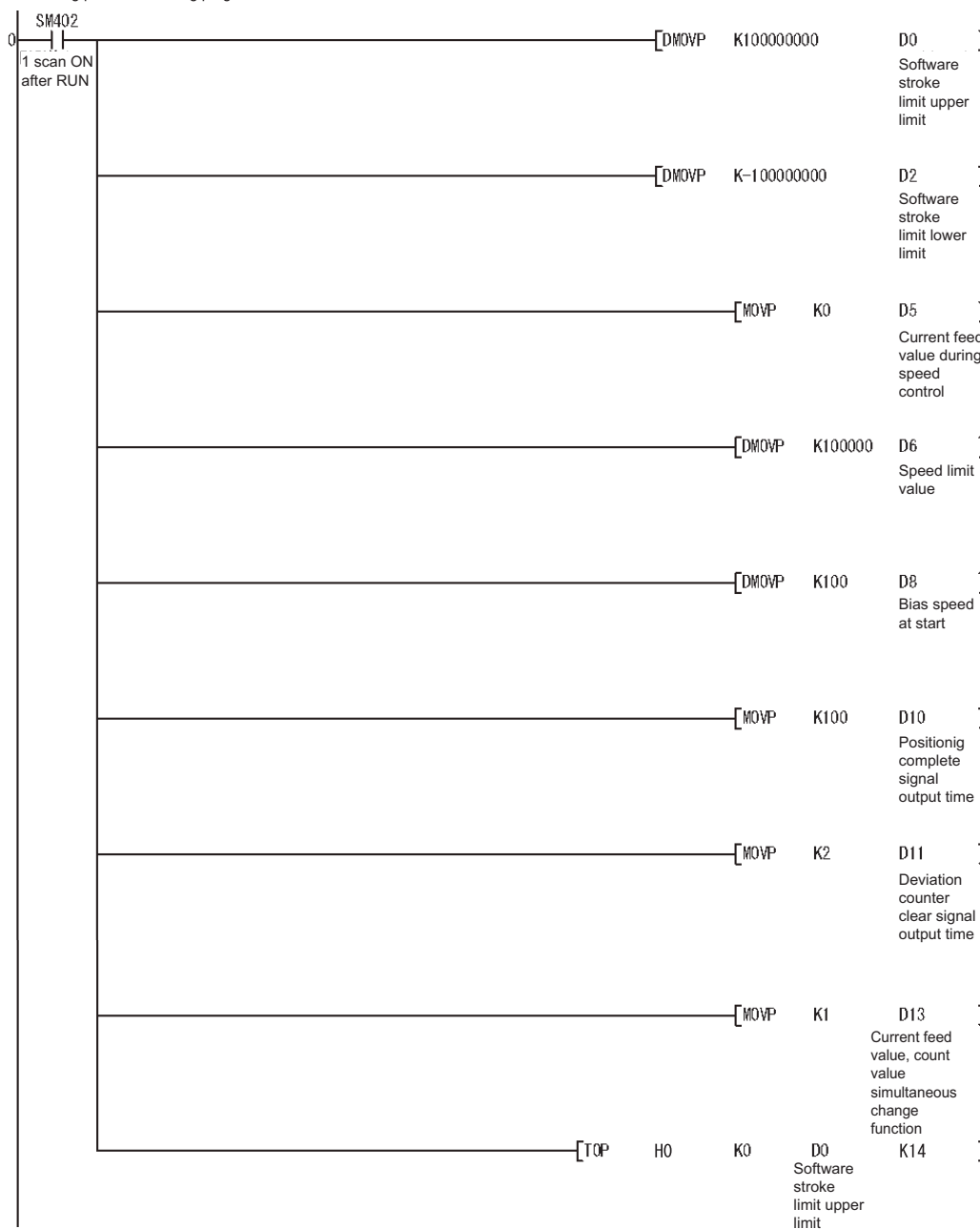

7

SEQUENCE PROGRAM USED FOR POSITIONING CONTROL

No.3 Counter parameter, data setting program

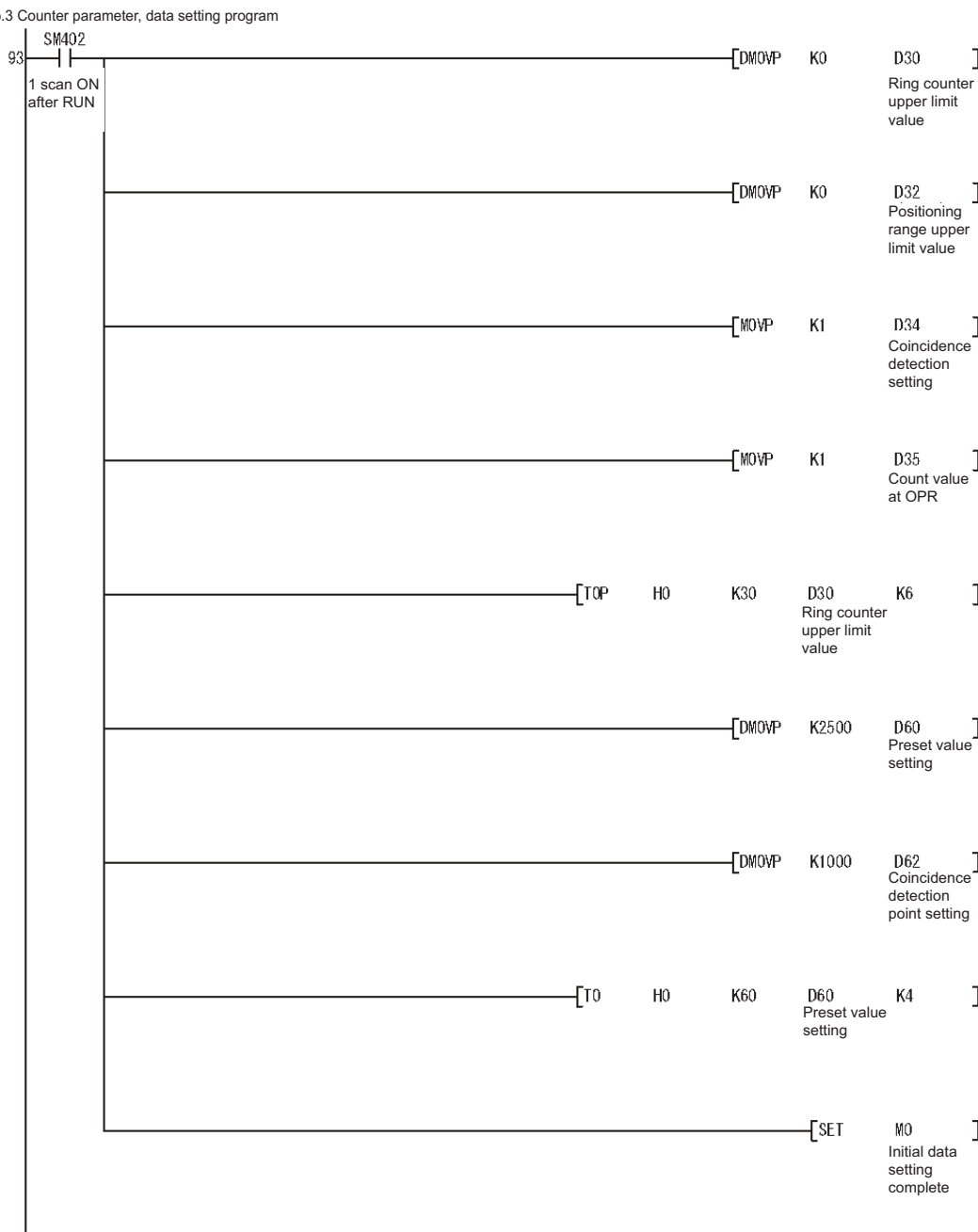

7

SEQUENCE PROGRAM USED FOR POSITIONING CONTROL

No.4 Positioning data setting program
(1) 1-axis linear control setting

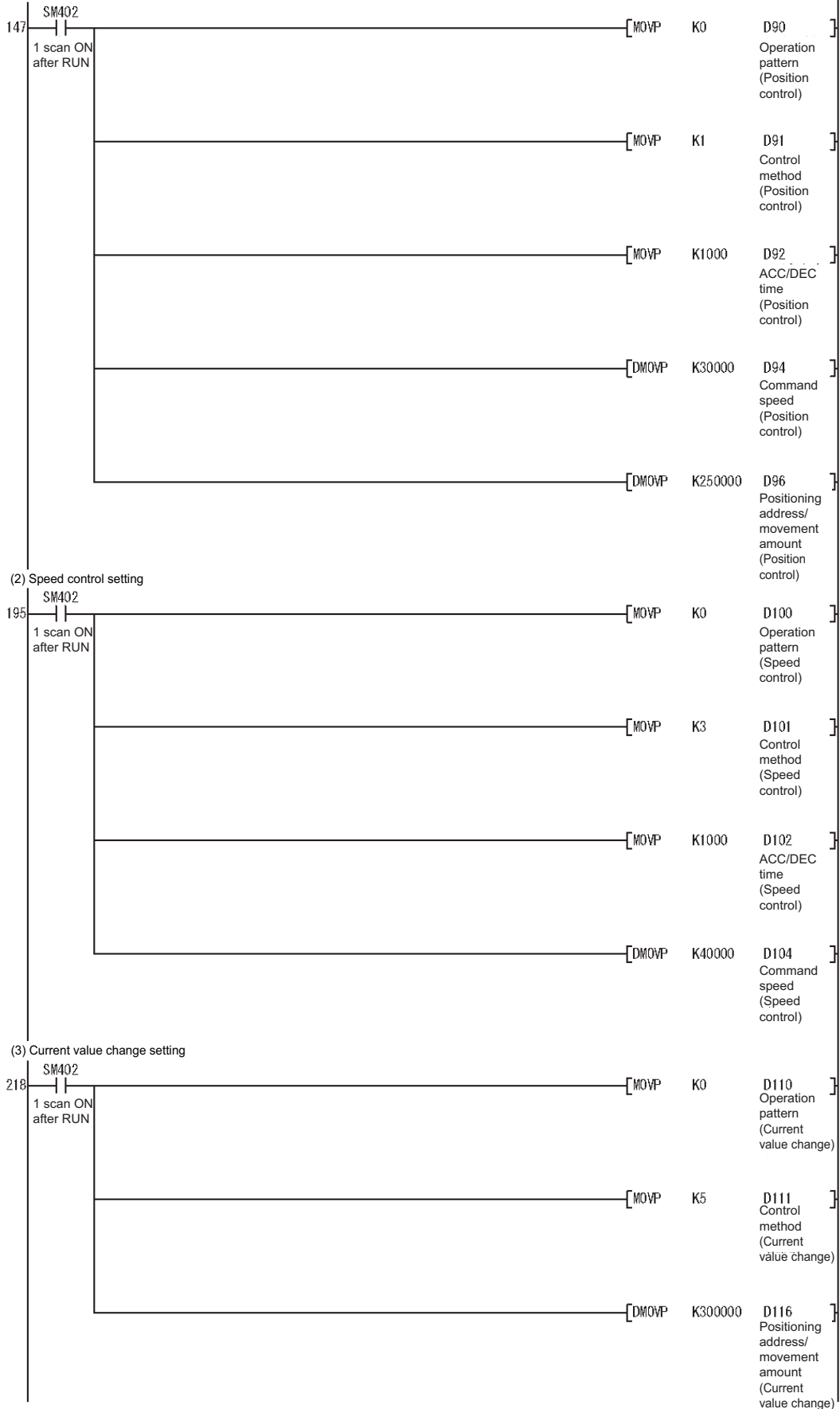

1
PRODUCT OUTLINE

2
SYSTEM CONFIGURATION

3
SPECIFICATIONS AND FUNCTIONS

4
DATA USED FOR POSITIONING CONTROL

5
PROCEDURES AND SETTINGS BEFORE OPERATION

6
UTILITY PACKAGE (GX Configurator-PT)

7
SEQUENCE PROGRAM USED FOR POSITIONING

8
OPR CONTROL

7

SEQUENCE PROGRAM USED FOR POSITIONING CONTROL

No.5 Programmable controller CPU READY signal [Y0] ON program

(MO contact is not needed when GX Configurator-PT is used to set the initial setting of parameters and data.)



No.6 OPR request OFF program

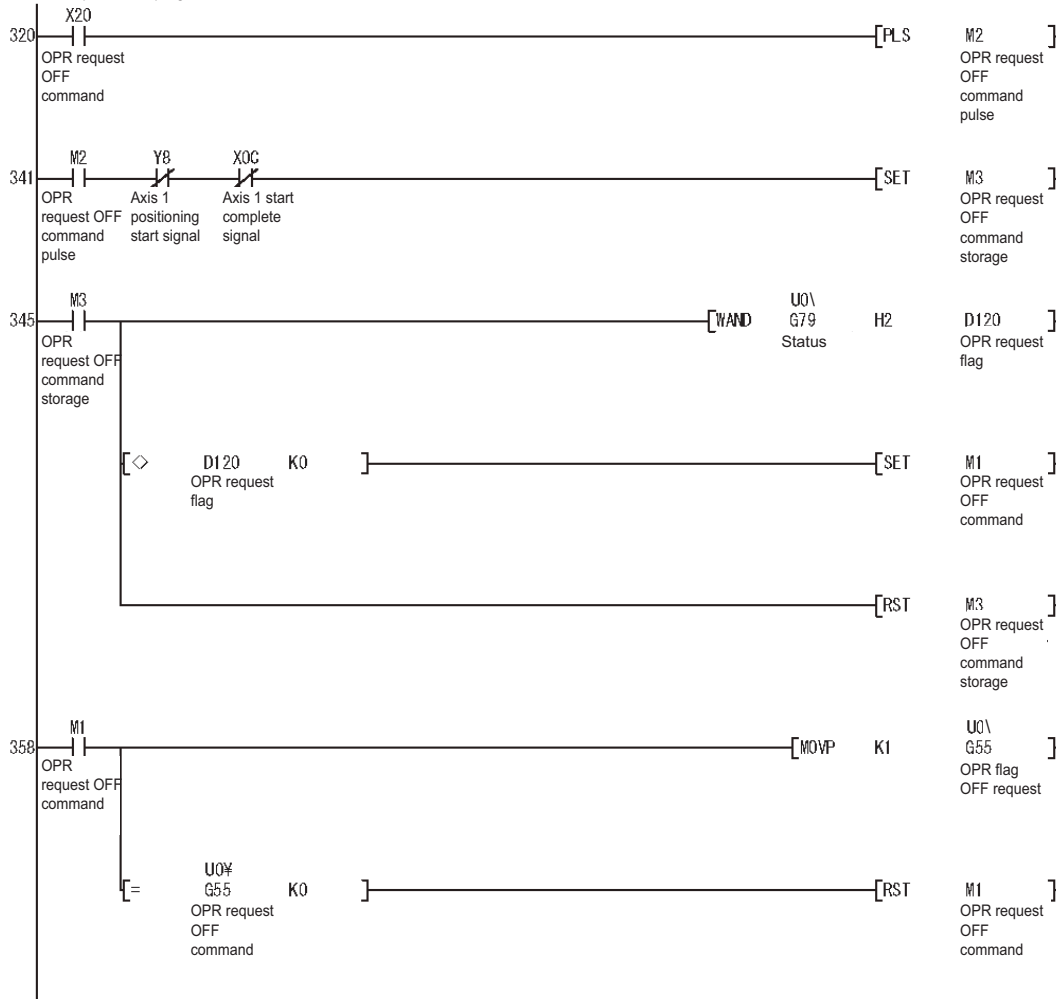

7

SEQUENCE PROGRAM USED FOR POSITIONING CONTROL

No.7 Start pattern setting program

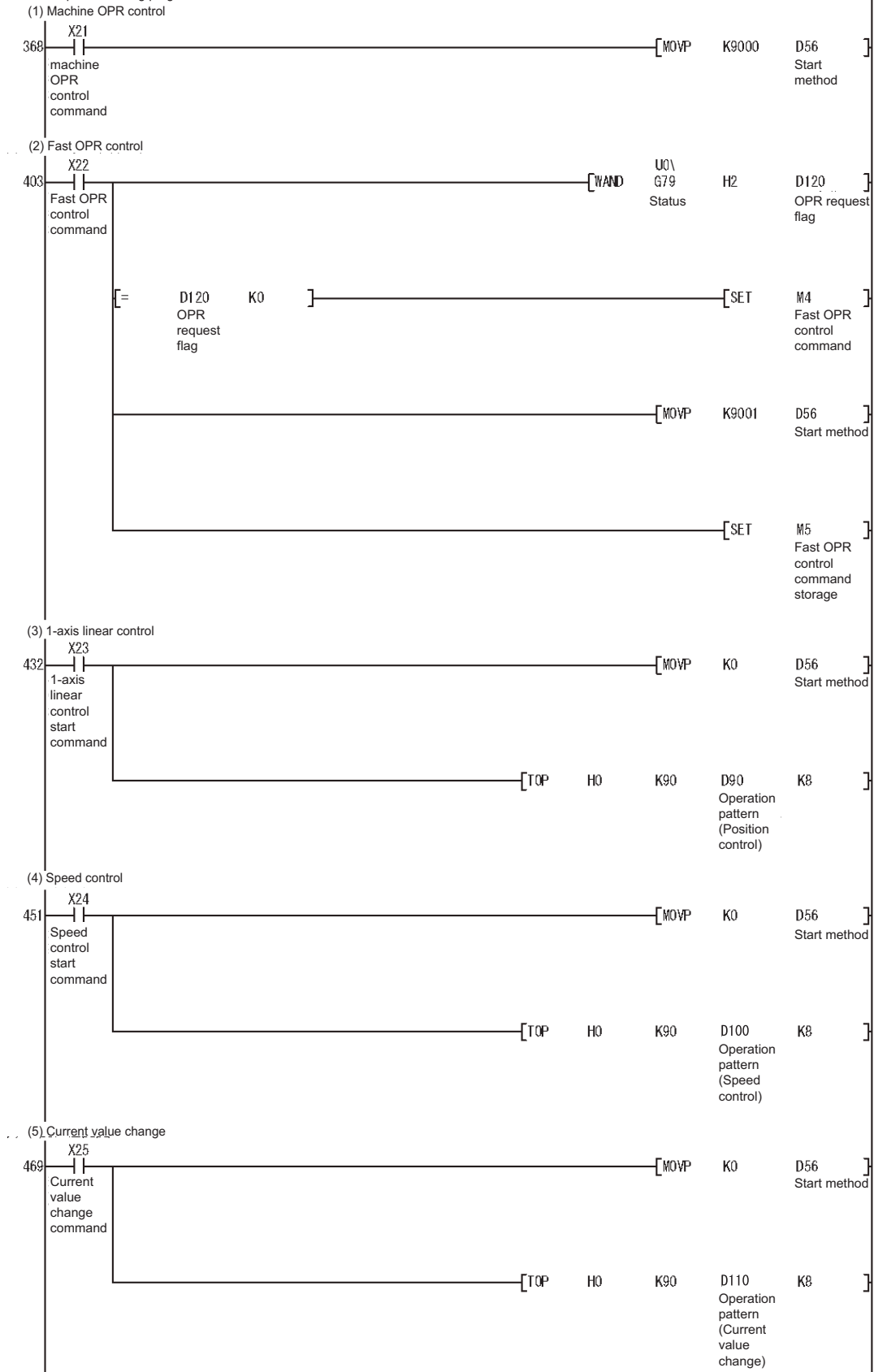

1
PRODUCT OUTLINE

2
SYSTEM CONFIGURATION

3
SPECIFICATIONS AND FUNCTIONS

4
DATA USED FOR POSITIONING CONTROL

5
PROCEDURES AND SETTINGS BEFORE OPERATION

6
UTILITY PACKAGE (GX Configurator-PT)

7
SEQUENCE PROGRAM USED FOR POSITIONING

8
OPR CONTROL

7

SEQUENCE PROGRAM USED FOR POSITIONING CONTROL

(6) Turning OFF fast OPR control command and fast OPR control command storage
(When not using fast OPR)

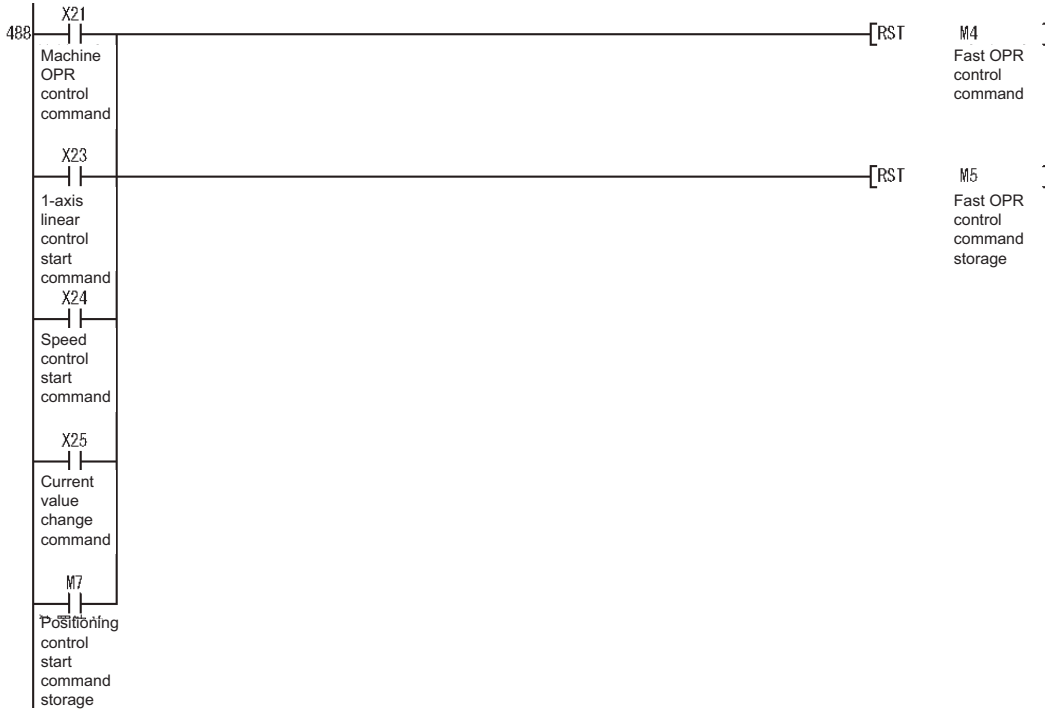

No.8 Positioning control start program

(M4 and M5 contacts are not needed when fast OPR control is not carried out.)
(M8 contact is not needed when JOG operation is not carried out.)

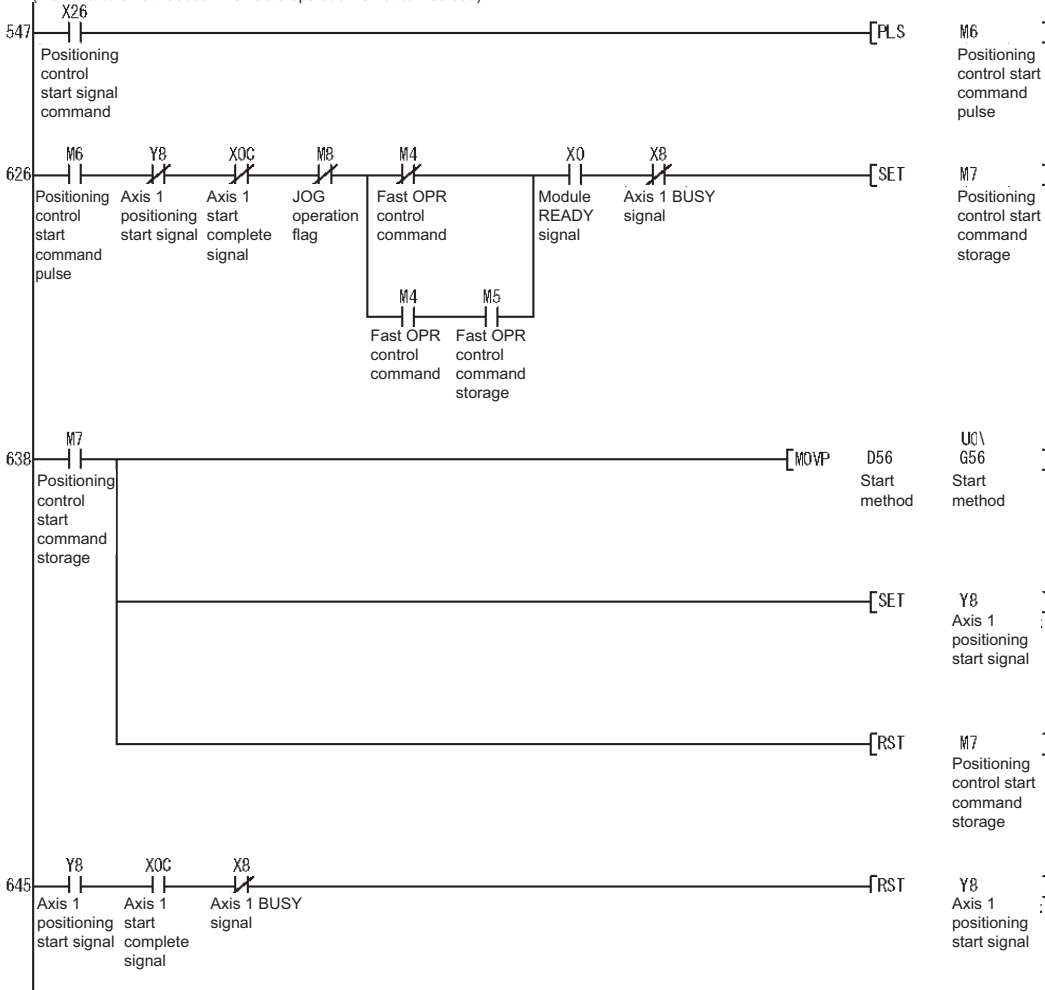

7

SEQUENCE PROGRAM USED FOR POSITIONING CONTROL

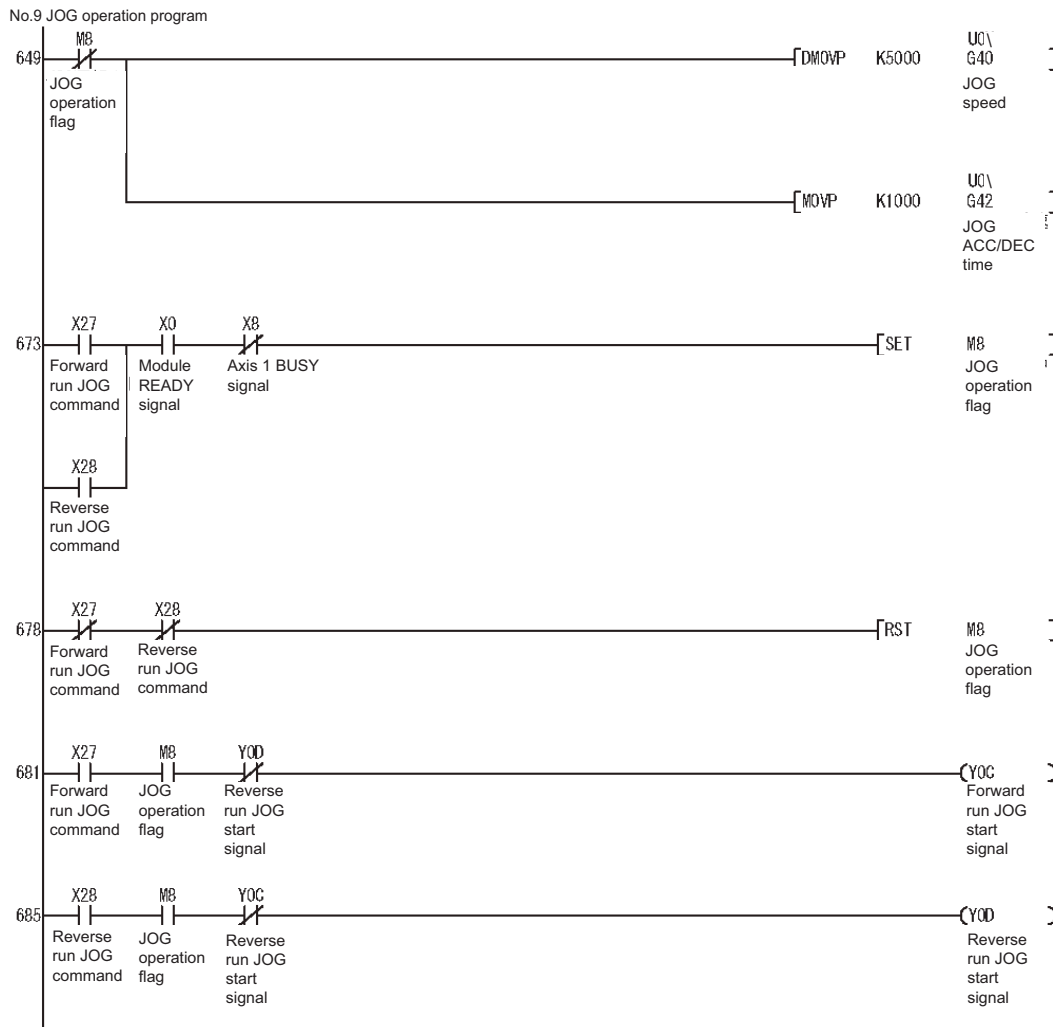

1
PRODUCT OUTLINE

2
SYSTEM CONFIGURATION

3
SPECIFICATIONS AND FUNCTIONS

4
DATA USED FOR POSITIONING CONTROL

5
PROCEDURES AND SETTINGS BEFORE OPERATION

6
UTILITY PACKAGE (GX Configurator-PT)

7
SEQUENCE PROGRAM USED FOR POSITIONING

8
OPR CONTROL

7

SEQUENCE PROGRAM USED FOR POSITIONING CONTROL

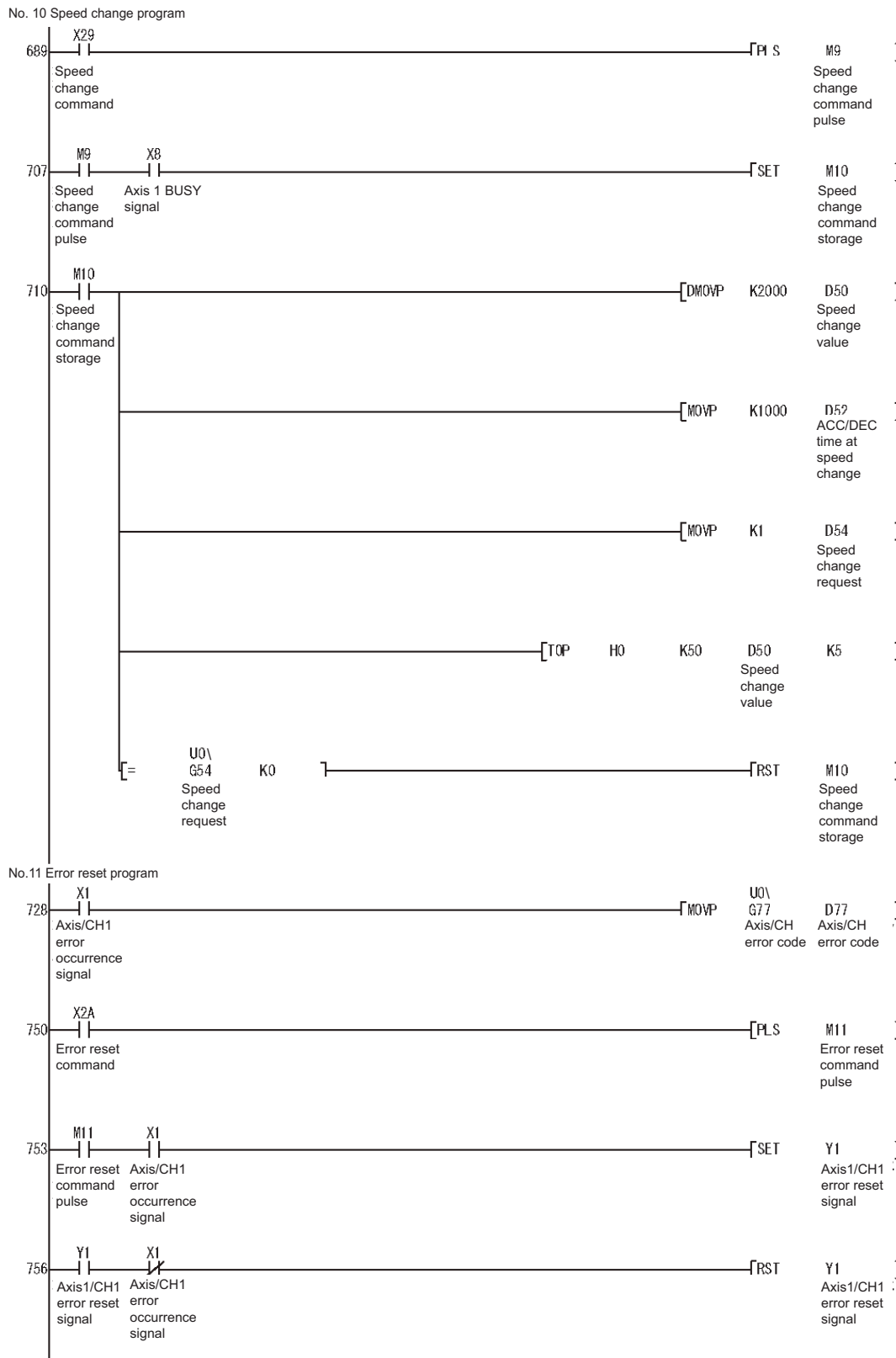

7

SEQUENCE PROGRAM USED FOR POSITIONING CONTROL

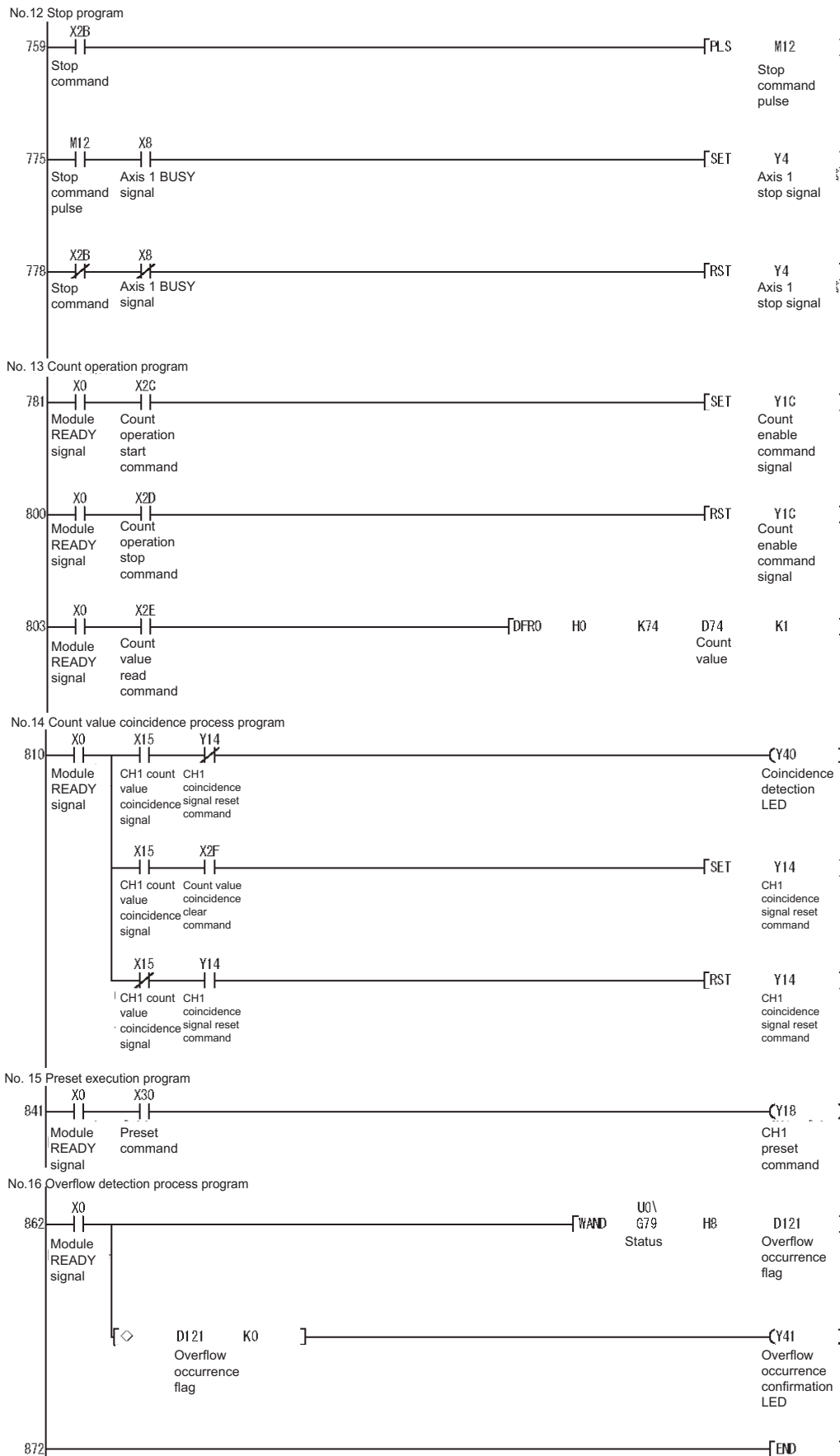

1 PRODUCT OUTLINE

2 SYSTEM CONFIGURATION

3 SPECIFICATIONS AND FUNCTIONS

4 DATA USED FOR POSITIONING CONTROL

5 PROCEDURES AND SETTINGS BEFORE OPERATION

6 UTILITY PACKAGE (GX Configurator-PT)

7 SEQUENCE PROGRAM USED FOR POSITIONING

8 OPR CONTROL

7.5 Program Details

7.5.1 Initialization program

(1) OPR request OFF program

This program forcibly turns OFF the "OPR request flag" ([Md.7] Status: b1) which is ON.

When using a system that does not require OPR control, configure the program to cancel the "OPR request" executed by the QD72P3C3 at the power is turned ON.

■ Data requires setting

Set the following data to use the OPR request flag OFF request.

Setting item	Setting value	Buffer memory address		
		Axis 1	Axis 2	Axis 3
[Cd.4] OPR request flag OFF request	1: Turn OFF the OPR request flag	55	155	255

* For details of the setting contents, refer to "Section 4.6 Control Data List".

■ OPR OFF request timing chart

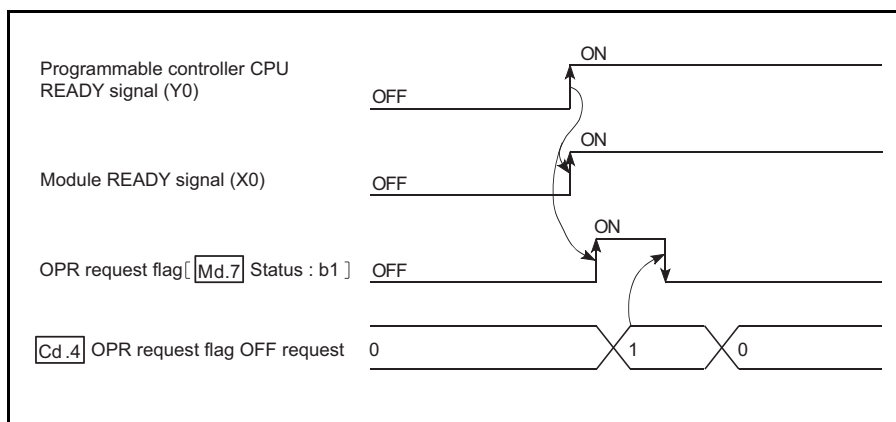

Figure 7.1 OPR OFF request timing chart

7.5.2 Start method setting program

This program is designed to set a control to be performed out of "OPR control" or "Positioning control".

■ Data requires setting

Set " Start method" according to the control to be started.

Setting item	Setting value	Buffer memory address		
		Axis 1	Axis 2	Axis 3
<input type="text" value="Cd.5"/> Start method	0: Positioning control			
	9000: Machine OPR control	56	156	256
	9001: Fast OPR control			

* For details of the setting contents, refer to "Section 4.6 Control Data List".

7.5.3 Start program

This program is designed to start OPR control or positioning control using the positioning start signal (Y8 to YA). (For details of OPR control and positioning control, refer to CHAPTER 8 and CHAPTER 9.)

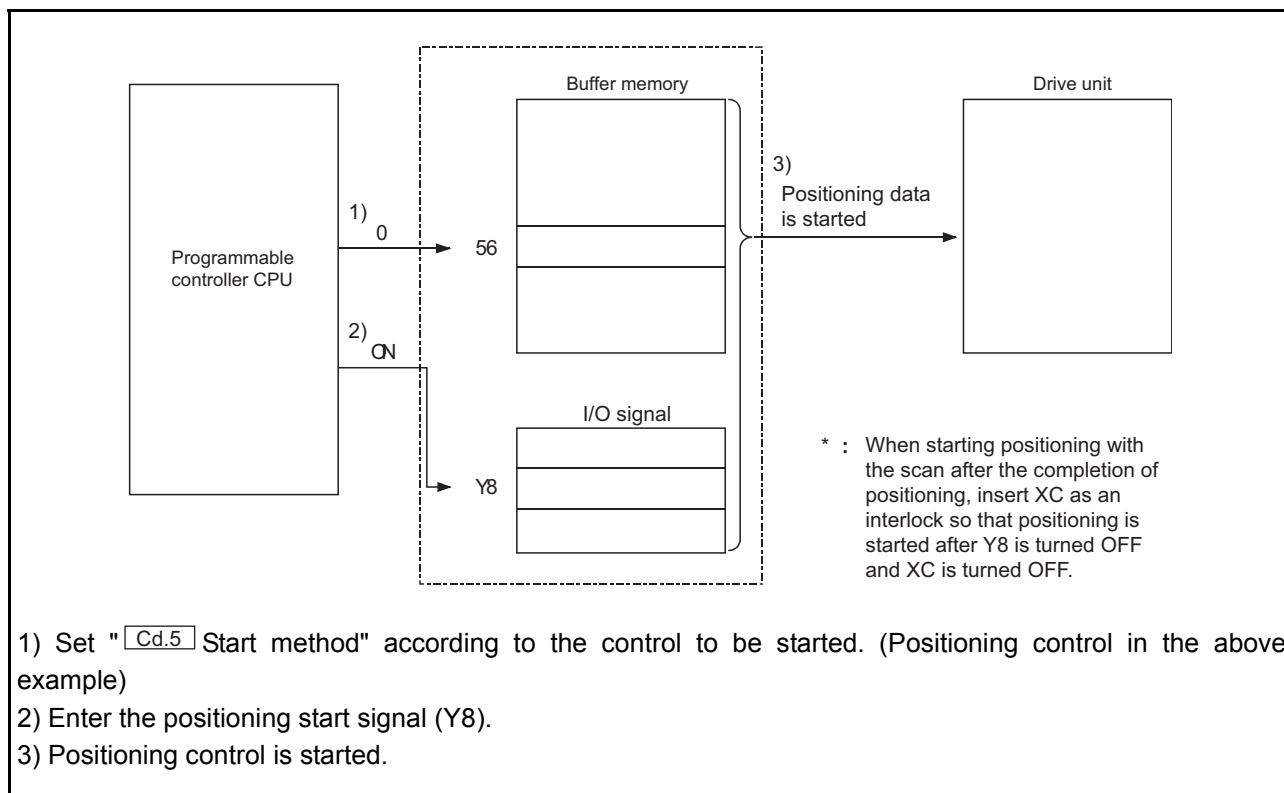

Figure 7.2 Procedures for starting control (for axis 1)

■ Starting condition

To start the control, the following conditions must be satisfied.

In addition, the necessary conditions must be incorporated in the sequence program so that the control does not start when the conditions are not satisfied.

Signal name	Signal status	Device		
		Axis 1	Axis 2	Axis 3
Programmable controller CPU READY signal	ON	Programmable controller CPU prepared		
Module READY signal	ON	QD72P3C3 prepared		
Axis/CH error occurrence signal	OFF	No error		
Axis stop signal	OFF	Y4	Y5	Y6
Start complete signal	OFF	XC	XD	XE
BUSY signal	OFF	X8	X9	XA

■ Operation when starting

- (1) When the positioning start signal (Y8 to YA) is turned ON, the start complete signal (XC to XE) and BUSY signal (X8 to XA) turn ON, and the OPR control or positioning control starts. It can be seen that the axis is operating when the BUSY signal is ON.
- (2) When the positioning start signal (Y8 to YA) is turned OFF, the start complete signal (XC to XE) also turns OFF. When the positioning start signal (Y8 to YA) remains ON even after OPR control or positioning control is completed, the start complete signal (XC to XE) remains ON.
- (3) If the positioning start signal (Y8 to YA) is turned ON again while the BUSY signal (X8 to XA) is ON, "Start during operation" warning (warning code: 10) occurs.
- (4) The process taken when positioning control is completed is as follows.
 - On completion of positioning control, the BUSY signal (X8 to XA) turns OFF and the positioning complete signal (X10 to X12) turns ON.
 - However, the signal does not turn ON when "Pr.6 Positioning complete signal output time" is 0.
 - After the "Pr.6 Positioning complete signal output time" has elapsed, the positioning complete signal (X10 to X12) turns OFF.

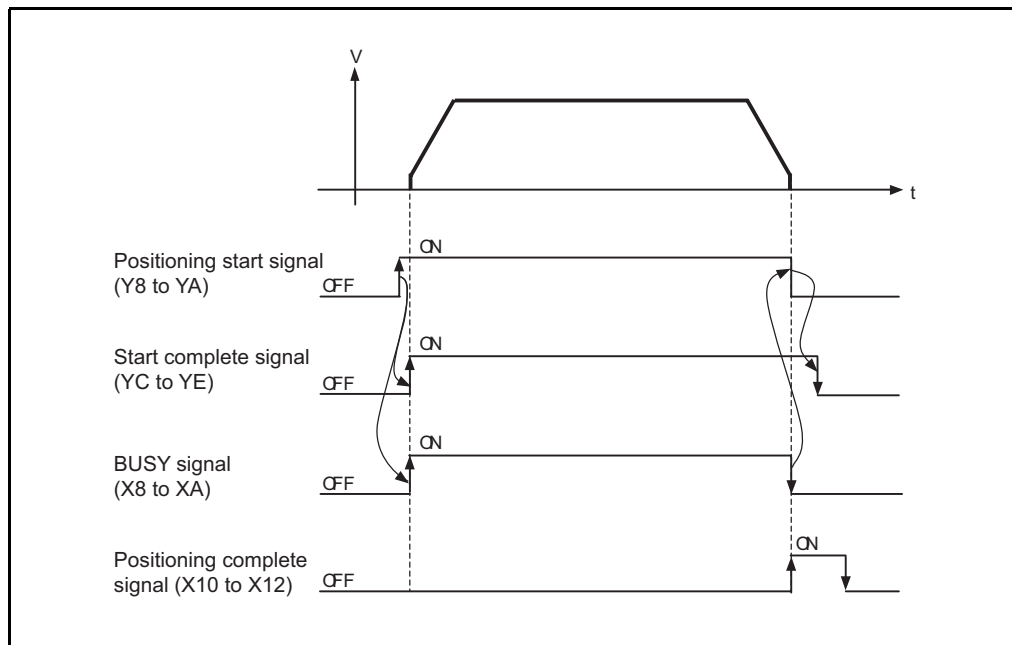

Figure 7.3 ON/OFF timing of each signal at the start of positioning control

POINT

The BUSY signal (X8 to XA) turns ON even when position control of movement amount 0 is performed. However, since the ON time is short, the ON status may not be detected in the sequence program. (The ON status of the start complete signal (XC to XE) and the positioning complete signal (X10 to X12) can be detected in the sequence program.)

start timing chart

The timing charts for starting each control are shown below.

(5) Machine OPR control start timing chart

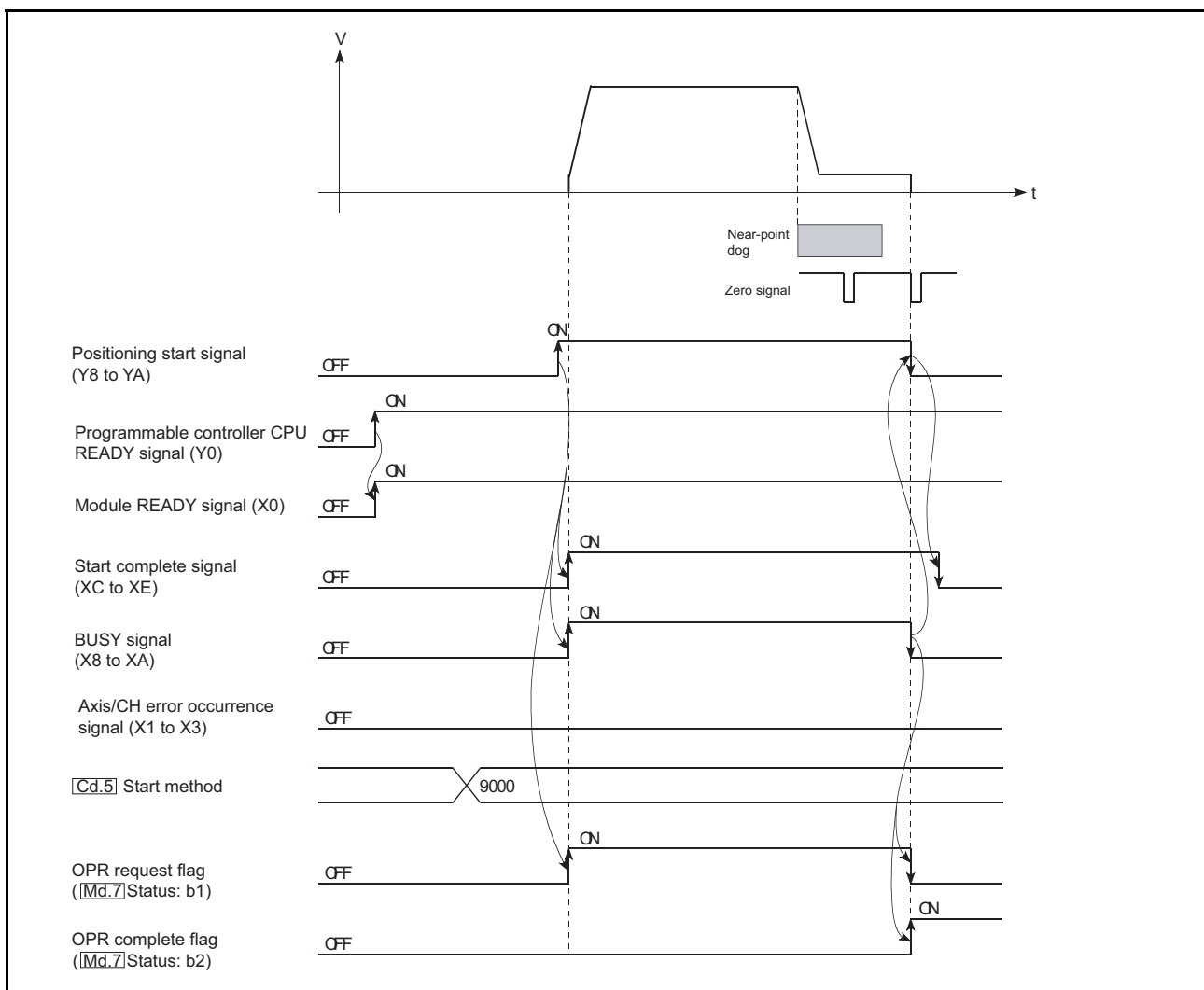

Figure 7.4 Machine OPR control start timing chart

(6) Fast OPR control start timing chart

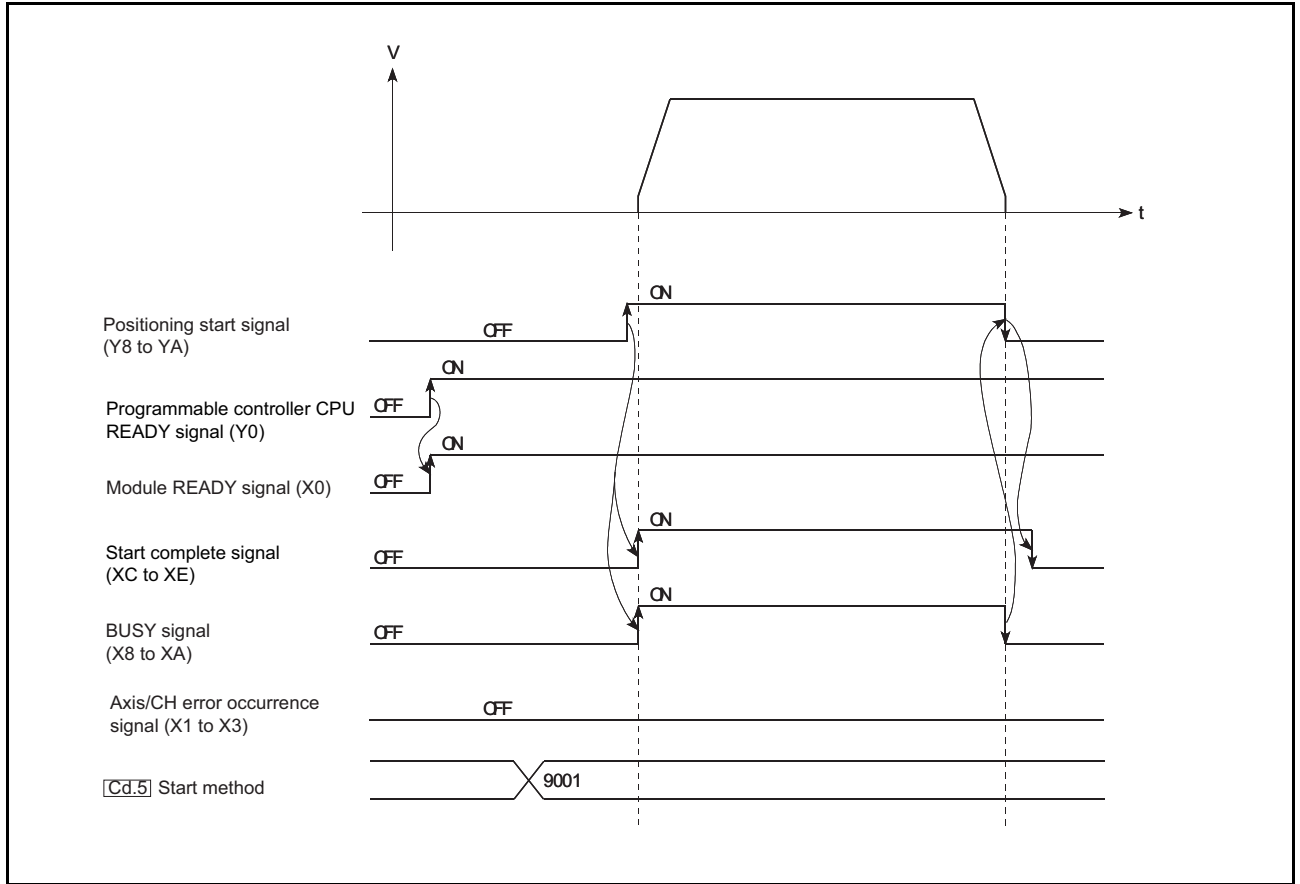

Figure 7.5 Fast OPR control start timing chart

(7) Positioning control start timing chart

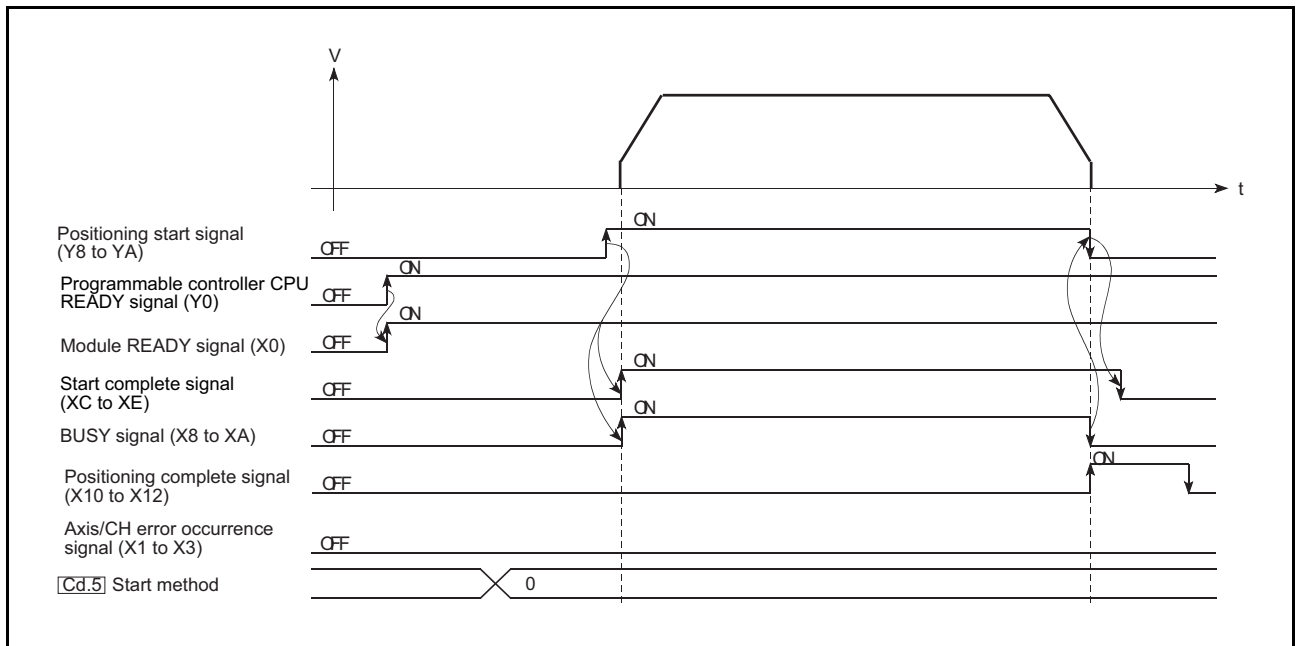

Figure 7.6 Positioning control start timing chart

☒ POINT

For positioning control and OPR control, multiple axes can be started simultaneously. In this case, turn ON the positioning start signal (Y8 to YA) of the target axes within the same scan.

(However, after multiple axes have been started simultaneously, they cannot be stopped simultaneously.)

7.5.4 Auxiliary program

Speed change program

This program is used to change the speed within "[Pr.4] Speed limit value" range during the constant speed of the speed control and JOG operation.

Set the new speed in "[Cd.1] New speed value". The speed is changed according to "[Cd.3] Speed change request".

The ACC/DEC time when the speed is changed is the value set in "[Cd.2] ACC/DEC time at speed change".

(For details of the speed change function, refer to "Section 11.3 Speed Change Function".)

■ Data requires setting

Set the following data.

Setting item	Setting value	Buffer memory address		
		Axis 1	Axis 2	Axis 3
		1	2	3
[Cd.1] New speed value	2000pulse/s	50 51	150 151	250 251
[Cd.2] ACC/DEC time at speed change	1000ms	52	152	252
[Cd.3] Speed change request	1: Speed change requested	54	154	254

* For details of the setting contents, refer to "Section 4.6 Control Data List".

■ Speed changing timing chart

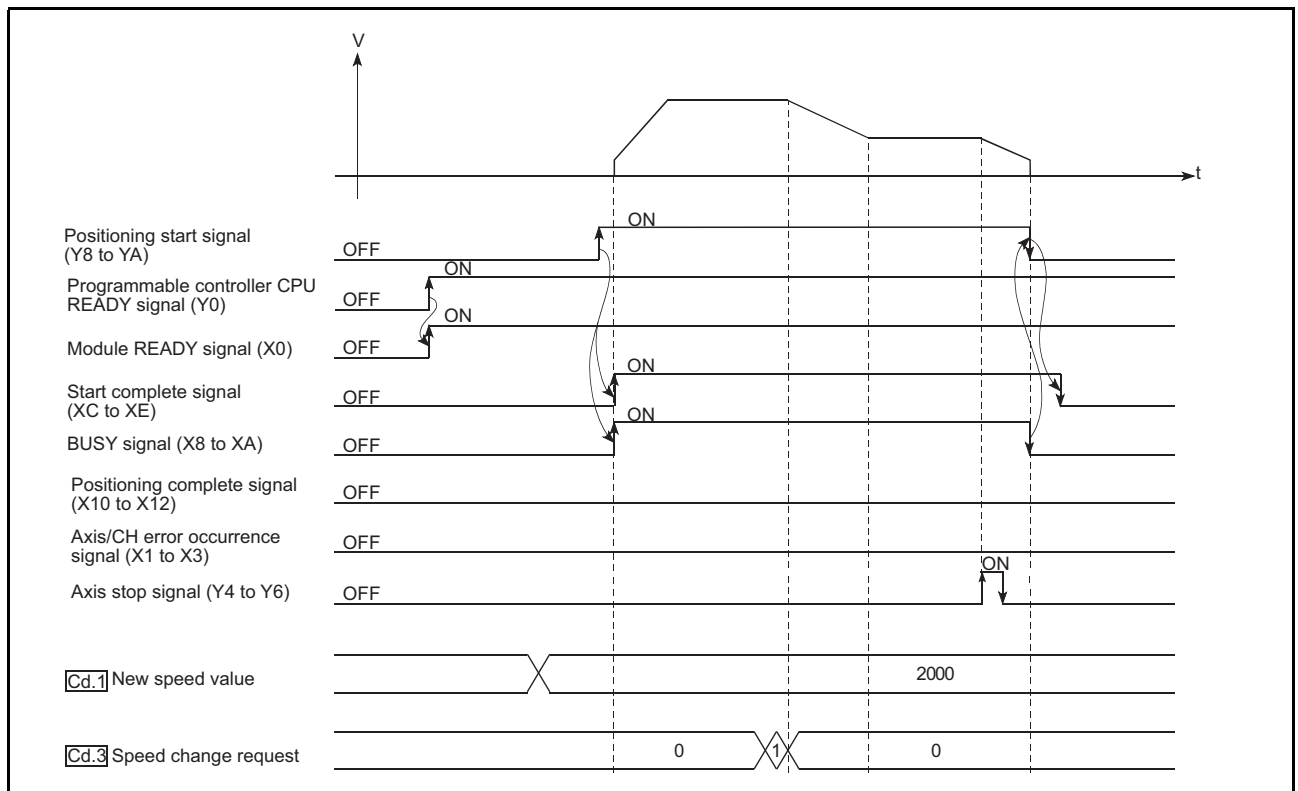

Figure 7.7 Speed changing timing chart

PART 2 CONTROL DETAILS AND SETTING

PART 2 consists for the following purposes (1) to (3).

- (1) To Understand the operation and restrictions of each control
- (2) To perform the required settings in each control
- (3) To deal with errors

The required settings in each control include parameter setting, positioning data setting, and control data setting by the sequence program.

Make the settings while referring to "CHAPTER 4 DATA USED FOR POSITIONING CONTROL".

In addition, when creating a sequence program required for each control, refer to "CHAPTER 7 SEQUENCE PROGRAM USED FOR POSITIONING CONTROL" and consider the entire control program configuration.

CHAPTER1	PRODUCT OUTLINE	1 - 1 to 1 -
CHAPTER2	SYSTEM CONFIGURATION	2 - 1 to 2 -
CHAPTER3	SPECIFICATIONS AND FUNCTIONS	3 - 1 to 3 -
CHAPTER4	DATA USED FOR POSITIONING CONTROL	4 - 1 to 4 -
CHAPTER5	PROCEDURES AND SETTINGS BEFORE OPERATION	5 - 1 to 5 -
CHAPTER6	UTILITY PACKAGE (GX Configurator-PT)	6 - 1 to 6 -
CHAPTER7	SEQUENCE PROGRAM USED FOR POSITIONING CONTROL	7 - 1 to 7 -
CHAPTER8	OPR CONTROL	8 - 1 to 8 -
CHAPTER9	POSITIONING CONTROL	9 - 1 to 9 -
CHAPTER10	JOG OPERATION	10 - 1 to 10 -
CHAPTER11	AUXILIARY FUNCTION	11 - 1 to 11 -
CHAPTER12	COUNTER FUNCTION	12 - 1 to 12 -
CHAPTER13	COMMON FUNCTION	13 - 1 to 13 -
CHAPTER14	DEDICATED INSTRUCTIONS	14 - 1 to 14 -
CHAPTER15	TROUBLESHOOTING	15 - 1 to 15 -

CHAPTER8 OPR CONTROL

This chapter describes details of the QD72P3C3 OPR control.

8.1 Outline of OPR Control

8.1.1 Two types of OPR control

"OPR control" is control to establish a position (=OP) which is to be a reference when performing positioning control.

This control is used to return a mechanical system at any position other than the OP to the OP when the QD72P3C3 issues "OPR request*" such as at power-ON or after positioning control stop.

The QD72P3C3 defines the following two control types as "OPR control" in the sequence of OPR operation.

These OPR controls can be performed by setting "OPR parameter", "9000" or "9001" to "[Cd.5] Start method", and turning ON the positioning start signal (Y8 to YA).

Establishing a positioning control OP	"Machine OPR control" ([Cd.5] Start method: 9000)
Performing position control toward the OP	"Fast OPR control" ([Cd.5] Start method: 9001)

* "Machine OPR control" must be performed before performing "fast OPR control".

■ When OPR control is not needed

In the system that does not require OPR control, setting "1" to "[Cd.4] OPR request flag OFF request" forcibly turns OFF "OPR request flag" ([Md.7] Status: b1).

When OPR control is not performed, operation starts using the position at power-ON ([Md.1] Current feed value) as "0".

* Also, the "OPR parameter" ([Pr.10] to [Pr.15]) must all be set to the default values or the values that will not result in an error.

Remark

OPR request*

In the following cases, the QD72P3C3 is required to turn ON "OPR request flag" ([Md.7] Status: b1) and perform machine OPR control.

- At power-ON
- At machine OPR control start

The "OPR request flag" turns OFF and the "OPR complete flag" ([Md.7] Status: b2) turns ON when the machine OPR control is performed and is completed normally.

8.2 Machine OPR Control

8.2.1 Outline of the machine OPR operation

❗IMPORTANT

- (1) Always set the OP in the same direction as viewed from any position in the workpiece moving area (set the OP near the upper or lower limit of the machine).
- (2) Correctly set the OPR direction so that it can be the same direction with the workpiece traveling direction to the OP.
- (3) When the following two conditions are satisfied, the axis continues operating at the OPR speed since near-point dog is not detected at machine OPR control start.
 - Machine OPR control is started at the position where the near-point dog is OFF.
 - The near-point dog does not exist in the OPR direction as seen from the machine OPR control start position.

In this case, perform JOG operation to move the axis to the position where the near-point dog exists in the OPR direction and the near-point dog is OFF.

(For details of JOG operation, refer to Chapter 10.)

■ Machine OPR control operation

In machine OPR control, near-point dog and zero signal are used to establish a machine OP.

None of the address information stored in the QD72P3C3, programmable controller CPU or drive unit is used at this time.

After the machine OPR control, mechanically established position is regarded as the "OP", reference for positioning control.

The method for establishing "OP" by a machine OPR control depends on "[Pr.10] OPR method".

The following describes the operation when starting machine OPR control.

1)	The machine OPR control is started.
2)	The operation starts according to the direction and speed set in the OPR parameter ([Pr.10] to [Pr.15]).
3)	The "OP" is established by the method set in "[Pr.10] OPR method", and the axis stops. (Refer to Section 8.2.3 and Section 8.2.4.)
4)	If "a" is set as "[Pr.12] OP address", "a" will be stored as the current position in the "[Md.1] Current feed value" which is monitoring the position.
5)	The machine OPR control is completed.

* For details of OPR parameter, refer to "Section 4.2 Parameter List".

"Pr.12 OP address" is a fixed value set by the user.

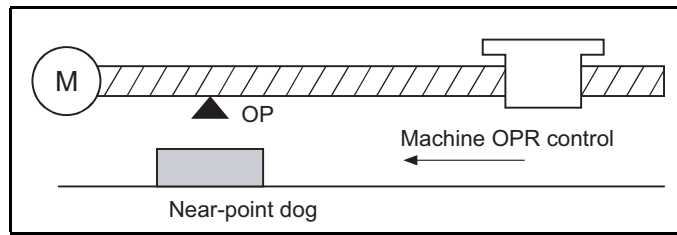

Figure 8.1 Example of a machine OPR control

8.2.2 OPR method for machine OPR control

This machine OPR control specifies a way to establish machine OP (method for judging the OP position and machine OPR control completion) according to configuration and application of the positioning control system.

The following table shows the two methods that can be used for this OPR method. (The OPR method is one of the items set in parameter. It is set to "[Pr.10] OPR method" in OPR parameter.)

[Pr.10] OPR method	Description
Near-point dog method	Deceleration starts when the near-point dog turns from OFF to ON. (The axis decelerates until it reaches at "[Pr.14] Creep speed".) The axis stops on detection of the first zero signal (signal output for one pulse per one rotation, e.g. Zero signal output from the drive unit) after the near-point dog turns from ON to OFF, and on completion of the deviation counter clear output, machine OPR control is completed.
Stopper 3	The stopper position is defined as the OP. The axis starts at "[Pr.14] Creep speed" from the beginning, and is brought into contact with the stopper to stop. After stop, when the deviation counter clear output is completed after zero signal (signal which detects that a workpiece contacts against a stopper, and then is output) detection, the machine OPR control is completed.

■ Wiring of signals required for each OPR method

I/O signal	OPR method	
	Near-point dog method	Stopper 3
Zero signal (PG0)	○	○
Near-point dog signal (DOG)	○	-
Deviation counter clear (CLEAR)	○	○

○: Wiring required - : Wiring not required

Remark

Creep speed

The speed is quite slow. The stopping accuracy is poor when the axis is suddenly stopped from high speed. Therefore, the axis must be switched to low speed. Set this speed to "[Pr.14] Creep speed".

8.2.3 OPR method (1): Near-point dog method

The following describes an operation outline of the OPR method "near-point dog method".

(1) Operation chart

1)	By turning ON the positioning start signal (Y8 to YA), machine OPR control is started. (Acceleration starts in the direction set in "[Pr.11] OPR direction" and at the time set in "[Pr.15] ACC/DEC time at OPR", and the axis moves at "[Pr.13] OPR speed".)
2)	Near-point dog ON is detected and deceleration starts at the time set in "[Pr.15] ACC/DEC time at OPR".
3)	The motor decelerates until it reaches to "[Pr.14] Creep speed", and then starts moving at the creep speed. (During deceleration, the near-point dog must be ON.)
4)	On detection of the first zero signal after near-point dog OFF, the pulse output from the QD72P3C3 stops immediately and the "deviation counter clear output" is output to the drive unit. (Set "deviation counter clear signal output time" to [Pr.7].)
5)	After the "deviation counter clear output" is output, the OPR complete flag ([Md.8] Status: b2) turns from OFF to ON and the OPR request flag ([Md.8] Status: b1) turns from ON to OFF.

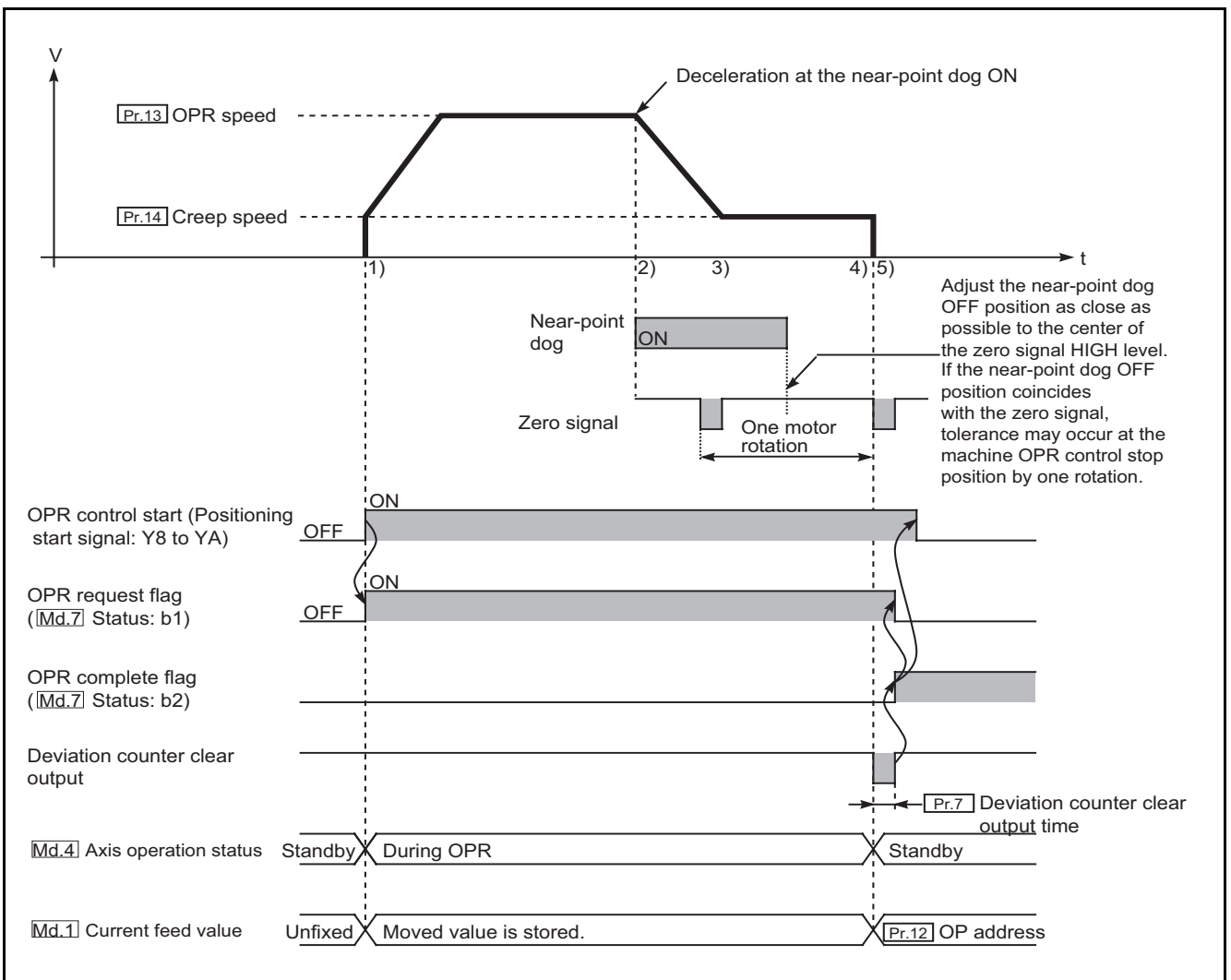

Figure 8.2 Machine OPR control in near-point dog method

(2) Restrictions

A pulse generator with a zero signal is required. When using a pulse generator without a zero signal, provide a zero signal outside.

(3) Precautions during operation

- (a) In OPR control, if a zero signal is ON when the near-point dog turns from ON to OFF, an error occurs.
- (b) If a zero signal is input while the near-point dog signal is OFF, an error "Zero signal ON (error code: 202)" occurs.
- (c) The near-point dog must be ON during deceleration from "[Pr.13] OPR speed" to "[Pr.14] Creep speed".
The following chart describes the operation when the near-point dog turns OFF before deceleration to "[Pr.14] Creep speed".

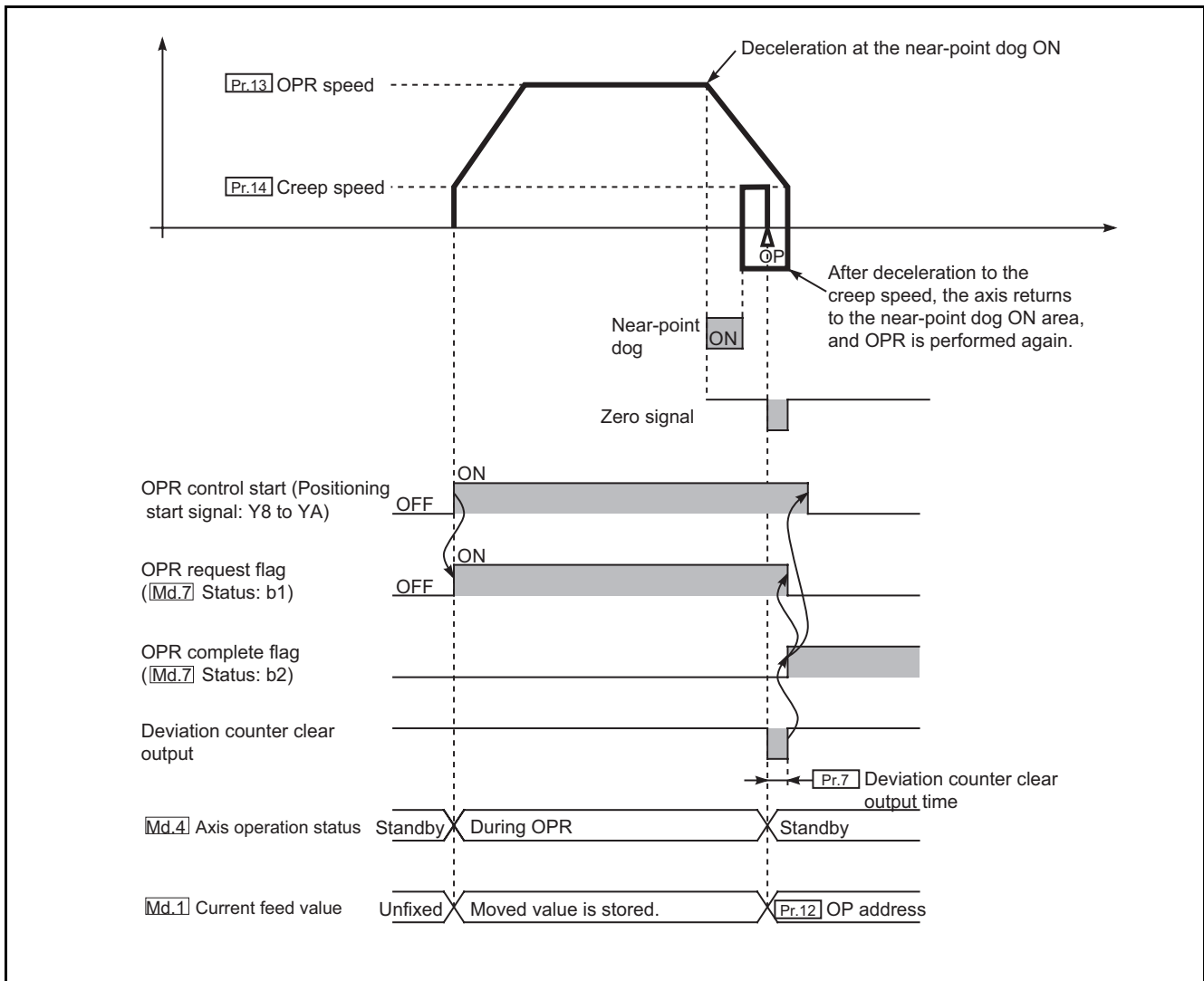

Figure 8.3 Operation when the near-point dog turns OFF before the axis reaches to the creep speed

(d) The following chart describes the operation when the near-point dog is OFF and no near-point dog exists in the OPR direction at the start of OPR control.

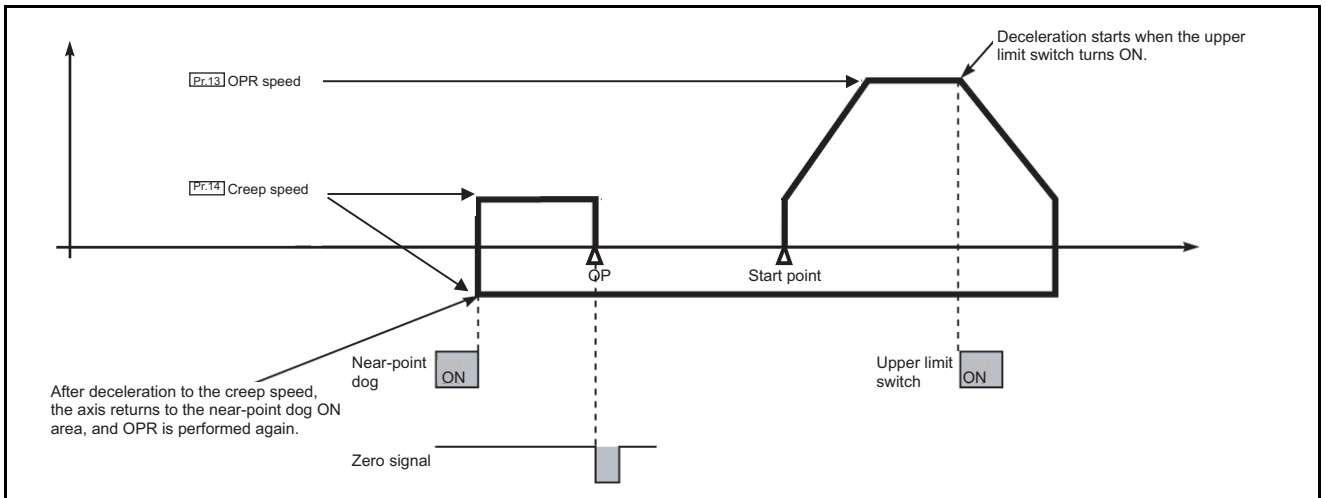

Figure 8.4 Operation when the near-point dog is OFF and no near-point dog exists in the OPR direction at the start of OPR control

(e) The following chart describes the operation when OPR is performed from ON position of the limit switch in the OPR direction at the start of OPR control.

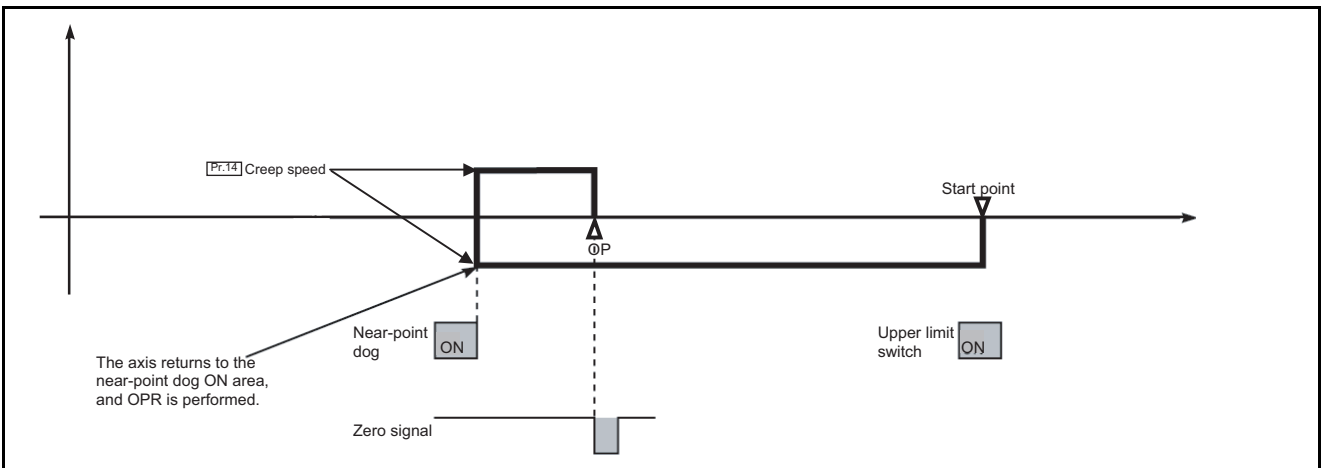

Figure 8.5 Operation when OPR is performed from ON position of the limit switch in the OPR direction at the start of OPR control

(f) The following chart describes the operation when OPR is performed from the near-point dog ON position.

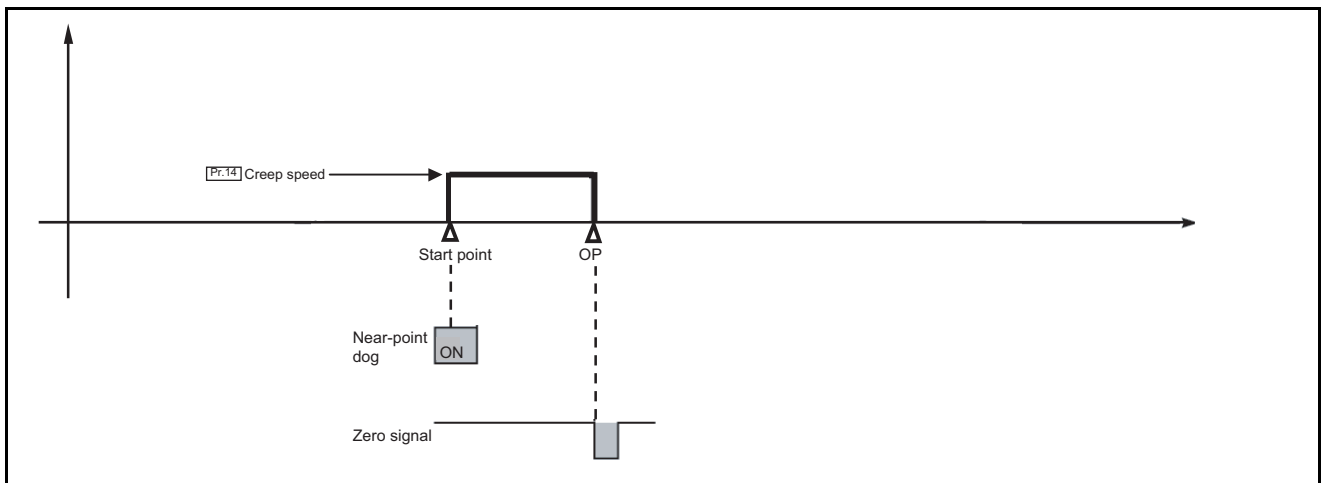

Figure 8.6 Operation when OPR is performed from the near-point dog ON position

8.2.4 OPR method (2): Stopper 3

The following describes an operation outline of the OPR method "stopper 3".
 The "stopper 3" is effective when a near-point dog cannot be installed. (Note that the axis operates at "[Pr.14] Creep speed" from the start. Therefore, it will take time to complete the machine OPR control.)

(1) Operation chart

1)	By turning ON the positioning start signal (Y8 to YA), machine OPR control is started. (The axis moves to the direction set in "[Pr.11] OPR direction" at "[Pr.14] Creep speed". At this time, a torque limit to the motor is required. If torque limit is not set, the motor may be a failure at 2).)
2)	The workpiece contacts against a stopper and stops.
3)	After the stop, the pulse output from the QD72P3C3 immediately stops on detection of a zero signal, and the "deviation counter clear output" is output to the drive unit. (Set "deviation counter clear signal output time" to [Pr.7].)
4)	After "deviation counter clear output" is output, the OPR complete flag ([Md.8] Status: b1) turns from OFF to ON and the OPR complete flag ([Md.8] Status: b0) turns from ON to OFF.

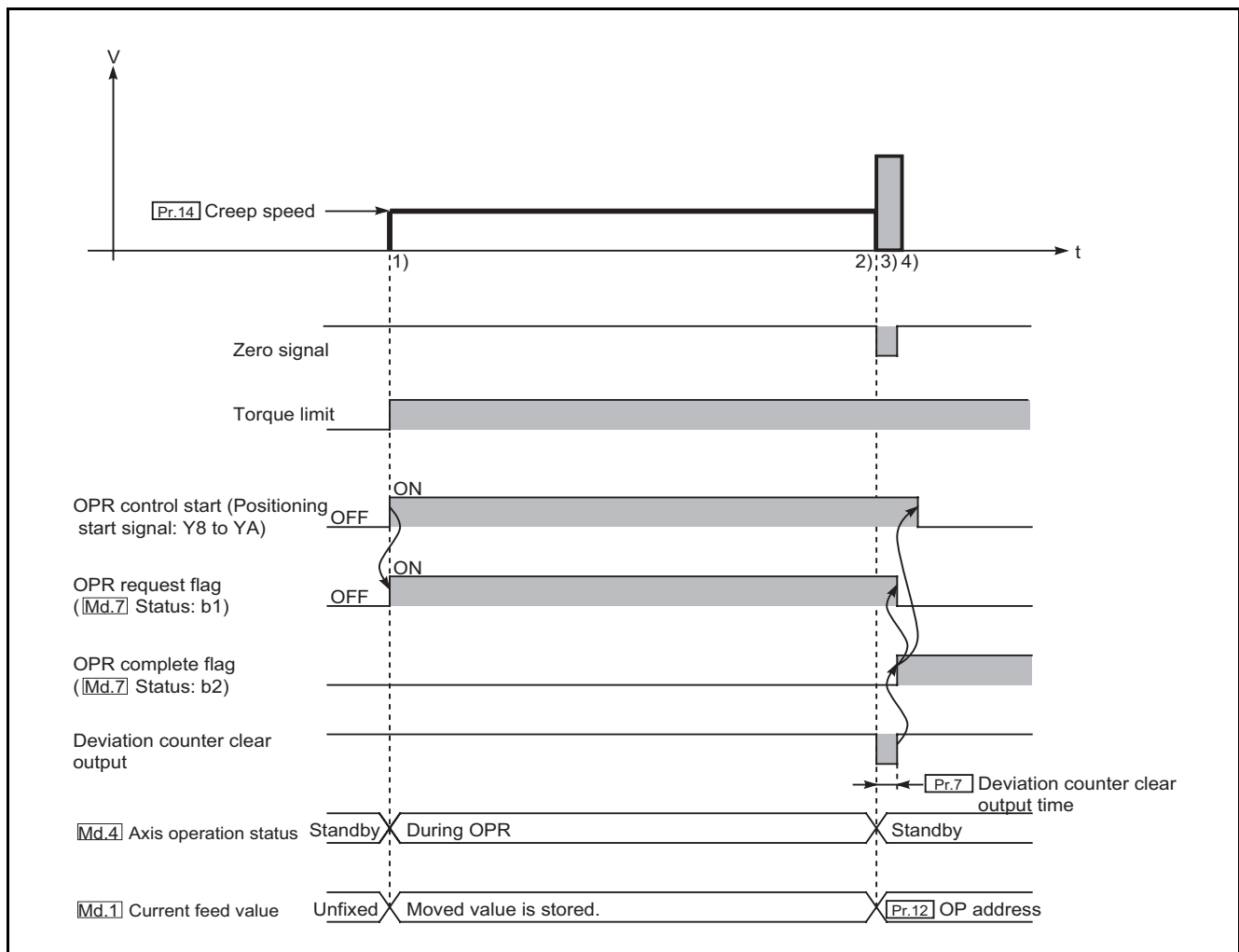

Figure 8.7 Stopper 3 machine OPR control

(2) Restrictions

- (a) Always set torque limit to the motor.
If the torque limit is not set, the motor may be a failure when the workpiece contacts against the stopper.
(For torque limit, refer to the manual for the drive unit.)
- (b) Use an external input signal as the zero signal.

(3) Precautions during operation

- (a) When the zero signal is input before the workpiece is stopped by the stopper, the workpiece stops, and the stop position will become the OP.

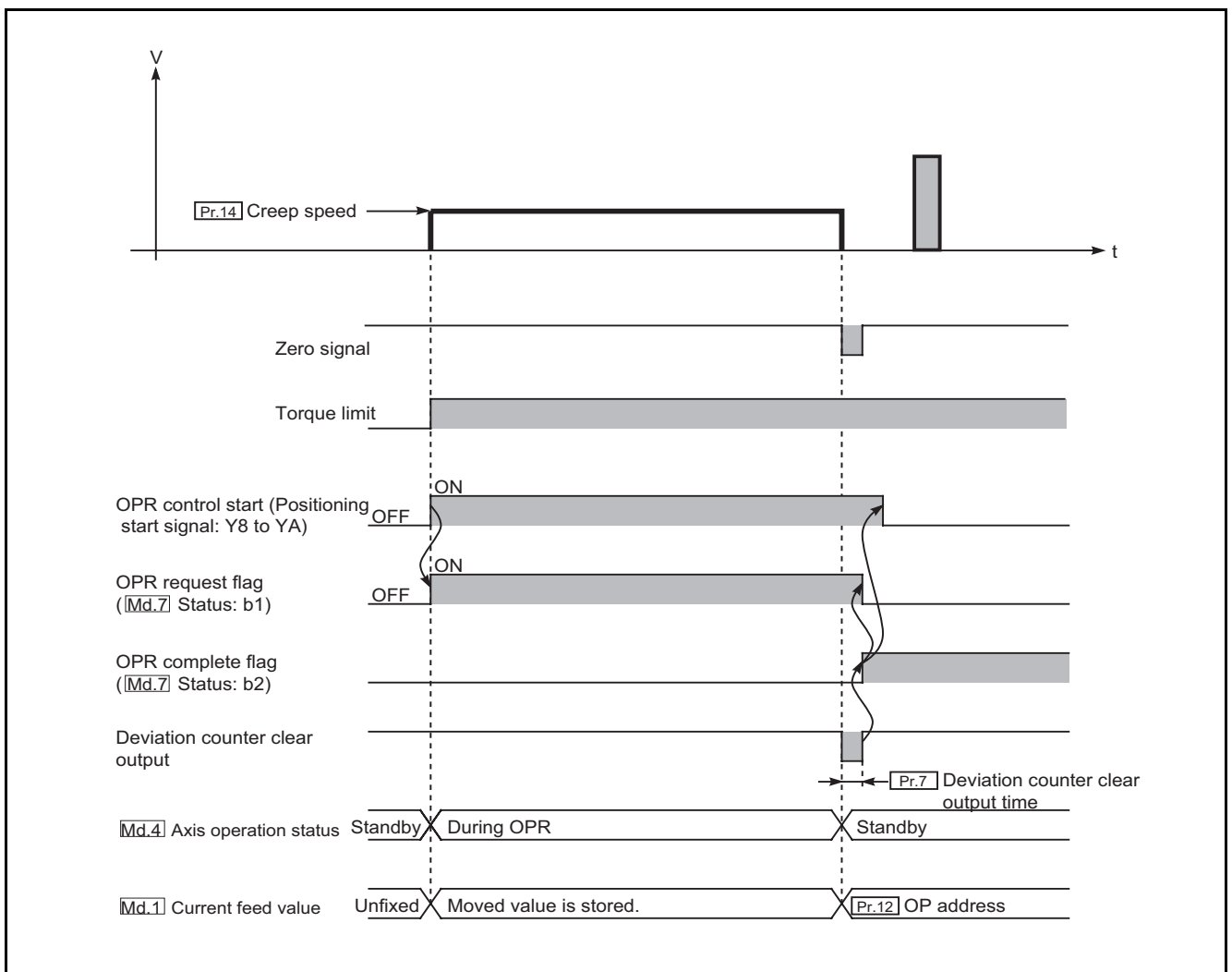

Figure 8.8 When the zero signal is input before the workpiece is stopped by the stopper

- (b) If the axis is started during zero signal ON, "Zero signal ON" error (error code: 202) occurs.

8.3 Fast OPR Control

8.3.1 Outline of the fast OPR control operation

■ Fast OPR control operation

In fast OPR control, positioning control is performed to "Md.1 Current feed value" stored in the QD72P3C3 by machine OPR control.

By setting "9001" in "Cd.5 Start method" and turning ON the positioning start signal (Y8 to YA), fast OPR control performs position control at high speed without positioning data, near-point dog, and zero signal.

The following describes the operation when starting fast OPR control.

1)	Set "9001" in " <u>Cd.5</u> Start method" and turn ON the positioning start signal (Y8 to YA).
2)	Position control is started to the OP address according to the OPR parameter (<u>Pr.10</u> to <u>Pr.15</u>) when machine OPR control was performed.
3)	The fast OPR control is completed.

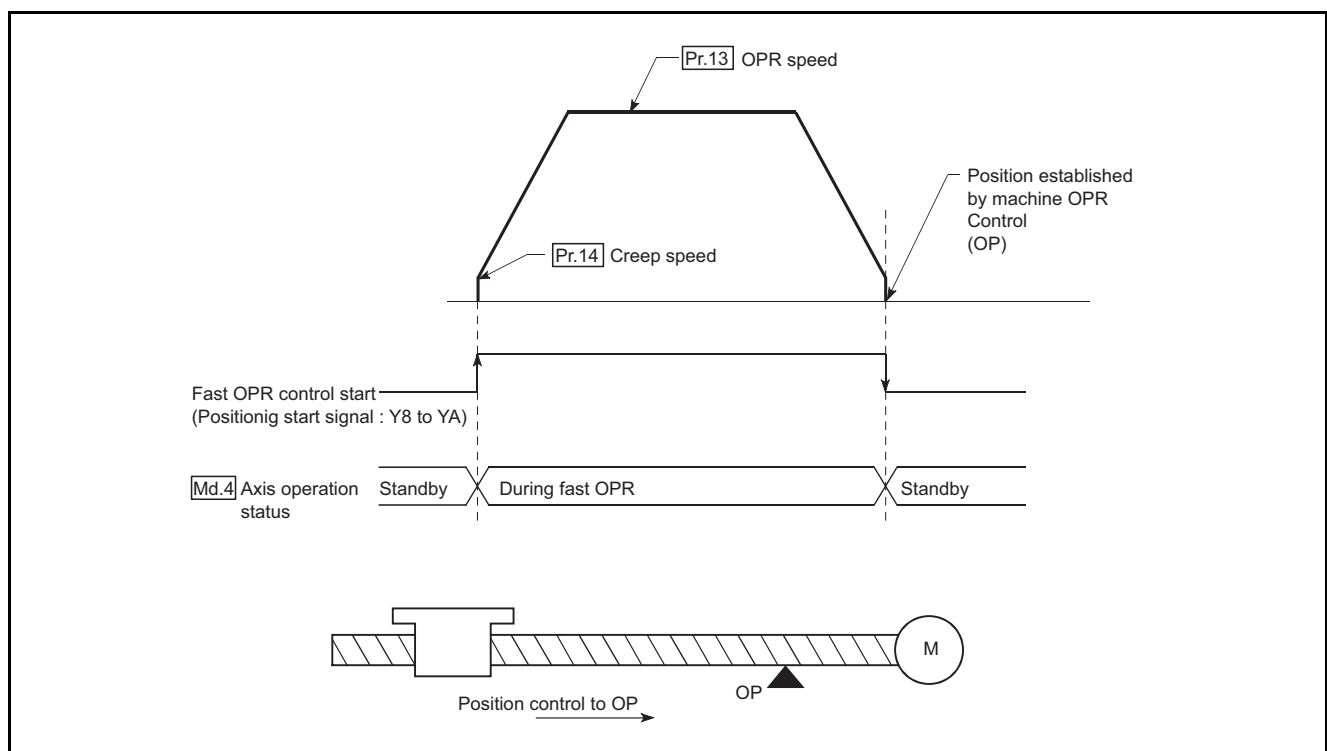

Figure 8.9 Fast OPR control

■ Precautions during operation

- (a) Perform fast OPR control after performing machine OPR control and the machine OP is established.
If fast OPR control is started without performing machine OPR control, "Machine OPR not performed" error (error code: 203) occurs.
- (b) In fast OPR control, "OPR complete flag" (Md.7 Status: b2) and "OPR request flag" (Md.7 Status: b1) do not change.
- (c) On completion of fast OPR control, " Pr.12 OP address" is not stored into " Md.1 Current feed value".
- (d) If movement amount to the OP exceeds 268435455pulses, position control to the OP is performed in every 268435455pulses with alternating between stop and start.

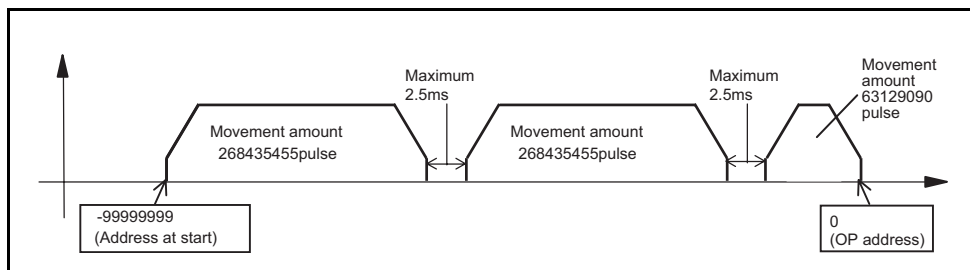

Figure 8.10 Fast OPR control when the movement amount is over 268435455pulses

8.4 Count Value Selection Function at OPR

This function stores "[Pr.12] OP address" to "[Md.3] Count value" when OPR is completed.
To use this function, set "[Pr.19] Count value selection at OPR" to "1: OP address set to count value".

CHAPTER9 POSITIONING CONTROL

This chapter describes details of the QD72P3C3 positioning control (control functions using positioning data).

9.1 Outline of Positioning Control

"Positioning control" is a control using "positioning data" stored in the QD72P3C3. Position control, speed control, and current value change are performed by setting the necessary items to the "positioning data".

Set the control method of "positioning control" to "[Da.2] Control method" in setting item of the positioning data.

The following table shows controls which can be defined as "positioning control" by the setting in "[Da.2] Control method".

Positioning control	[Da.2] Control method	Description
Position control (1-axis linear control)	1-axis linear control (ABS) 1-axis linear control (INC)	Performs positioning control from the starting address (current stop position) to the specified position using the specified one axis.
Speed control	Speed control (Forward run) Speed control (Reverse run)	Continuously outputs pulses corresponding to the "[Da.4] Command speed" set in positioning data.
Current value change	Current value change	Changes "[Md.1] Current feed value" to the address set in positioning data.

9.1.1 Data required for positioning control

The following table shows an outline of the "positioning data" configuration and setting contents required to perform "positioning control".

Setting item	Setting contents
[Da.1] Operation pattern	Select the type of operation pattern for positioning control to be performed. (Refer to Section 9.1.2.)
[Da.2] Control method	Set the control method defined for "positioning control". (Refer to Section 9.1)
[Da.3] ACC/DEC time	Set the acceleration/deceleration time for positioning control.
[Da.4] Command speed	Set speed at control execution.
[Da.5] Positioning address/movement amount	Set the value of set point, movement amount or current value change when performing position control. (Refer to Section 9.1.3.)

* Setting contents from [Da.1] to [Da.5] differ in setting requirement and description, depending on "[Da.2] Control method". (Refer to "Section 9.2 Positioning Data Setting".)

9.1.2 Positioning control operation patterns

Depending on movement amount, positioning control has two operation patterns: "positioning start (independent)" and "positioning start (continuous)".

Select the operation pattern at "[Da.1] Operation pattern".

["[Da.1] Operation pattern" setting contents]

" [Da.1] Operation pattern" setting	Setting contents
0: Positioning start (independent)	Select this item when performing positioning control whose movement amount is within 268435455pulses, regardless whether the system is the absolute system or incremental system.
5000: Positioning start (continuous)	Select this item when performing positioning control whose movement amount is over 268435455pulses, regardless whether the system is the absolute system or incremental system.

Example 1: Performing positioning control whose movement amount is within 268435455pulses

When performing position control from -99999999 (address at start) to 150000000 (address at end) in absolute system, since the movement amount is 250000000pulses, select "0: Positioning start (independent)" as "[Da.1] Operation pattern".

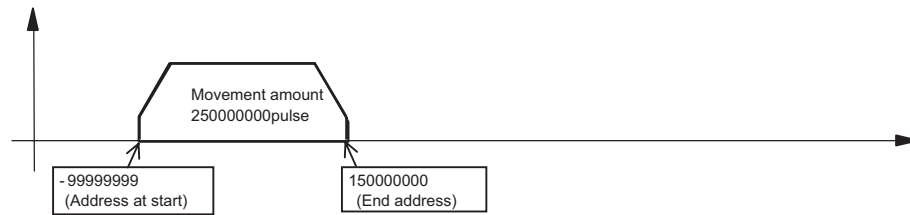

Example 2: Performing positioning control whose movement amount is over 268435455pulses

When performing position control from -99999999 (starting address) to 500000000 (end address) in absolute system, since the movement amount is 600000000pulses, select "5000: Positioning start (continuous)" as "[Da.1] Operation pattern".

* : The QD72P3C3 can output up to 268435455pulses at a time. When performing positioning control exceeding the number of pulses that can be output, perform movement in multiple times as the figure below.

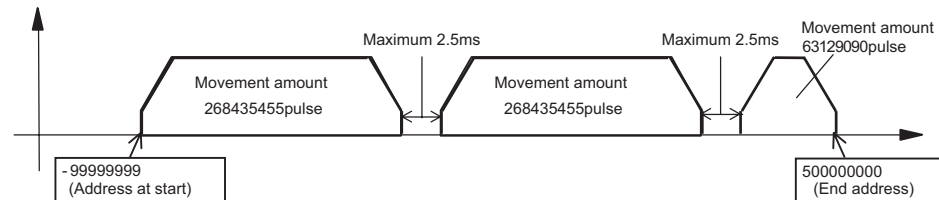

☒ POINT

- Positioning data of the QD72P3C3 is started by setting "0" to "Cd.5 Start method".
 - The BUSY signal (X8 to XA) turns ON even when position control of movement amount 0 is performed. However, since the ON time is short, the ON status may not be detected in the sequence program.
-

9.1.3 Specifying the positioning address

The following two methods are available for commanding a position in control using positioning data.

■ Absolute system

A position based on the OP (absolute address) is specified and positioning control is performed. This address is regarded as the positioning address. (The start point can be anywhere.)

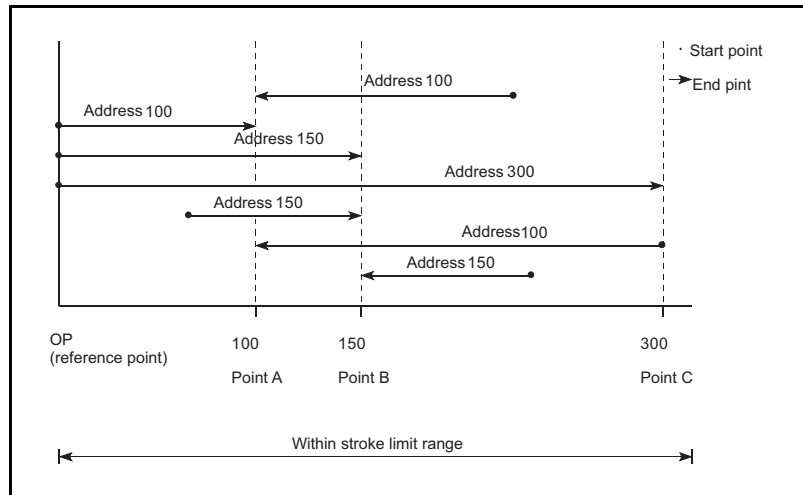

Figure 9.1 Absolute system positioning control

■ Incremental system

The position where the workpiece is currently stopped is regarded as the start point, and positioning control is performed by specifying movement direction and movement amount.

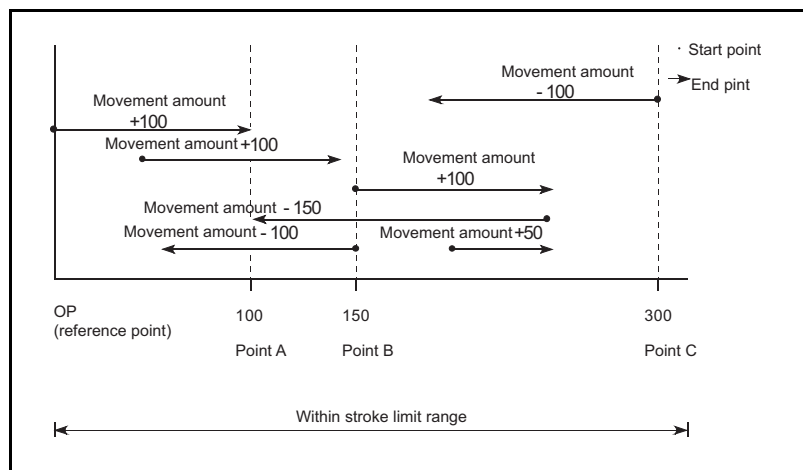

Figure 9.2 Incremental system positioning control

9.1.4 Checking the current value

■ Values representing the current value

In the QD72P3C3, the following address is used as a value representing the position. This address (current feed value) is stored in the monitor data area and is used in monitoring such as current value display.

Current feed value	<ul style="list-style-type: none"> • Value stored in "[Md.1] Current feed value" • The value is based on an address established with "machine OPR control". However, the address can be changed by current value change. • Update timing: 2.5ms
--------------------	--

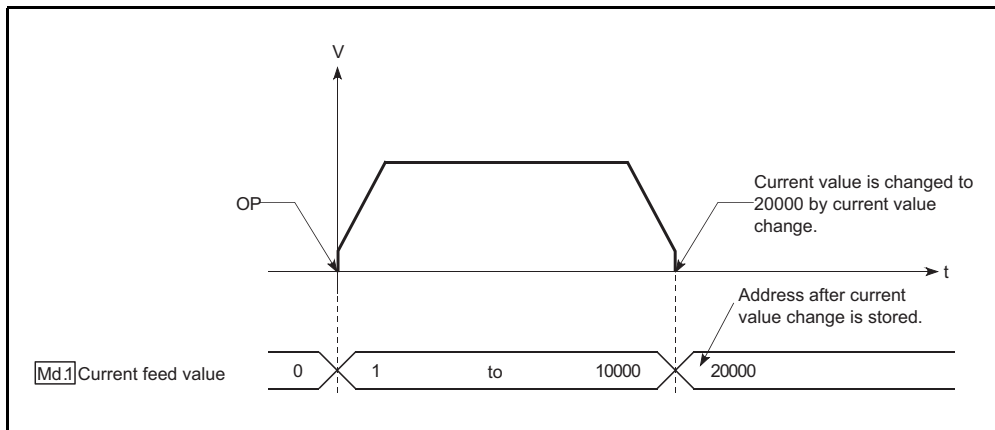

Figure 9.3 Current feed value

■ Current value when using the ring counter

When the counter format is set to "ring counter" in intelligent function module switch setting, the current value is repeatedly updated between 0 and "[Pr.17] Positioning range upper limit value" during speed control (when "[Pr.3] Current feed value during speed control" is set to "1: Update") or JOG operation.

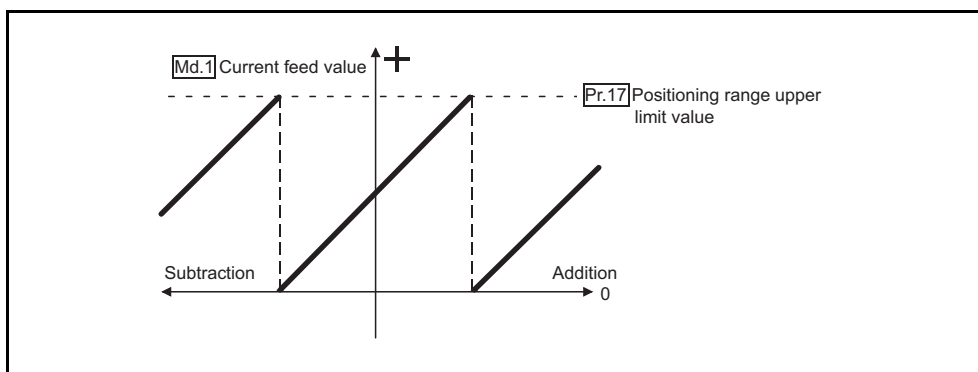

Figure 9.4 Current feed value when using the ring counter

■ Restrictions

If the stored "current feed value" is used for control, tolerance occurs by 2.5ms at update timing of the current value.

■ Monitoring the current value

The "current feed value" is stored in the following buffer memory and can be read using the "DFRO(P) instruction" from the programmable controller CPU.

	Buffer memory address		
	Axis 1	Axis 2	Axis 3
Md.1 Current feed value	70	170	270
	71	171	271

Example

* Program in which the current feed value of axis 1 is read to D70 and D71



9.2 Positioning Data Setting

9.2.1 Relation between each control and positioning data

The setting requirements and description for the setting items of the positioning data to be set differ depending on "[Da.2] Control method".

The following table shows the positioning data setting items of each control. For operation details and settings of each control, refer to Section 9.2.2 or the subsequent sections.

Positioning data \ Positioning control	Position control	Speed control	Current value change
[Da.1] Operation pattern	◎	◎	◎
[Da.2] Control method	◎	◎	◎
[Da.3] ACC/DEC time	◎	◎	-
[Da.4] Command speed	◎	◎	-
[Da.5] Positioning address/movement amount	◎	◎	◎

◎: Setting is required.

- : Setting not required. (Setting value is invalid. If setting, use the default value or a value within the range where no error occurs.)

9.2.2 1-axis linear control

In 1-axis linear control ("Da.2 Control method" = 1-axis linear control (ABS), 1-axis linear control (INC)), one motor is used to perform position control in set axis direction.

[1] 1-axis linear control (ABS)

■ Operation chart

In 1-axis linear control of absolute system, addresses established by a machine OPR control are used. Position control is performed from the current stop position (starting address) to the address set in "Da.5 Positioning address/movement amount" (end address).

Example

When the starting address (current stop position) is 1000 and the end address (positioning address) is 8000, position control is performed in the positive direction by a movement amount of 7000 (1000 to 8000).

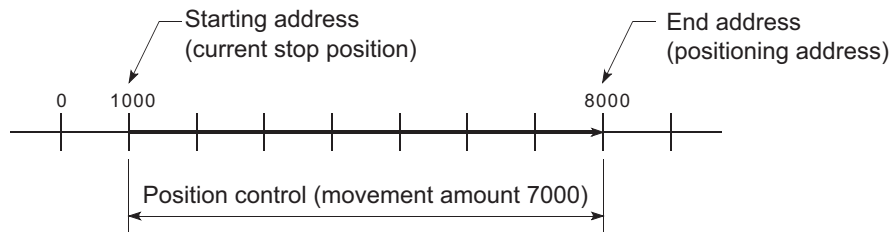

■ Positioning data setting example

The following table shows a setting example when "1-axis linear control (ABS)" is set in positioning data of axis 1.

	Setting item	Setting example	Setting contents
Axis 1 positioning data	Da.1 Operation pattern	Positioning start (independent)	Set positioning start (independent) assuming position control whose movement amount is within 268435455pulses is performed.
	Da.2 Control method	1-axis linear control (ABS)	Set 1-axis linear control in absolute system .
	Da.3 ACC/DEC time	1000ms	Set the acceleration/deceleration time for position control.
	Da.4 Command speed	50000pulse/s	Set the speed during movement to the positioning address.
	Da.5 Positioning address/ movement amount	8000pulse	Set the positioning address.

* For details of setting, refer to "Section 4.4 Positioning Data List".

[2] 1-axis linear control (INC)

■ Operation chart

In 1-axis linear control of incremental system, addresses established by a machine OPR control are used. Position control is performed from the current stop position (starting address) for the movement amount set in "[Da.5] Positioning address/movement amount". The movement direction is determined by the sign of the movement amount.

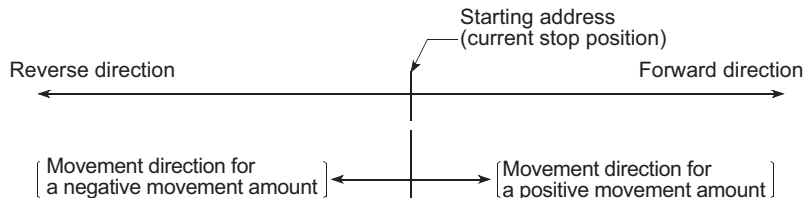

Example

When the starting address is 5000 and the movement amount is -7000, position control is performed to the -2000 position.

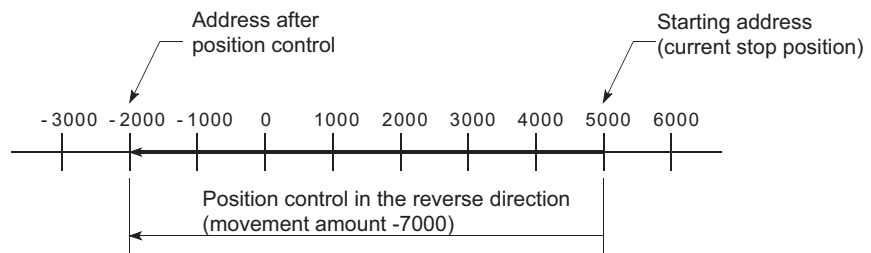

■ Positioning data setting example

The following table shows a setting example when "1-axis linear control (INC)" is set in positioning data of axis 1.

	Setting item	Setting example	Setting contents
Axis 1 positioning data	[Da.1] Operation pattern	Positioning start (independent)	Set positioning start (independent) assuming position control whose movement amount is within 268435455pulses is performed.
	[Da.2] Control method	1-axis linear control (INC)	Set 1-axis linear control in incremental system.
	[Da.3] ACC/DEC time	1000ms	Set the acceleration/deceleration time for position control.
	[Da.4] Command speed	50000pulse/s	Set the speed during movement.
	[Da.5] Positioning address/movement amount	-7000pulse	Set the movement amount.

* For details of setting, refer to "Section 4.4 Positioning Data List".

9.2.3 Speed control

In "speed control" ("Da.2 Control method" = Speed (forward run), Speed (reverse run)), pulses are continued outputting at the speed set in "Da.4 Command speed" until the axis stop signal (Y4 to Y6) is input in axis direction set for positioning data.

The speed control has two types: control that starts in forward direction "speed control (forward run)" and control that starts in reverse direction "speed control (reverse run)".

■ Operation chart

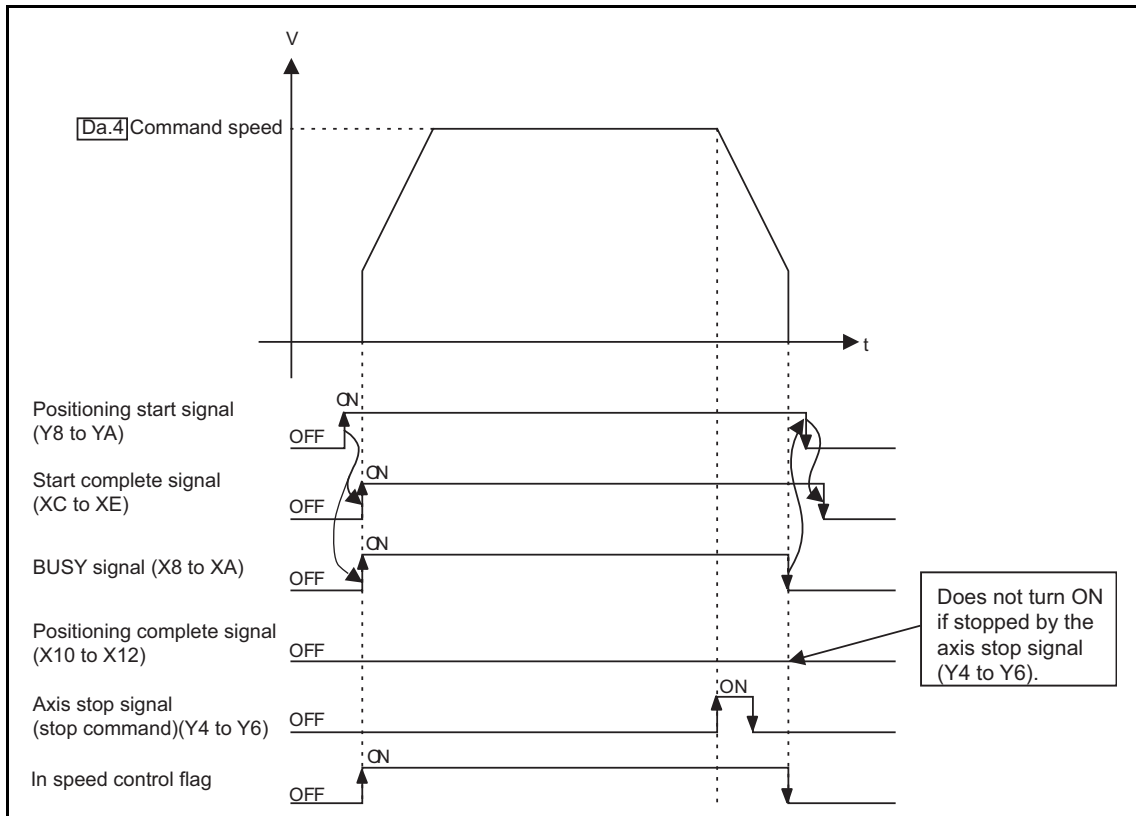

Figure 9.5 Speed control operation timing

■ Current feed value during speed control

"Md.1 Current feed value" during speed control differs depending on "Pr.3 Current feed value during speed control" setting as follows.

"Pr.3 Current feed value during speed control" setting	Md.1 Current feed value
0: No update	The current feed value at the start of speed control is held.
1: Update	The current feed value is updated.

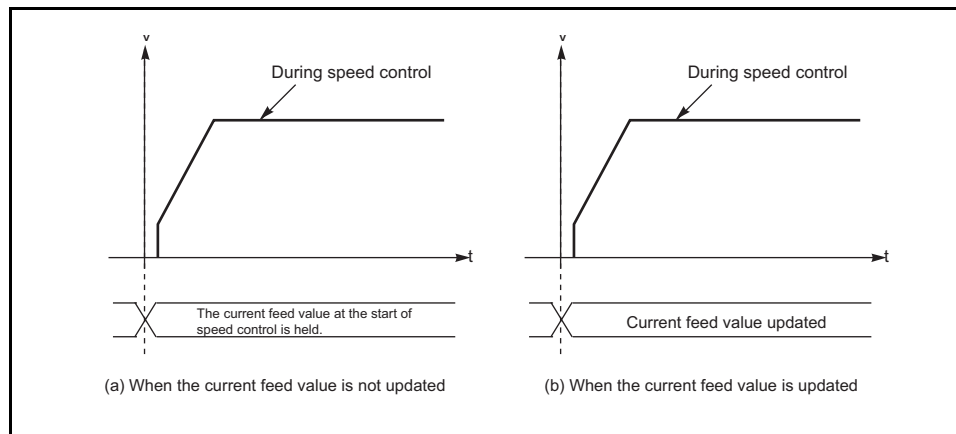

Figure 9.6 Current feed value during speed control

■ Current feed value when using the ring counter

When the counter format is set to "ring counter" in intelligent function module switch setting, the current feed value is repeatedly updated between 0 and "Pr.17 Positioning range upper limit value -1".

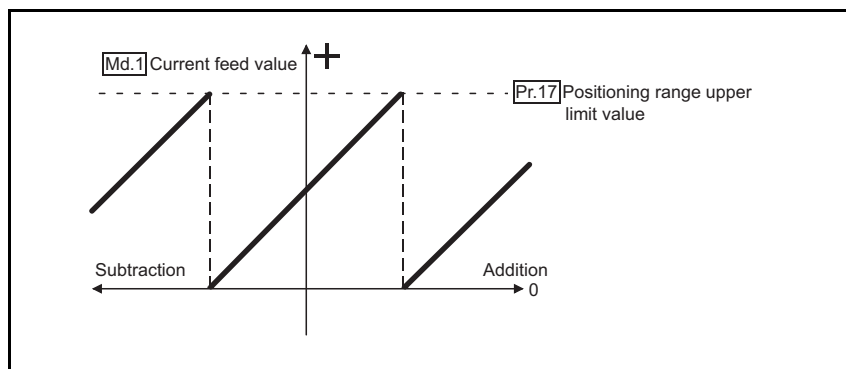

Figure 9.7 Current feed value when using the ring counter

■ Restrictions

Software stroke limit range during speed control is checked when "Pr.4 Current feed value during speed control" is set to "1: Update" and the counter format is set to "linear counter" in intelligent function module switch setting.

■ Positioning data setting example

The following table shows a setting example when "speed control in forward run" is set in positioning data of axis 1.

	Setting item	Setting example	Setting contents
Axis 1 positioning data	Da.1 Operation pattern	Positioning start (independent) or positioning start (continuous)	Set "0: Positioning start (independent)" or "5000: Positioning start (continuous)".
	Da.2 Control method	Speed control (forward run)	Set the speed control in forward run.
	Da.3 ACC/DEC time	1000ms	Set the acceleration/deceleration time for speed control.
	Da.4 Command speed	50000pulse/s	Set the speed to be commanded.
	Da.5 Positioning address/ movement amount	-	Setting not required (Setting value is ignored).

* For details of setting, refer to "Section 4.4 Positioning Data List".

9.2.4 Current value change

Current value change performs a control to change "[Md.1] Current feed value" to any address.

■ Operation chart

The following chart shows the operation timing of current value change. Turning ON the positioning start signal (Y8 to YA) changes "[Md.1] Current feed value" to the value set to "[Da.5] Positioning address/movement amount".

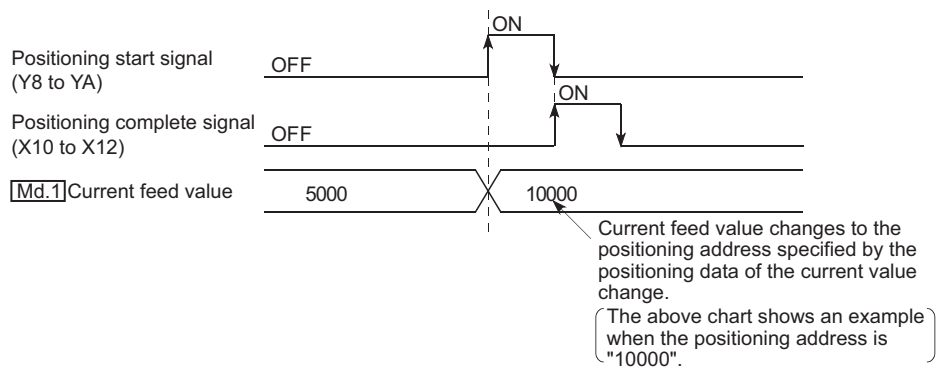

■ Restrictions

The current value cannot be changed in the following cases.

- When the linear counter is set for the counter format, if the value set to "[Da.5] Positioning address/movement amount" (value of current value change) is out of "Software stroke limit upper/lower limit value ([Pr.1], [Pr.2])" setting range, "Software stroke limit +, -" error (error code: 516, 517) occurs, and the current value cannot be changed.
- When the ring counter is set for the counter format, if the value set to "[Da.5] Positioning address/movement amount" (value of current value change) is out of 0 to "[Pr.17] Positioning range upper limit value -1" range, "Out of positioning address/movement amount setting range" error (error code: 509) occurs, and the current value cannot be changed.

■ Positioning data setting example

The following table shows a setting example when "current value change" is set in positioning data of axis 1.

	Setting item	Setting example	Setting contents
Axis 1 positioning data	Da.1 Operation pattern	Positioning start (independent)	Set positioning start (independent) assuming position control whose movement amount is within 268435455pulses is performed.
	Da.2 Control method	Current value change	Set the current value change.
	Da.3 ACC/DEC time	-	Setting not required (Setting value is ignored).
	Da.4 Command speed	-	Setting not required (Setting value is ignored).
	Da.5 Positioning address/ movement amount	10000pulse	Set the destination address.

* For details of setting, refer to "Section 4.4 Positioning Data List".

9.3 Multiple axes concurrent start control

The QD72P3C3 allows the axes to be started concurrently on a pulse level by turning ON the positioning start signal (Y8 to YA) within the same scan during positioning control.

■Precautions

- (a) The speed limit function is valid on an axis basis.
- (b) To perform stop processing, the stop command (axis stop signal (Y4 to Y6) ON) must be issued to each axis.
Note that the axes do not stop concurrently.
- (c) JOG operation cannot start the axes concurrently.
- (d) Note if an error occurs in any axis, it is processed in the corresponding axis.

CHAPTER10 JOG OPERATION

This chapter describes details of the QD72P3C3 JOG operation.

10.1 Outline of JOG Operation

☒IMPORTANT

When performing JOG operation near the out of moving range, provide a safety circuit externally.

- * If an external safety circuit is not provided, the workpiece may advance over the moving range, resulting in an accident.
-

"JOG operation" is a control method to move a workpiece by given movement amount without positioning data (the pulse is kept outputting while the JOG start signal (YC to Y11) is ON). This control is used to move the workpiece to within the software stroke limit range if operation has been stopped by the positioning control system connection check or by the software stroke limit function.

■ JOG operation

In JOG operation, while the forward run JOG start signal (YC, YE, and Y10) or the reverse run JOG start signal (YD, YF, and Y11) is ON, the QD72P3C3 outputs pulses to the drive unit, and moves the workpiece in the specified direction.

The following describes an example of JOG operation.

1)	Turning ON the JOG start signal (YC to Y11) starts acceleration in the direction specified in the JOG start signal (YC to Y11) and at the time set in "JOG.2 JOG ACC/DEC time". At this time, the BUSY signal (X8 to XA) turns from OFF to ON.
2)	When the workpiece during acceleration reaches the speed set in "JOG.1 JOG speed", it continues movement at this speed. (The workpiece moves at constant speed from 2) to 3).)
3)	Turning OFF the JOG start signal (YC to Y11) starts deceleration from the speed set in "JOG.1 JOG speed" to the one set in "JOG.2 JOG ACC/DEC time".
4)	The workpiece stops when it decelerates to the speed set in "Pr.5 Bias speed at start". At this time, the BUSY signal (X8 to XA) turns from ON to OFF.

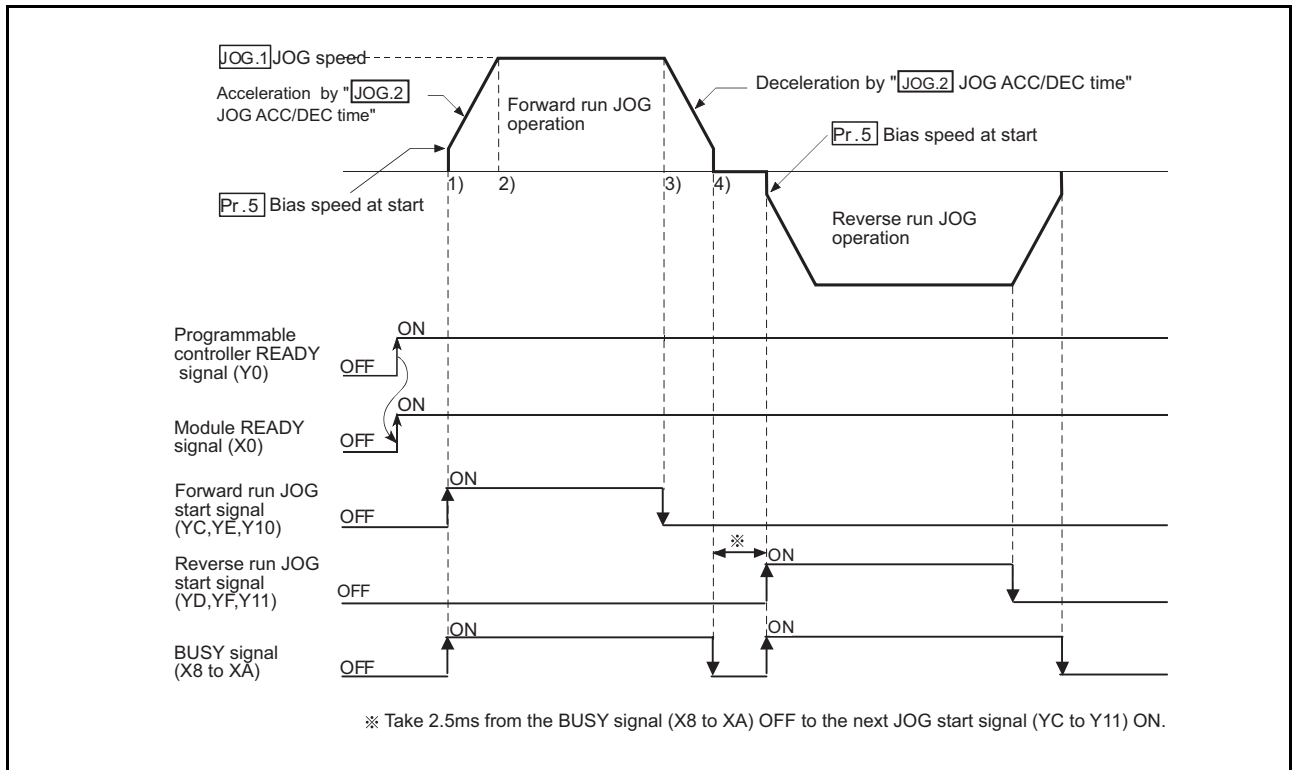

Figure 10.1 JOG operation start timing chart

■ JOG operation monitor

When using GX Developer to directly monitor the buffer memory, refer to "Section 4.5 Monitor Data List".

When using the monitor function of GX Configurator-PT to monitor, refer to "Section 6.6 Monitor/Test".

■ Precautions during operation

Before starting JOG operation, grasp the following points.

- (a) Set the JOG data before starting JOG.
(The settings cannot be changed during JOG operation.)
- (b) Setting a great value to "[JOG.1] JOG speed" from the beginning is dangerous.
For safety, set a small value at first and check the movement. After that, gradually increase the value and adjust the speed optimal for control.
- (c) "[JOG.1] JOG speed" is higher than the speed set in "[Pr.4] Speed limit value", the axis operates at "[Pr.4] Speed limit value" and "Out of speed range" warning (warning code: 20) occurs.
- (d) "[JOG.1] JOG speed" is lower than "[Pr.5] Bias speed at start", operation starts at "[Pr.5] Bias speed at start" and "Out of speed range" warning (warning code: 20) occurs.
- (e) Even if a warning occurs, JOG operation is continued.

■ Error during operation

If operation is stopped by the software stroke limit function, JOG operation can be performed within the software stroke limit range after an axis error reset. (For details, refer to "Section 11.4".)

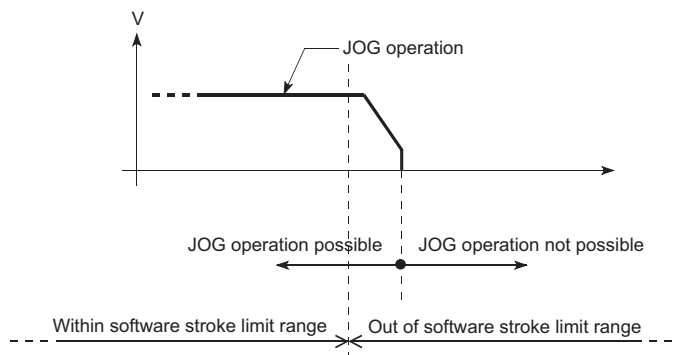

10.2 JOG Operation Execution Procedure

The following shows the procedures for JOG operation.

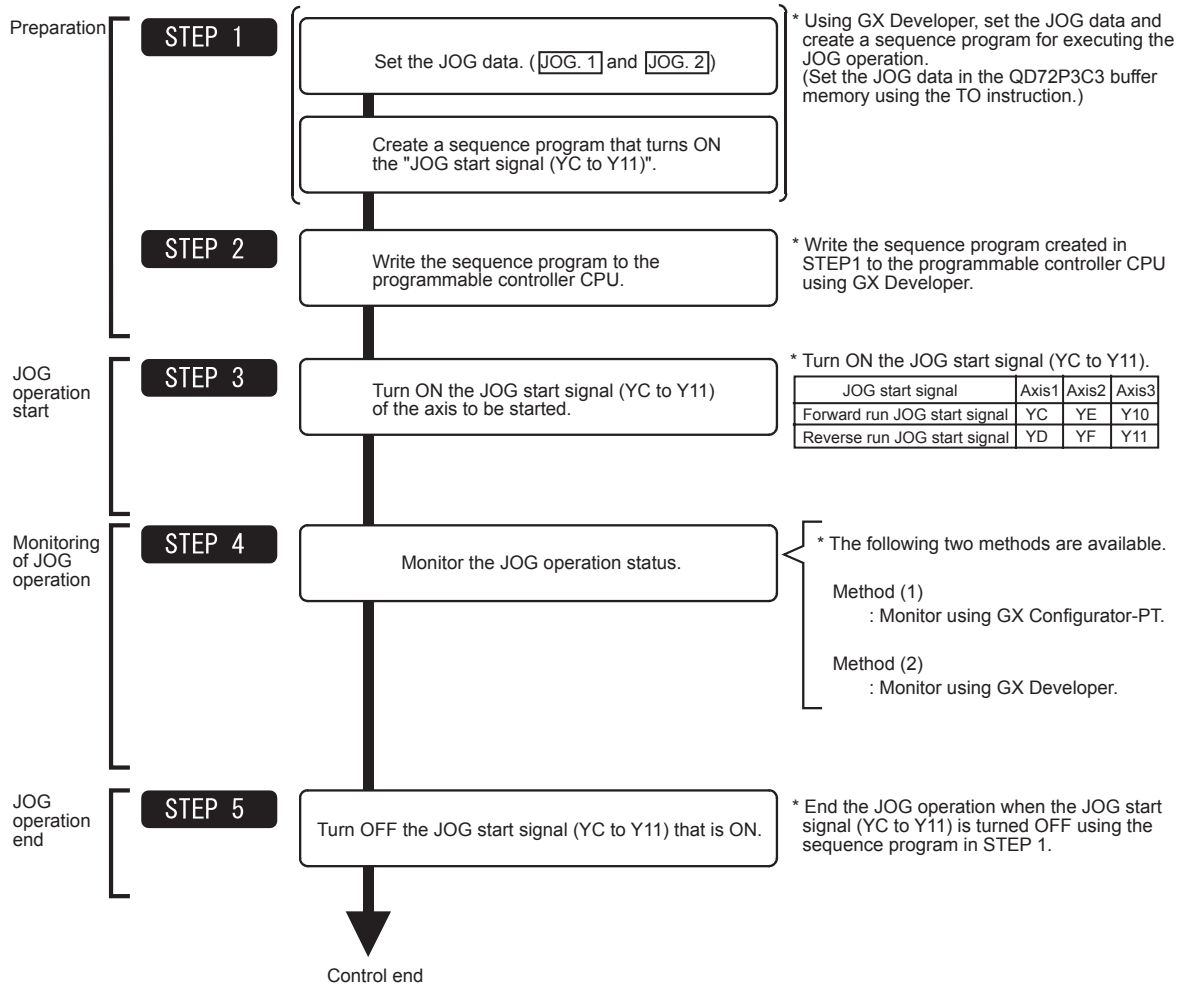

For details of JOG operation start program, refer to "Section 5.7 Simple Reciprocating Operation".

Remark

- It is assumed that machinery such as an external safety circuit has already been installed.
- Preset the external I/O signal logic, pulse output mode and pulse rotation direction with the intelligent function module switches. (For details, refer to "Section 5.6 Intelligent Function Module Switch Setting".)
- Set parameters such as speed limit value and bias speed at start as necessary.

10.3 JOG Operation Example

(1) When the "axis stop signal" (Y4 to Y6) is turned ON during JOG operation

When the "axis stop signal" (Y4 to Y6)" is turned ON during JOG operation, JOG operation results in a "deceleration stop".

If turning ON the JOG start signal (YC to Y11) while the axis stop signal (Y4 to Y6) is ON, "Stop signal ON at start" error (error code: 102) occurs and JOG does not start. It can be started by resetting the axis error, turning OFF the axis stop signal (Y4 to Y6), and turning the JOG start signal (YC to Y11) from OFF to ON again.

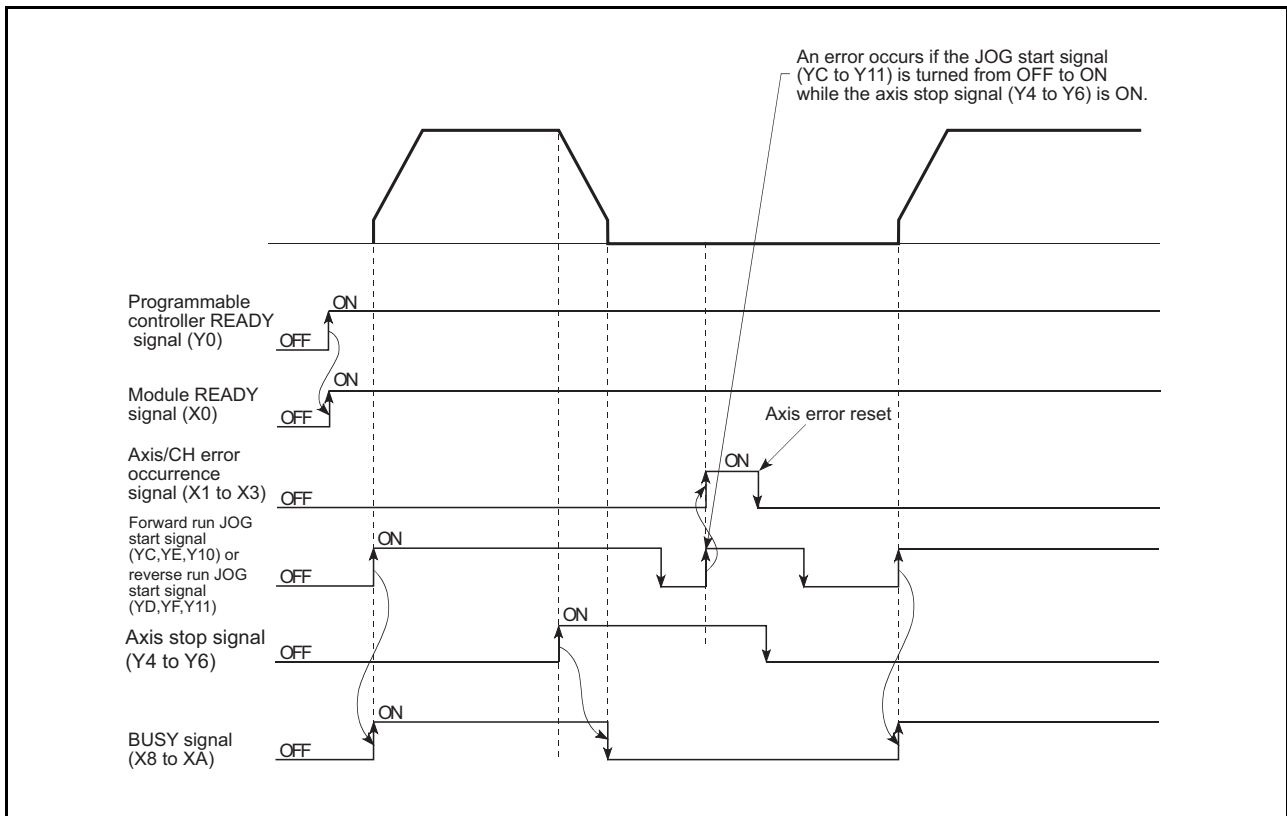

Figure 10.2 Operation when the axis stop signal (Y4 to Y6) is turned ON during JOG operation

(2) When the forward run JOG command signal and the reverse run JOG command signal are simultaneously turned ON

When the "forward run JOG start signal (YC, YE, Y10)" and "reverse run JOG start signal (YD, YF, Y11)" are simultaneously turned ON in one axis, the priority is given to the former. In this case, the "reverse run JOG start signal (YD, YF, Y11)" becomes effective when the BUSY signal (X8 to XA) of the QD72P3C3 turns OFF.

However, if the forward run JOG operation is stopped by the axis stop signal (Y4 to Y6) or axis error, the reverse run JOG operation is not performed even though the "reverse run JOG start signal (YD, YF, Y11)" is ON.

Note if the forward run JOG command signal is turned ON during reverse run JOG operation, the reverse run JOG operation is taken precedence.

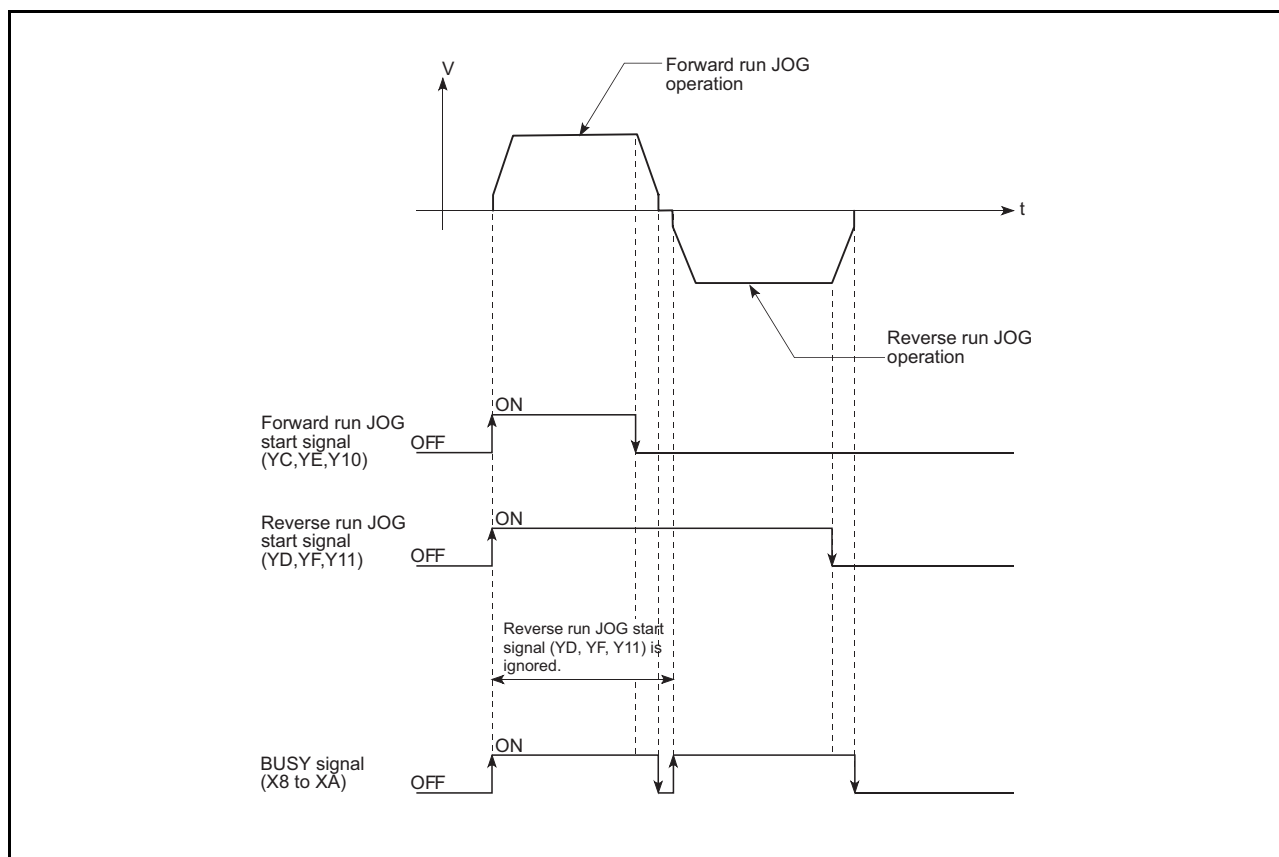

Figure 10.3 Operation when the reverse run JOG start signal (YD, YF, Y11) is turned ON during forward run JOG operation

(3) When the "JOG start signal (YC to Y11)" is turned ON again during deceleration caused by turning the "JOG start signal (YC to Y11)" from ON to OFF

When the "JOG start signal (YC to Y11)" is turned ON again during deceleration caused by turning the "JOG start signal (YC to Y11)" from ON to OFF, the JOG start signal (YC to Y11) is ignored.

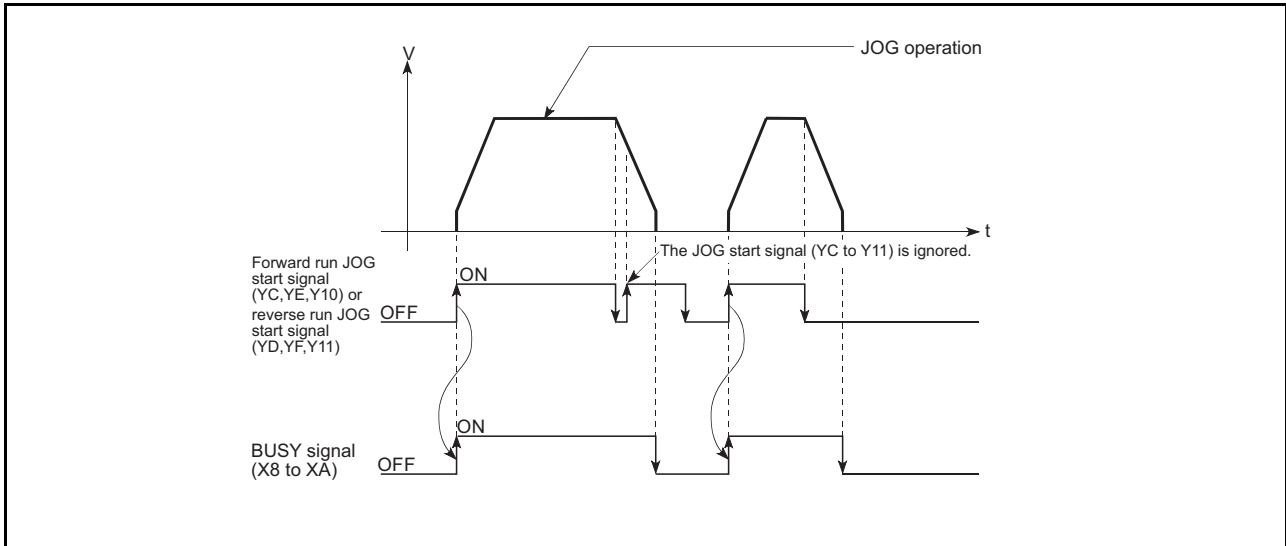

Figure 10.4 Operation when the JOG start signal (YC to Y11) is turned ON during deceleration

(4) When the "axis stop signal (Y4 to Y6)" is turned OFF after a stop caused by turning ON the "axis stop signal (Y4 to Y6)" with the "JOG start signal (YC to Y11)" ON

When the "axis stop signal (Y4 to Y6)" is turned OFF after a stop caused by turning ON the "axis stop signal (Y4 to Y6)" with the "JOG start signal (YC to Y11)" ON, JOG operation is not performed.

JOG operation can be started by turning the "JOG start signal (YC to Y11)" from OFF to ON again.

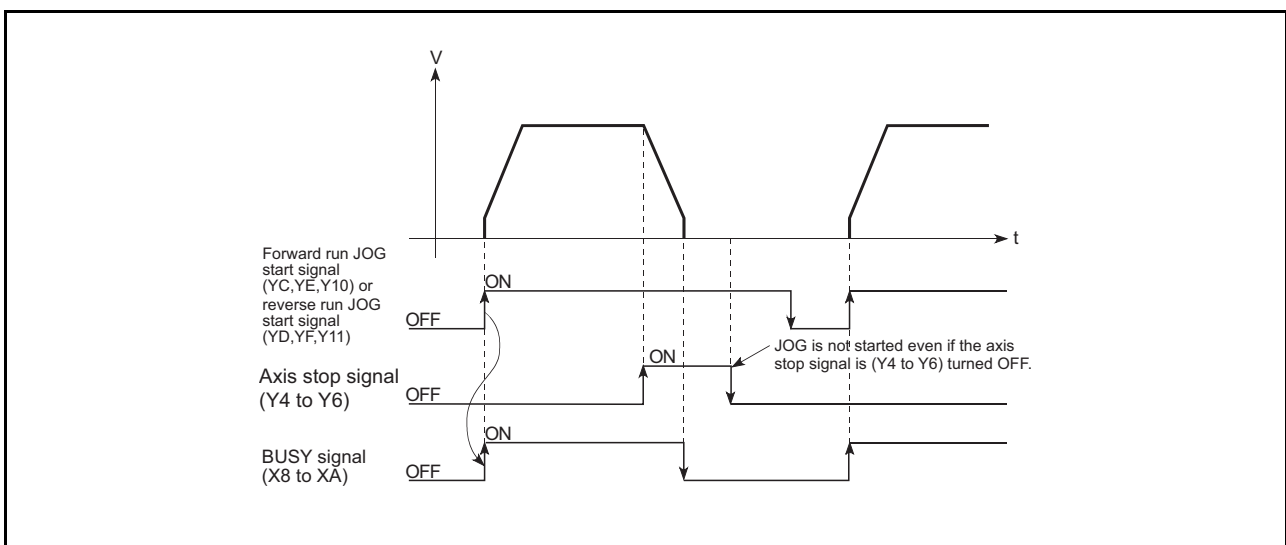

Figure 10.5 Operation when the axis stop signal (Y4 to Y6) is turned from ON to OFF with the JOG start signal (YC to Y11) ON

CHAPTER 11 AUXILIARY FUNCTION

11.1 Outline of the Auxiliary Function

This function limits a control and add functions when performing OPR control, positioning control, and JOG operation. These auxiliary functions are performed by parameter setting, sequence programs, etc.

The "auxiliary function" has the following functions.

Table 11.1 Auxiliary function list

Auxiliary function	Description	Reference
Speed limit function	If the command speed exceeds the "[Pr.4] Speed limit value" during control, this function limits the command speed to within the "[Pr.4] Speed limit value" setting range.	Section 11.2
Speed change function	This function changes the speed during the constant speed of speed control or JOG operation. Set the new speed in "[Cd.1] New speed value" and change the speed according to "[Cd.3] Speed change request".	Section 11.3
Software stroke limit function	When a command is issued to the outside of the upper limit/lower limit stroke limit setting range, which are set in the parameters, this function does not perform a control for that command.	Section 11.4
Hardware stroke limit function	This function executes the deceleration stop by the limit switch connected to the external device connector of the QD72P3C3.	Section 11.5
ACC/DEC process function	This function adjusts the acceleration/deceleration processing of control.	Section 11.6

11.2 Speed Limit Function

If the command speed exceeds the "Speed limit value" during control, this function limits the command speed to within the "Speed limit value" setting range.

(1) Relation between the speed limit function and each control

The following table shows the relation between the "speed limit function" and each control.

Table 11.2 Relation between the speed limit function and each control

Control type		Speed limit function	Speed limit value	Operation when speed limit value is exceeded
OPR control	Machine OPR control	◎	[Pr.4] Speed limit value	Does not operate.
	Fast OPR control	◎		"Out of OPR speed setting range (error code: 913)" error or "Out of creep speed setting range (error code: 914)" error occurs. (Refer to Section 4.2 Parameter List.)
Positioning control	Position control (1-axis linear control)	◎		"Out of speed range" warning (warning code: 20) occurs, and the axis is controlled by the speed limit value.
	Speed control	◎		
	Current value change	-		Setting value is invalid.
JOG operation		◎	[Pr.4] Speed limit value	"Out of speed range" warning (warning code: 20) occurs, and the axis is controlled by the speed limit value.

◎: Setting is required.

- : Setting not required (Setting value is invalid. If setting, use the default value or a value within the range where no error occurs.)

(2) Setting the speed limit function

To use the "speed limit function", set the "speed limit value" in the parameter as shown in the following table, and write it to the QD72P3C3. (The "speed limit value" depends on the motor used. Set it according to the motor used.)

The setting contents are enabled when the programmable controller CPU READY signal (Y0) is turned from OFF to ON.

Table 11.3 Relevant parameter

Setting item	Setting value	Setting contents	Factory default value
[Pr.4] Speed limit value	→	Set the speed limit value (maximum speed during control).	8000 (pulse/s)

* For details of the setting contents, refer to "Section 4.2 Parameter List".

11.3 Speed Change Function

This function changes the speed within "Pr.4 Speed limit value" during the constant speed of speed control or JOG operation.

Set the new speed in "Cd.1 New speed value". The speed is changed according to "Cd.3 Speed change request".

The acceleration/deceleration time at speed change and deceleration stop time to stop control after speed change are the values set in "Cd.2 ACC/DEC time at speed change".

(1) Control contents

The following shows the operation during speed change.

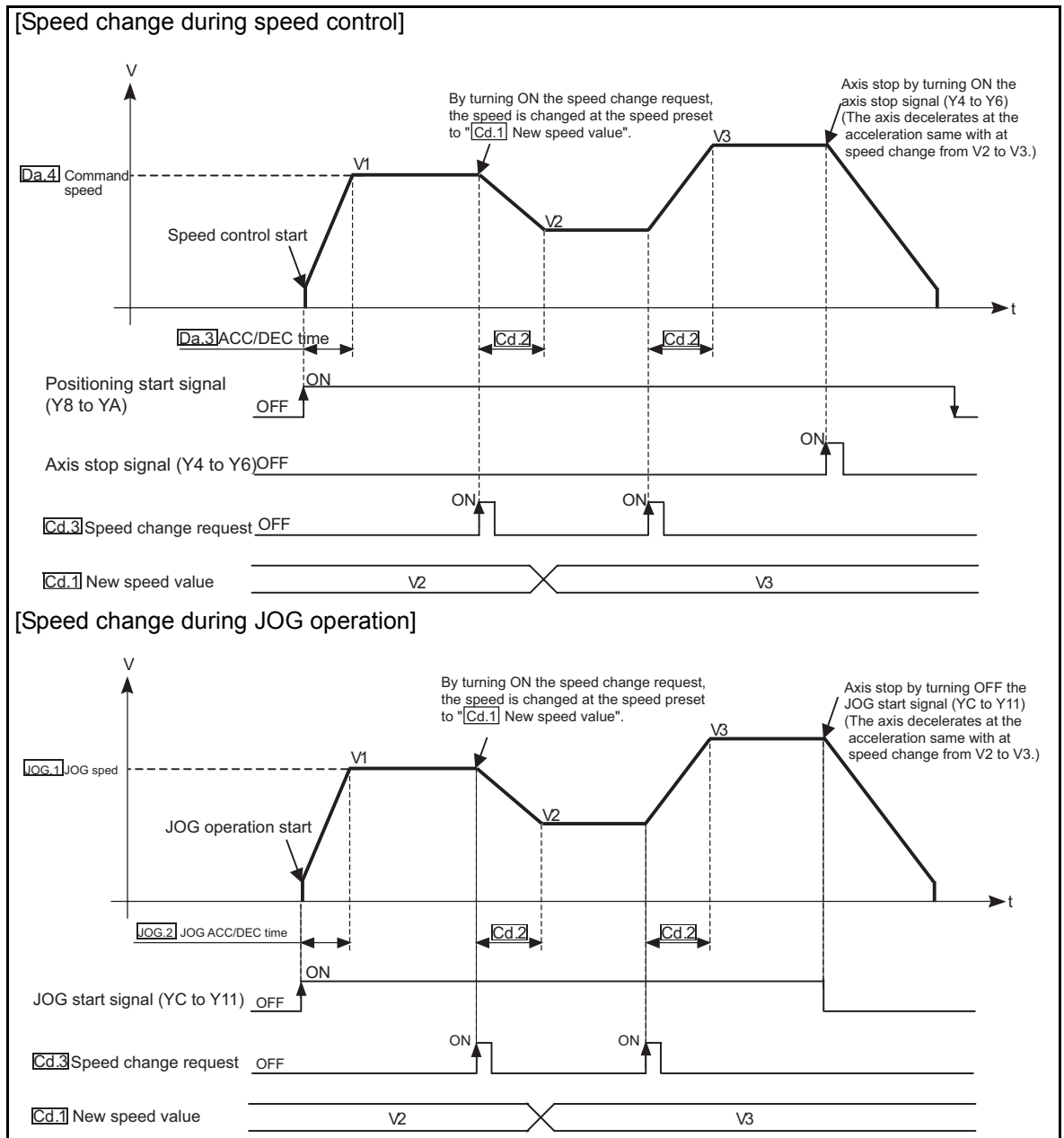

Figure 11.1 Speed change operation

(2) Precautions during control

- (a) When turning ON the axis stop signal (Y4 to Y6) or OFF the JOG start signal (YC to Y11) during acceleration/deceleration using the speed change function, the axis continues decelerating at the accelerated velocity at the acceleration/deceleration until it reaches to "Pr.5 Bias speed at start", and then stops.

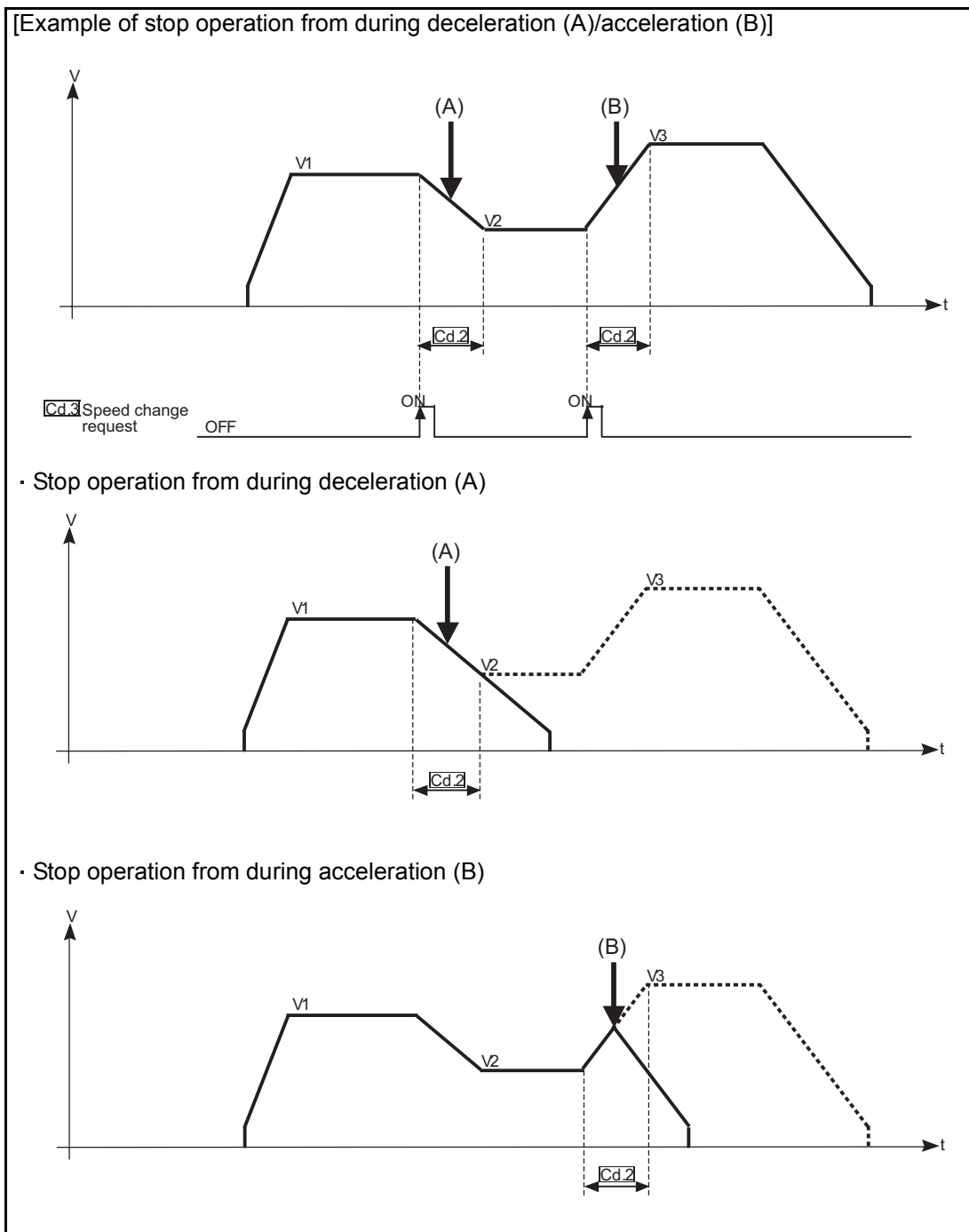

Figure 11.2 Operation when turning ON the axis stop signal (Y4 to Y6) or OFF the JOG start signal (YC to Y11) before the axis reaches to the speed change value

- (b) The speed cannot be changed in the following cases. (The speed change request is ignored.)
- During deceleration started by turning ON the axis stop signal (Y4 to Y6)
 - During deceleration started by turning OFF the JOG start signal (YC to Y11)
- (c) If speed change request is made during position control, OPR control or acceleration/deceleration, "Speed change disabled" warning (warning code: 22) occurs and the speed cannot be changed.
- (d) If the value set in " New speed value" is equal to or more than " Speed limit value", "Out of speed range" warning (warning code: 20) occurs and the speed is controlled at " Speed limit value".
- Also, if the value set in " New speed value" is less than " Bias speed at start", "Out of speed range" warning (warning code: 20) occurs and the speed is controlled at " Bias speed at start".

11.4 Software Stroke Limit Function

This function sets the upper/lower limits of workpiece movable range using the address (**MD.1** Current feed value) established by the machine OPR control and disables the movable command if it is issued to out of the setting range.

- This function works for "**MD.1** Current feed value" and "**DA.5** Positioning address/movement amount" (value of current value change).
- This function works at operation start and during operation.

Set the upper/lower limits of the workpiece movable range in "**Pr.1** Software stroke limit upper limit value"/"**Pr.2** Software stroke limit lower limit value".

(1) Movable region

The following figure shows the workpiece movable range when the software stroke limit function is used.

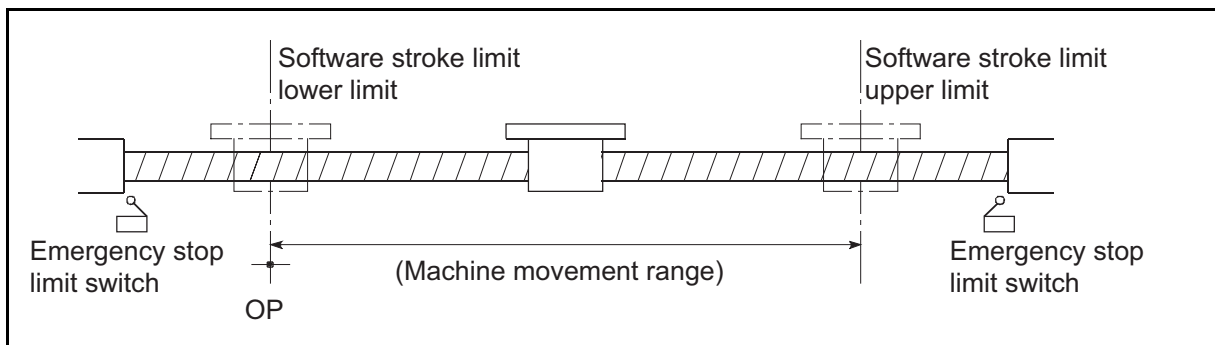

Figure 11.3 Workpiece movable range

(2) Software stroke limit check details

Check details		Processing at error
1)	"Md.1 Current feed value" out of the software stroke limit range is defined as an "error".	An "error" occurs.
2)	"Da.5 Positioning address/movement amount" (value of current value change) out of the software stroke limit range is defined as an "error".	(Error code: 516, 517)

(3) Relation between the software stroke limit function and each control

The following table shows the relation between the software stroke limit function and each control.

Control type		Software stroke limit check	Processing at check
OPR control	Machine OPR control	-	Unchecked
	Fast OPR control	-	
Positioning control	Position control (1-axis linear control)	◎	(2) 1) and (2) 2) above are checked at operation start. Therefore, positioning control out of the software stroke limit range is not performed.
	Speed control	○*	(2) 1) above is checked. •At operation start The axis does not start if the workpiece is out of the software stroke limit range. •During operation The axis starts deceleration to a stop when it exceeds the software stroke limit range.
	Current value change	◎	(2) 2) above is checked. If the value of current value change is out of the software stroke limit range, the current value is not changed.
JOG operation		◎*	(2) 1) above is checked. •At operation start The axis can be started only in the direction from the position out of the software stroke limit range to within the software stroke limit range (movable region). •During operation The axis starts deceleration to a stop when it exceeds the software stroke limit range.

◎: Checked

○: Is not checked if the current feed value is not updated (refer to "Current feed value during speed control") during speed control.

-: Unchecked

* When the counter format is set to "ring counter" in intelligent function module switch setting, software stroke limit check is not made.

(4) Precautions during software stroke limit check

- A machine OPR control must be performed beforehand for the "software stroke limit function" to work properly.
- Due to processing inside of the QD72P3C3, the software stroke limit check may delay by 2.5ms at maximum.

(5) Setting the software stroke limit function

To use the "software stroke limit function", set the required values in the parameters shown in the following table, and write them to the QD72P3C3.

The setting contents are enabled when the programmable controller CPU READY signal (Y0) is turned from OFF to ON.

Setting item	Setting value	Setting contents	Factory default value
<input type="text" value="Pr.1"/> Software stroke limit upper limit value	→	Set the upper limit value of the movable region.	1073741823
<input type="text" value="Pr.2"/> Software stroke limit lower limit value	→	Set the lower limit value of the movable region.	-1073741824

* For details of the setting contents, refer to "Section 4.2 Parameter List".

Set the values so that the formula (Software stroke limit upper limit value) > (Software stroke limit lower limit value) is satisfied.

If this formula is not satisfied, "Software stroke limit upper/lower limit value error" (error code: 901) occurs.

11.5 Hardware Stroke Limit Function

WARNING

When wiring hardware stroke limit is required, wire it in negative logic and use normally closed contact. Setting positive logic and using normally open contact may result in serious accident.

This function stops control (deceleration stop) by a signal input from the limit switch. To use this function, install limit switches to the upper limit/lower limits within physically movable range.

Stopping control before the axis reaches to the upper/lower limit in physically movable range prevents damage to equipment.

Normally, install the limit switches to "within the stroke limit for drive unit side/stroke end" to stop control before the axis reaches to the stroke limit for drive unit side/stroke end.

(1) Control contents

The following shows the operation of the hardware stroke limit function.

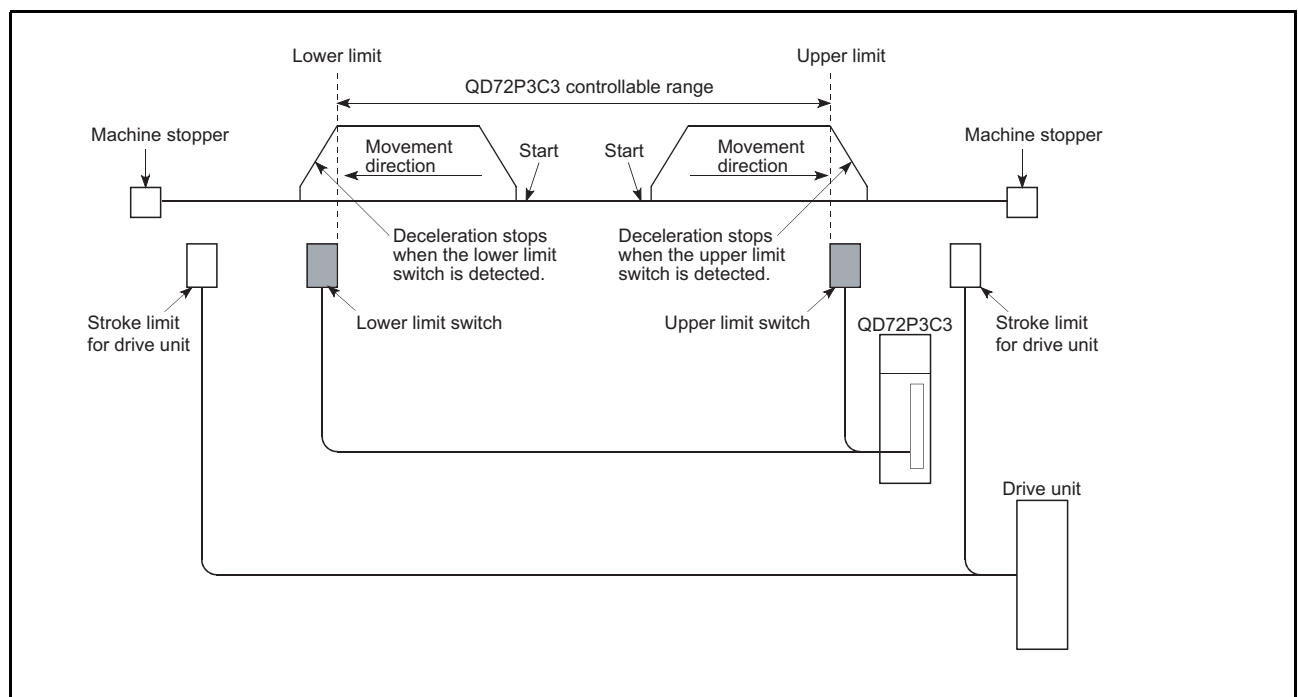

Figure 11.4 Operation chart of the hardware stroke limit function

(2) Hardware stroke limit wiring

To use the hardware stroke limit function, wire the terminals of the QD72P3C3 upper limit/lower limit signals as the figure below. (When "upper limit/lower limit signal input logic selection" in "intelligent function module switch setting" are default values)

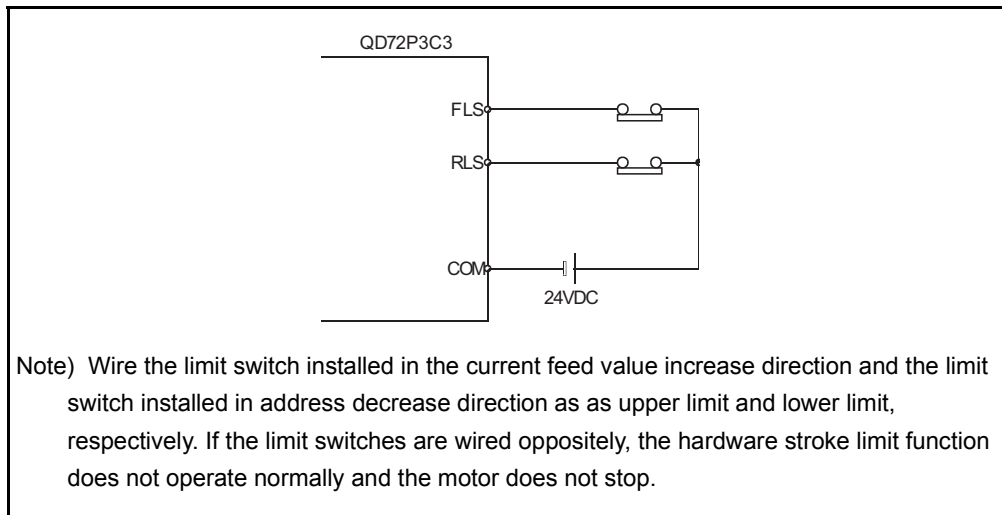

Figure 11.5 Wiring when using the hardware stroke limit function

(3) Precautions during control

- (a) When the workpiece stops at out of controllable range for the QD72P3C3 (outside of the upper limit/lower limit switch) or is stopped by the hardware stroke limit detection, "OPR control" and "positioning control" cannot be started. To resume control, move the workpiece to in the controllable range of the QD72P3C3 with "JOG operation".
- (b) If "upper limit/lower limit logic selection" in "intelligent function module switch setting" are default values, the QD72P3C3 cannot perform positioning control when between FLS (upper limit signal) and COM or RLS (lower limit signal) and COM is open (including the case when they are not wired).

(4) When not using the hardware stroke limit function

When not using the hardware stroke limit function, wire the terminals of the QD72P3C3 upper limit/lower limit signals as the figure below. (When "upper limit/lower limit signal input logic selection" in "intelligent function module switch setting" are default values)

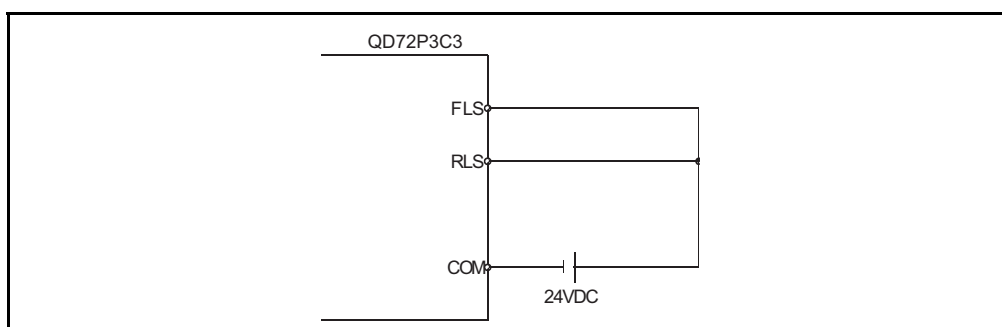

Figure 11.6 Wiring when not using the hardware stroke limit function

11.6 ACC/DEC Process Function

This function adjusts the acceleration/deceleration when OPR control, positioning control or JOG operation is performed.

Adjusting the acceleration/deceleration processing according to used equipment and control enables finer control.

Settable adjustment items regarding acceleration/deceleration, "speed at start", "target speed", "ACC/DEC time", and "ACC/DEC method".

(1) Control contents

(a) Relation among "speed at start", "ACC/DEC time", and "target speed"

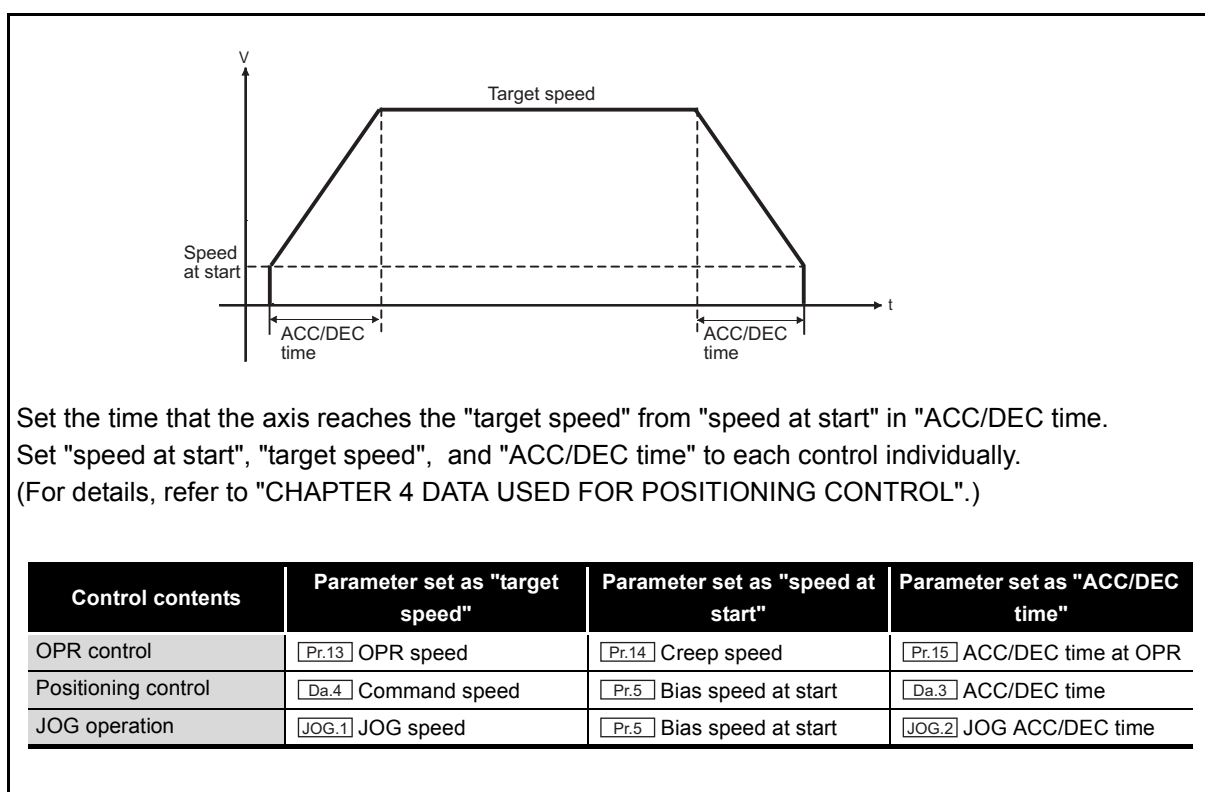

Figure 11.7 Relation among "speed at start", "ACC/DEC time", and "target speed"

(b) Handling of acceleration in the QD72P3C3 and actual ACC/DEC time
 Acceleration at acceleration/deceleration operation is calculated using "ACC/DEC time", "speed at start", "target speed", and "pulse unit".
 However, since acceleration is processed as integer value, time actually taken to acceleration/deceleration"actual ACC/DEC time" may differ from "ACC/DEC time".

POINT

For calculation of "acceleration" and "time actually taken to acceleration/deceleration", refer to the following.

- Section 11.6.1 Calculating the actual ACC/DEC time

(2) Precautions

- (a) When the target speed is 1 (pulse/s), the set ACC/DEC time is ignored.
- (b) If the ACC/DEC pattern which does not have the constant speed part and whose movement amount is small for the ACC/DEC time, the axis does not operate at the set ACC/DEC time. In this case, review the setting contents.

11.6.1 Calculating the actual ACC/DEC time

"Acceleration*" and "time taken to the actual acceleration/deceleration" during acceleration/deceleration operation can be calculated by the "ACC/DEC time calculation function" in GX Configurator-PT.

(1) Calculating using GX Configurator-PT

- (a) Enter parameters required for calculating acceleration into the "Setting" 1. to 4. Parameters entered to the "Setting" 1. to 3. depend on control contents.

Control contents	Parameter entered to 1.	Parameter entered to 2.	Parameter entered to 3.
OPR control	[Pr.13] OPR speed	[Pr.14] Creep speed	[Pr.15] ACC/DEC time at OPR
Positioning control	[Da.4] Command speed	[Pr.5] Bias speed at start	[Da.3] ACC/DEC time
JOG operation	[JOG.1] JOG speed	[Pr.5] Bias speed at start	[JOG.2] JOG ACC/DEC time

Enter "[Pr.4] Speed limit value" for the "Setting" 4.

- (b) Click [Calculation]. Calculation results are displayed in the "Result" 5. to 9.

5. Acceleration	Displays the acceleration calculated according to the "Setting" 1. to 4.
6. Actual acceleration	Displays the rounded value of 5. Acceleration. Actual acceleration/deceleration operation is performed with this acceleration.
Difference (%)	Displays the difference between 5. Acceleration and 6. Actual acceleration. (The displayed value is the difference over 5. Acceleration.)
	Displays the difference between 3. ACC/DEC time and 9. Actual ACC/DEC time (9. - 3.).
9. Actual ACC/DEC time (ms)	Displays the actual ACC/DEC time.

ACC/DEC time calculation Function

QD72P3C3 module processes acceleration(value calculated based on the set value 1. - 4.) as integer. Therefore, the difference might be generated between Actual ACC/DEC time(9.) and ACC/DEC time(3.). An "Actual ACC/DEC time" can be calculated by inputting set value 1. - 4. on this dialog.

Setting

1.Command speed(pps)

2.Bias speed at start(pps)

3.ACC/DEC time(ms)

4.Speed limit value(pps)

Result

5.Acceleration

6.Actual acceleration

7.Difference(%)

8.Difference(ms)

9.Actual ACC/DEC time(ms)

Details

6. is a half-adjust value of 5.
7. and 8. is calculated as follows.
7. = $((5. - 6.) / 6.) * 100.$
8. = 9. - 3.

[Calculation] [Close]

(2) Calculation example of "5.Acceleration" and "9.Actual ACC/DEC time"

Calculating formula for "5. Acceleration" is shown below.

$$5) \text{ Acceleration} = \frac{(1) \text{ Target speed} - 2) \text{ Speed at start}}{3) \text{ ACC/DEC time} \times \text{Pulse unit}^*} \times 8$$

* Pulse unit changes according to the value set to "4. Speed limit value (Pr.4)" as the table below.

" Pr.4 Speed limit value"	1 to 8000	8001 to 32000	32001 to 64000	64001 to 100000
Pulse unit	1-pulse unit	4-pulse unit	8-pulse unit	25-pulse unit

"6. Actual acceleration" is a value rounds "5. Acceleration" to the nearest whole number*.

Therefore, "9. Actual ACC/DEC time" and "3. ACC/DEC time" may differ as shown below.

* However, if "5. Acceleration" is less than 1, "6. Actual acceleration" is rounded up to 1.

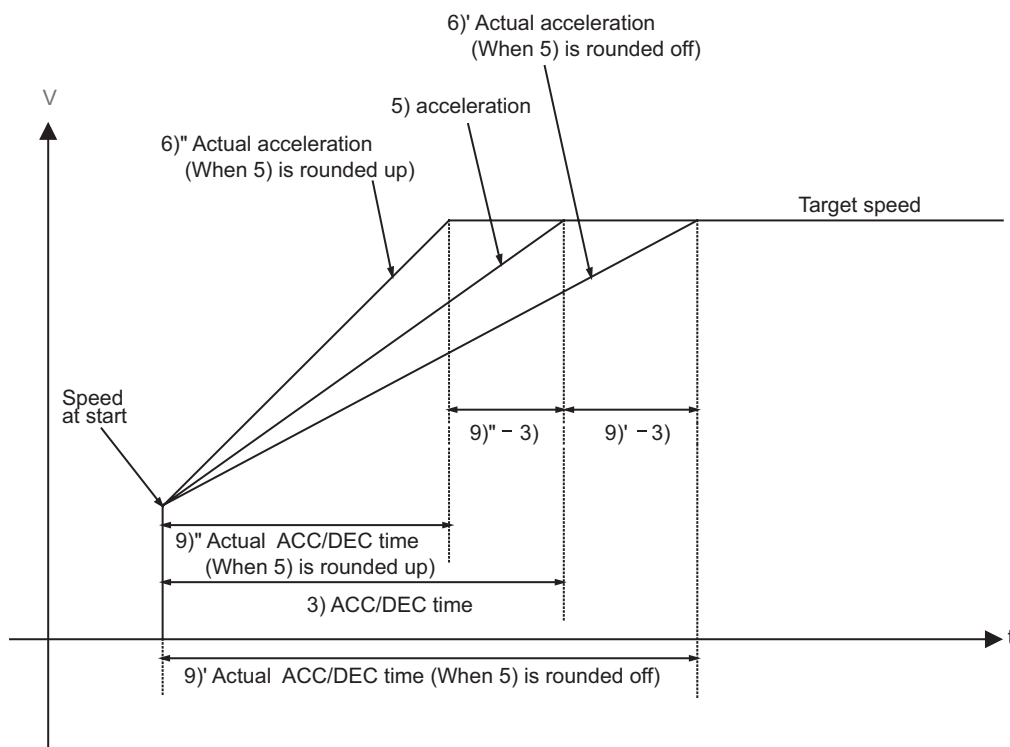

[Calculation example 1: "9. Actual ACC/DEC time" is longer than "3. ACC/DEC time"]

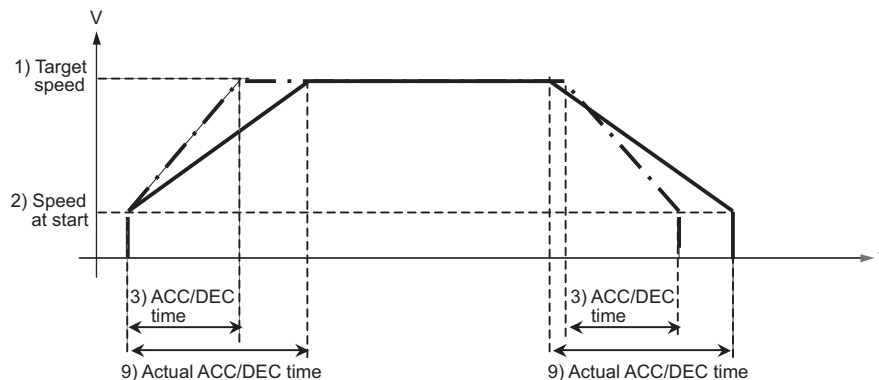

When "1. Target speed" is 100000pps, "2. Speed at start" is 100pps, "3. ACC/DEC time" is 990ms and pulse unit is 25 ("4. Speed limit value (Pr.4)" is 100000pps), "9. Actual ACC/DEC time" is calculated by the following formula.

- 5) Acceleration =
$$\frac{(1) \text{ Target speed} - (2) \text{ Speed at start}}{(3) \text{ ACC/DEC time} \times \text{Pulse unit}} \times 8 = \frac{(100000 - 100) \times 8}{990 \times 25} = 32.290$$

- 6) Actual acceleration = 32

- 7) Difference (difference between acceleration and actual acceleration when using acceleration as the base.) =
$$\frac{(5) \text{ Acceleration} - (6) \text{ Actual acceleration}}{(6) \text{ Actual acceleration}} \times 100$$

$$= \frac{32.290 - 32}{32} \times 100$$

$$= 0.9(\%)$$

- 9) Actual ACC/DEC time =
$$(3) \text{ ACC/DEC time} + \left(\frac{(7) \text{ Difference}}{100} \times (3) \text{ ACC/DEC time} \right)$$

$$= 990 + \left(\frac{0.9}{100} \times 990 \right)$$

$$= 999 \text{ (ms)}$$

Set "speed at start", "target speed", and "ACC/DEC time" to each control individually. (For details, refer to "CHAPTER 4 DATA USED FOR POSITIONING CONTROL".)

Control contents	Parameter set as "target speed"	Parameter set as "speed at start"	Parameter set as "ACC/DEC time"
OPR control	Pr.13 OPR speed	Pr.14 Creep speed	Pr.15 ACC/DEC time at OPR
Positioning control	Da.4 Command speed	Pr.5 Bias speed at start	Da.3 ACC/DEC time
JOG operation	JOg.1 JOG speed	Pr.5 Bias speed at start	JOg.2 JOG ACC/DEC time

[Calculation example 2: "9. Actual ACC/DEC time" is shorter than "3. ACC/DEC time"]

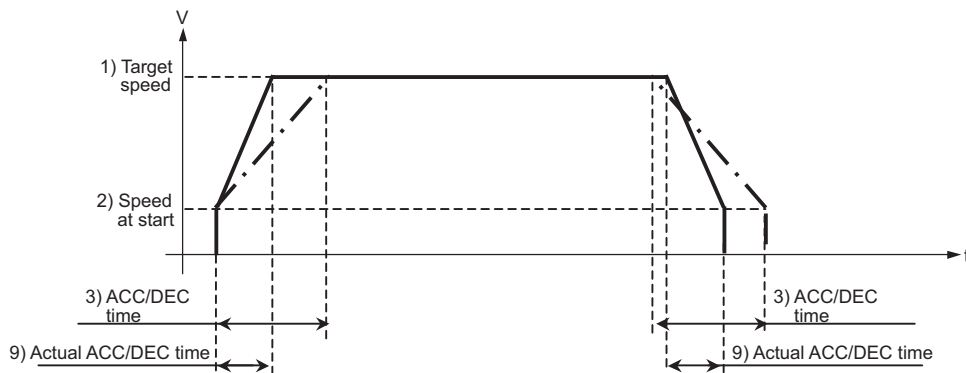

When "1. Target speed" is 100000pps, "2. Speed at start" is 100pps, "3. ACC/DEC time" is 1000ms and pulse unit is 25 ("4. Speed limit value (Pr.4) is 100000pps), "9. Actual ACC/DEC time" is calculated by the following formula.

- 5) Acceleration =
$$\frac{(1) \text{ Target speed} - (2) \text{ Speed at start}}{(3) \text{ ACC/DEC time} \times \text{Pulse unit}} \times 8 = \frac{(100000 - 100) \times 8}{1000 \times 25} = 31.968$$

- 6) Actual acceleration = 32

- 7) Difference (difference between acceleration and actual acceleration when using acceleration as the base.) =
$$\frac{(5) \text{ Acceleration} - (6) \text{ Actual acceleration}}{(6) \text{ Actual acceleration}} \times 100$$

$$= \frac{31.968 - 32}{32} \times 100$$

$$= -0.1(\%)$$

- 8) Actual ACC/DEC time =
$$(3) \text{ ACC/DEC time} + \left(\frac{(7) \text{ Difference}}{100} \times (3) \text{ ACC/DEC time} \right)$$

$$= 1000 + \left(\frac{-0.1}{100} \times 1000 \right)$$

$$= 999 \text{ (ms)}$$

Set "speed at start", "target speed", and "ACC/DEC time" to each control individually. (For details, refer to "CHAPTER 4 DATA USED FOR POSITIONING CONTROL".)

Control contents	Parameter set as "target speed"	Parameter set as "speed at start"	Parameter set as "ACC/DEC time"
OPR control	Pr.13 OPR speed	Pr.14 Creep speed	Pr.15 ACC/DEC time at OPR
Positioning control	Da.4 Command speed	Pr.5 Bias speed at start	Da.3 ACC/DEC time
JOG operation	JOG.1 JOG speed	Pr.5 Bias speed at start	JOG.2 JOG ACC/DEC time

CHAPTER 12 COUNTER FUNCTION

This chapter describes the counter function of the QD72P3C3.

12.1 Outline of Counter Function

12.1.1 Types of pulse input method

There are four kinds of the pulse input methods: CW/CCW pulse input and 2-phase pulse input (1, 2 or 4 multiples).

Select the pulse input method in the "pulse input mode" of the intelligent function module switch on GX Developer. For setting details, refer to Section 5.6.

The following table shows the pulse input methods and count timing.

Pulse input method		Count timing	
CW/CCW	For addition count		Counts on the rising edge (↑) of ϕA .
	For subtraction count		Counts on the rising edge (↑) of ϕB .
1 multiple of 2 phases*2	For addition count		When ϕA is OFF, counts on the falling edge (↓) of ϕB .
	For subtraction count		When ϕB is OFF, counts on the falling edge (↓) of ϕA .
2 multiples of 2 phases*2	For addition count		When ϕA is ON, counts on the rising edge (↑) of ϕB . When ϕA is OFF, counts on the falling edge (↓) of ϕB .
	For subtraction count		When ϕB is ON, counts on the rising edge (↑) of ϕA . When ϕB is OFF, counts on the falling edge (↓) of ϕA .
4 multiples of 2 phases	For addition count		When ϕB is OFF, counts on the rising edge (↑) of ϕA . When ϕB is ON, counts on the falling edge (↓) of ϕA . When ϕA is ON, counts on the rising edge (↑) of ϕB . When ϕA is OFF, counts on the falling edge (↓) of ϕB .
	For subtraction count		When ϕB is ON, counts on the rising edge (↑) of ϕA . When ϕB is OFF, counts on the falling edge (↓) of ϕA . When ϕA is OFF, counts on the rising edge (↑) of ϕB . When ϕA is ON, counts on the falling edge (↓) of ϕB .

☒ IMPORTANT

- * 1: The module may not be able to operate normally if each I/O signal logic is set incorrectly. Pay special attention when changing the setting from the default value.
- * 2: When using the input method of either 1 multiple of 2 phases or 2 multiples of 2 phases, be sure to input 2-phase pulses. With these input methods, pulses are counted according to the changes between phase A and phase B.

12.1.2 Reading count values

Count operation starts when the count enable command (Y1 to Y1E) is turned ON.

Count values are stored to "[Md.3] Count value" in 31-bit signed binary.

Since the contents of "[Md.3] Count value" are automatically updated by count operation, the latest count value can be read from "[Md.3] Count value".

For details of count operation, refer to Section 12.4.

Item	Buffer memory address		
	CH1	CH2	CH3
[Md.3] Count value	74	174	274
	75	175	275

12.1.3 Selecting counter format

Select the linear counter or ring counter in the intelligent function module switch setting of GX Developer.

- For setting details of counter format, refer to Section 5.6.
- For details of linear counter, refer to Section 12.2.
- For details of ring counter, refer to Section 12.3.

12.2 Linear Counter Function

(1) Linear counter operation

When the linear counter is selected, counting is operated in a range between -1073741824 (lower limit value) and 1073741823 (upper limit value).

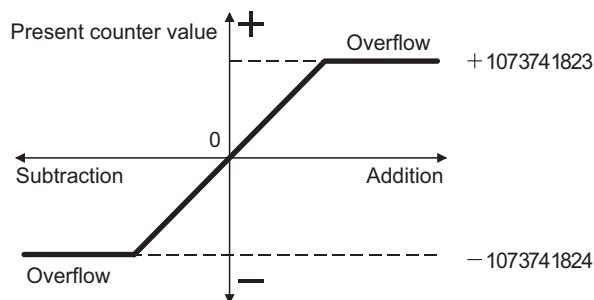

(2) Overflow

- When the linear counter is selected for the counter format, if the present value falls below -1073741824 (lower limit value) in subtraction or exceeds 1073741823 (upper limit value) in addition, an "Overflow" warning (warning code: 27) occurs.
- If an overflow occurs, 1 is stored in the overflow detection flag (Md.7 Status: b3) of the buffer memory, and counting is stopped. Even if a pulse is input in that condition, " Md.3 Count value" does not change from -1073741824 or 1073741823.
- An overflow can be cancelled by presetting the " Md.3 Count value" to the value in the range between -1073741824 and 1073741823.

Executing preset stores 0 in the overflow detection flag (Md.7 Status: b3) of the buffer memory, allowing restart of counting.

Note that the values stored in the " Md.6 Axis/CH Warning code" and the ON status of the Axis/CH warning occurrence signal (X4 to X6) are not reset until the error is reset. Reset the error by turning ON the Axis/CH error reset signal (Y1 to Y3) after counting is restarted by the preset function.

12.3 Ring Counter Function

(1) Ring counter operation

- (a) When the ring counter is selected, counting is repeated within the range between 0 and "[Pr.16] Ring counter upper limit value -1". No overflow occurs when the ring counter is selected.

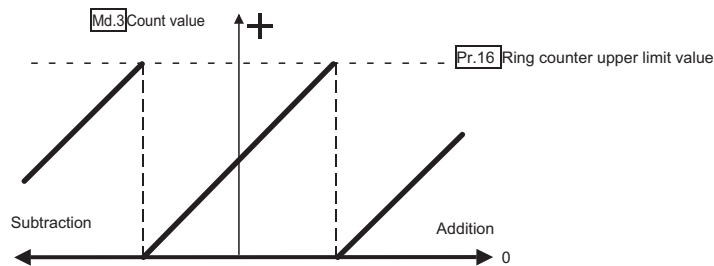

- (b) When the ring counter is selected, the positioning range is from 0 to "[Pr.17] Positioning range upper limit value -1".
- When positioning control is performed in absolute system, the movement amount is limited between 0 to "[Pr.17] Positioning range upper limit value -1".

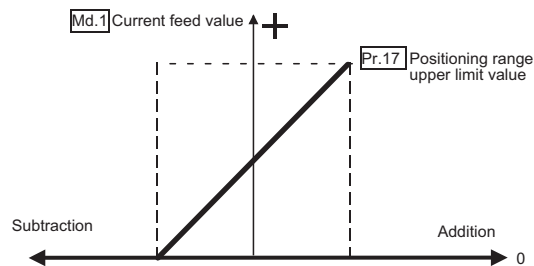

- When positioning control in incremental system, speed control, and JOG operation are performed, the current feed value is repeatedly updated between 0 and "[Pr.17] Positioning range upper limit -1".

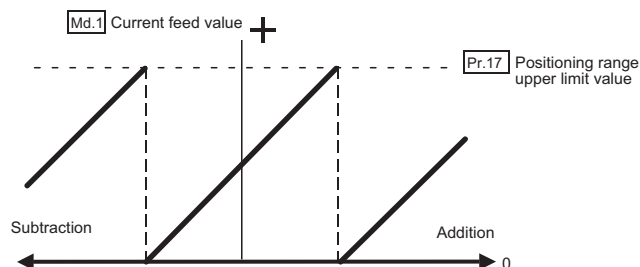

(Example)

By setting the same value in "[Pr.16] Ring counter upper limit value" and "[Pr.17] Positioning range upper limit value", the angle of the rotation target can be controlled, checking the actual position at the same time.

The following shows the operation when controlling a rotation target which rotates once with 3000 pulses.

(Conditions)

"[Pr.16] Ring counter upper limit value"/"[Pr.17] Positioning range upper limit value": 3000,

"[Md.3] Count value"/"[Md.1] Current feed value": 500

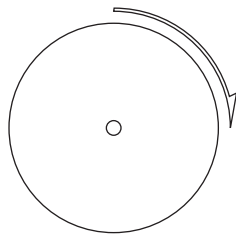

Rotation target which rotates once with 3000pulses

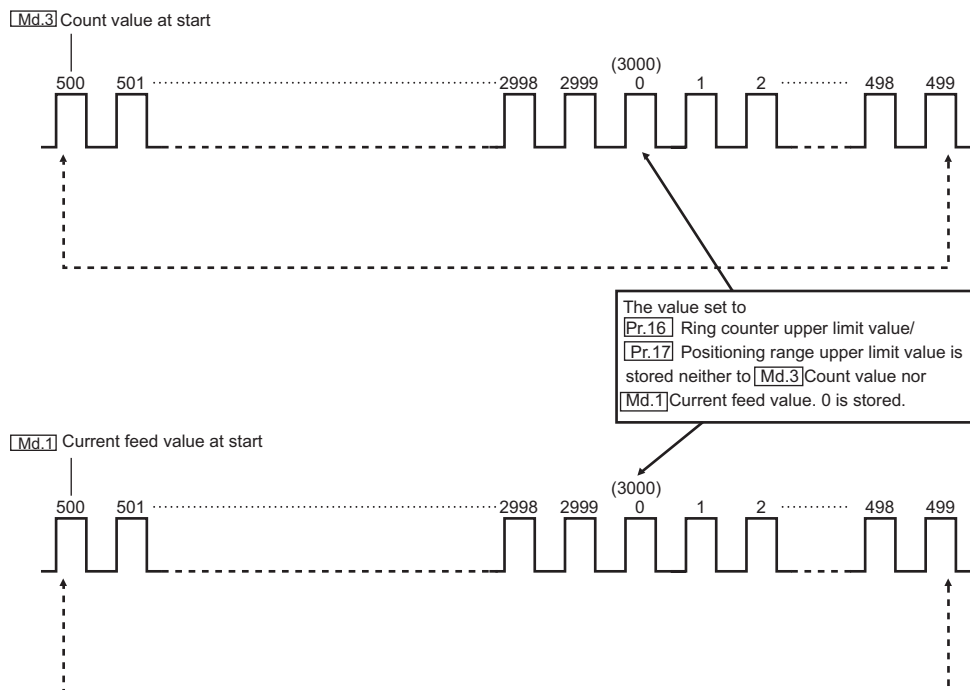

(2) Precautions

(a) When the ring counter is selected, the supported counter functions are limited.

- Preset function: Supported
- Coincidence detection function: Not supported

POINT

When 0 is set to "[Pr.16] Ring counter upper limit value", the counting range is from 0 to 1073741823.

12.4 Count Enable Function

The following shows the relationship between the count enable command (Y1C to Y1E) and "Md.3 Count value".

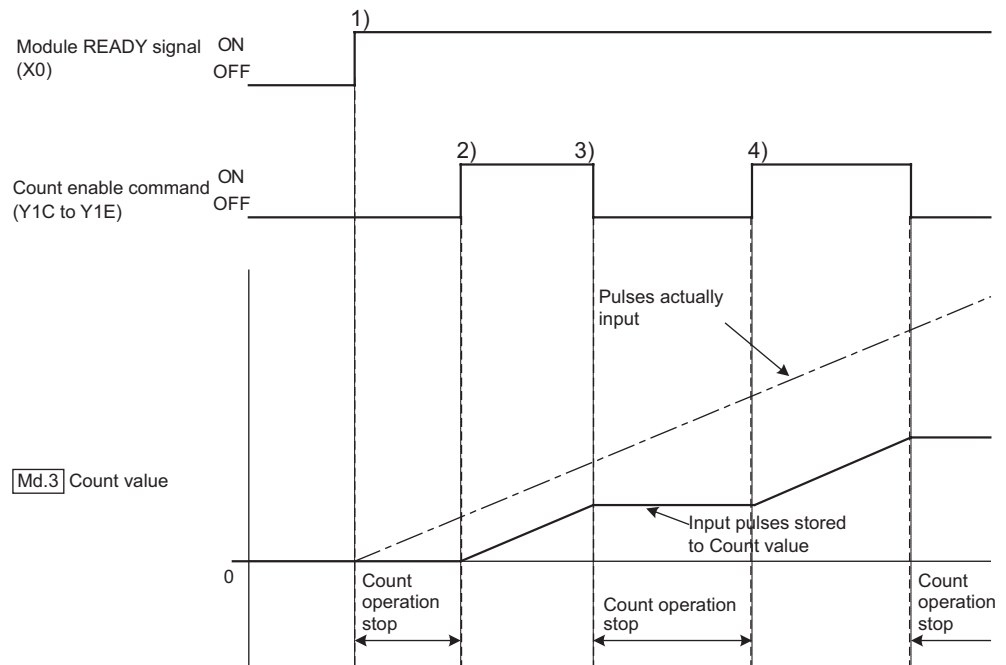

No.	Description
1)	Count operation does not start yet when the module READY signal (X0) turns ON.
2)	Count operation starts when the count enable command (Y1C to Y1E) is turned ON.
3)	Count operation stops when the count enable command (Y1C to Y1E) is turned OFF. This time, "Md.3 Count value" retains the last value before counting has stopped.
4)	Count operation restarts when the count enable command (Y1C to Y1E) is turned ON. "Md.3 Count value" is updated from the retained value.

POINT

When the setting value of "Cd.7 Coincidence detection point setting" is changed, change the count enable command (Y1C to Y1E) from ON to OFF, and again to ON.

12.5 Coincidence Detection Function

This function compares "Md.3 Count value" with a count value set in advance, and outputs signals when the values coincide.

The coincidence detection can be set for each channel in units of one points.

(1) Operation of coincidence detection

To use the coincidence detection function, set "Pr.18 Coincidence detection setting" to "1: Coincidence detection requested".

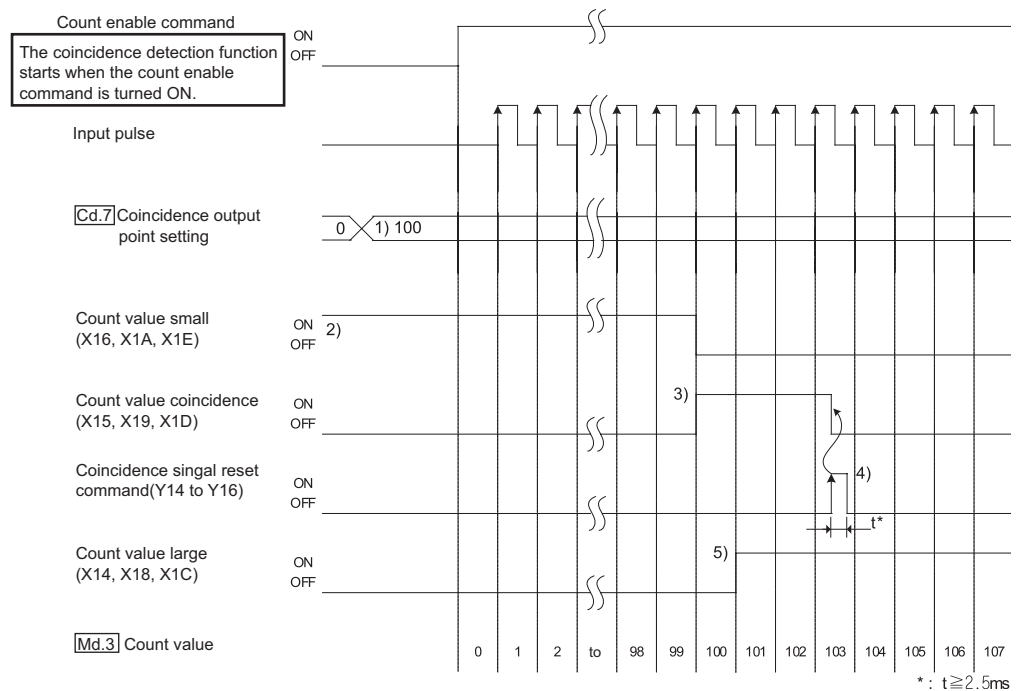

No.	Description
1)	Set the value for detecting coincidence (100) to " <u>Cd.7</u> Coincidence detection point setting" in advance. The coincidence detection starts using the value of " <u>Cd.7</u> Coincidence detection point setting" when the count enable command (Y1C to Y1E) is turned ON.
2)	When " <u>Md.3</u> Count value" is smaller than " <u>Cd.7</u> Coincidence detection point setting", the count value small (X16, X1A, and X1E) turns ON.
3)	When " <u>Md.3</u> Count value" coincides with " <u>Cd.7</u> Coincidence detection point setting", the count value small (X16, X1A, and X1E) turns OFF and the count value coincidence (X15, X19, and X1D) turns ON.
4)	The coincidence signal reset command (Y14 to Y16) is turned ON and the count value coincidence (X15, X19, and X1D) is reset. If the count value coincidence (X15, X19, and X1D) remains ON, the next coincidence signal cannot be output.
5)	When " <u>Md.3</u> Count value" is larger than " <u>Cd.7</u> Coincidence detection point setting", the count value large (X14, X18, and X1C) turns ON.

POINT

- When the first programmable controller CPU READY signal (Y0) is turned ON after power-ON, the count value coincidence (X15, X19, and X1D) turns ON since "Cd.7 Coincidence detection point setting" is set to zero. Therefore, write any value other than zero to "Cd.7 Coincidence detection point setting" and change the count enable command (Y1C to Y1E) from OFF to ON, and again to OFF. Note that the ON time must be 2.5ms or longer.
- The QD72P3C3 internal processing of coincidence detection may cause the count value large (X14, X18, and X1C) or the count value small (X16, X1A, and X1E) to turn ON when the count value coincidence (X15, X19, and X1D) status changes from OFF to ON.

(2) Coincidence detection interrupt function

This function generates an interrupt request to the programmable controller CPU during coincidence detection.

This interrupt request enables the start of interrupt processing programs.

(When using this function with the Q00JCPU/Q00CPU/Q01CPU, select the CPU of function version B or later.)

(a) Up to 16-point interrupt factors (SI) are allowed for a single MELSECNET-Q series intelligent function module.

As shown in the table below, the QD72P3C3 has 3-point interrupt factors (SI) for coincidence detection.

SI No.	Interrupt factor
0	Channel 1: Coincidence detection of coincidence detection point
1	Channel 2: Coincidence detection of coincidence detection point
2	Channel 3: Coincidence detection of coincidence detection point
3 to 15	Reserved

Timing of interrupt signal generation

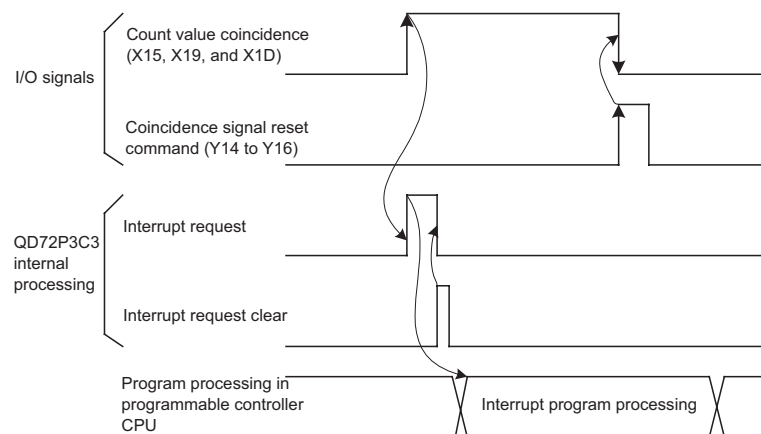

- (d) The following two methods are available for using particular SI numbers only.
- 1) Using the interrupt pointer setting with parameters
Only the interrupt factors, starting from the "Start SI No." for the number set at "Interrupt pointer No. of module" in the [Intelligent function module interrupt pointer setting] screen, are used.
For example, when the "Start SI No." and "Interrupt pointer No. of module" are set to 1 and 2 respectively, only SI 1 and 2 can be used.
The interrupt function is not used if the interrupt pointer setting with parameters has not been made.
 - 2) Using the IMASK instruction in the sequence program
With the IMASK instruction, an interrupt enable/disable status (interrupt mask) can be set for each interrupt pointer number.
For details of the IMASK instruction, refer to the MELSEC-Q/L Programming Manual (Common Instructions).

☒ POINT

- A coincidence detection interrupt occurs when the count value coincidence signal rises (from OFF to ON).
This means that, unless the count value coincidence signal is turned OFF by performing coincidence signal reset, the next interrupt request is not issued.
- When the interrupt occurrence interval is within "interrupt delay time (approx. 100 to 200 μ s) + interrupt program processing time", "Watch dog timer error" of the CPU may occur and/or an interrupt request may not be detected. For details, refer to the MELSEC-Q/L Programming Manual (Common Instructions).

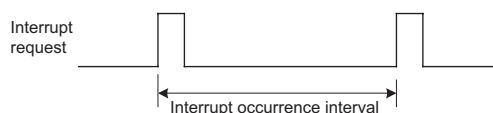

12.6 Preset Function

This function replaces "**[Md.3]** Count value" to an arbitrary value.
 An arbitrary value to be replaced is called a preset value.
 This function is used to start counting pulses from the preset value.

(1) Preset function operation

The preset function is activated by turning the preset command (Y18 to Y1A) ON.

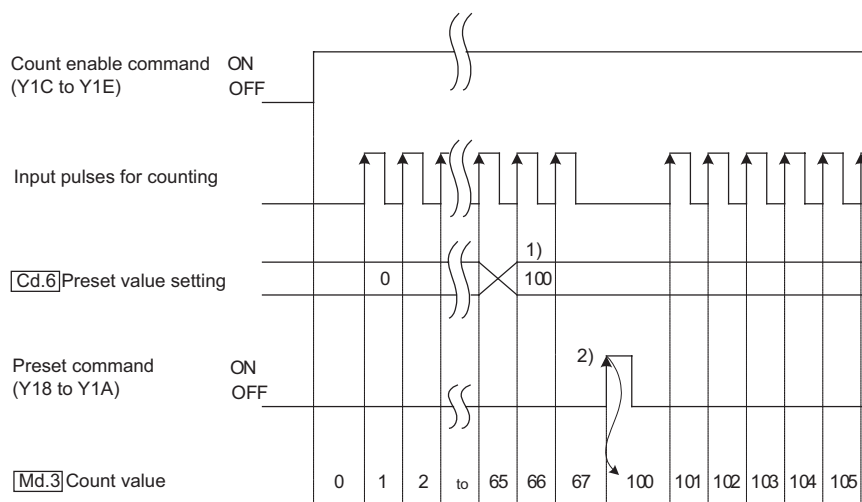

No.	Description
1)	Write an arbitrary value to " [Cd.6] Preset value setting".
2)	When the preset command (Y18 to Y1A) rises (from OFF to ON), a value in " [Cd.6] Preset value setting" is preset to " [Md.3] Count value".

POINT

The preset function can be executed regardless of the ON/OFF status of the count enable command (Y1C to Y1E).

12.7 Current Feed Value, Count Value Simultaneous Change Function

This function stores the same value in "**[Md.1]** Current feed value" and "**[Md.3]** Count value" by performing current value change or preset function.

For details of current value change, refer to "Section 9.2.4 Current value change".

For details of preset function, refer to "Section 12.6 Preset Function".

(1) Operation pattern

To use this function, an operation pattern needs to be set for "**[Pr.9]** Current feed value, count value simultaneous change function selection".

The operating conditions and value stored to both "**[Md.1]** Current feed value" and "**[Md.3]** Count value" depend on the operation pattern.

(Refer to the table below.)

Setting value of [Pr.9]	Operating condition	Stored value	
		[Md.1] Current feed value	[Md.3] Count value
1: Count value changed together at current value change	Current value change execution (Positioning start ON)	[Da.5] Positioning address/movement amount	[Da.5] Positioning address/movement amount
	Preset command ON	-	[Cd.6] Preset value setting
2: Current feed value changed together at preset	Current value change execution (Positioning start ON)	[Da.5] Positioning address/movement amount	-
	Preset command ON	[Cd.6] Preset value setting	[Cd.6] Preset value setting
3: Values changed both at current value change and at preset	Current value change execution (Positioning start ON)	[Da.5] Positioning address/movement amount	[Da.5] Positioning address/movement amount
	Preset command ON	[Cd.6] Preset value setting	[Cd.6] Preset value setting

(a) Count value changed together at current value change (Setting value of **[Pr.9]** : 1)

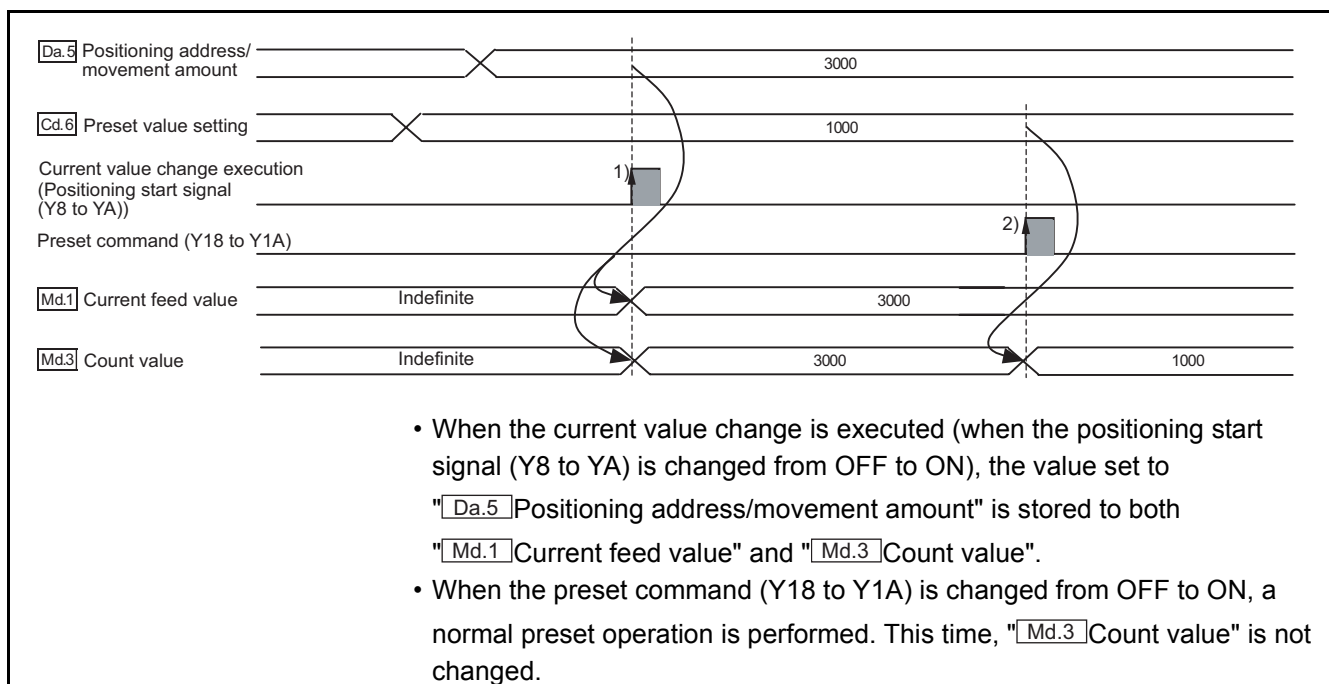

- When the current value change is executed (when the positioning start signal (Y8 to YA) is changed from OFF to ON), the value set to "**[Da.5]** Positioning address/movement amount" is stored to both "**[Md.1]** Current feed value" and "**[Md.3]** Count value".
- When the preset command (Y18 to Y1A) is changed from OFF to ON, a normal preset operation is performed. This time, "**[Md.3]** Count value" is not changed.

(b) Current feed value changed together at preset (Setting value of $\boxed{\text{Pr.9}}$: 2)

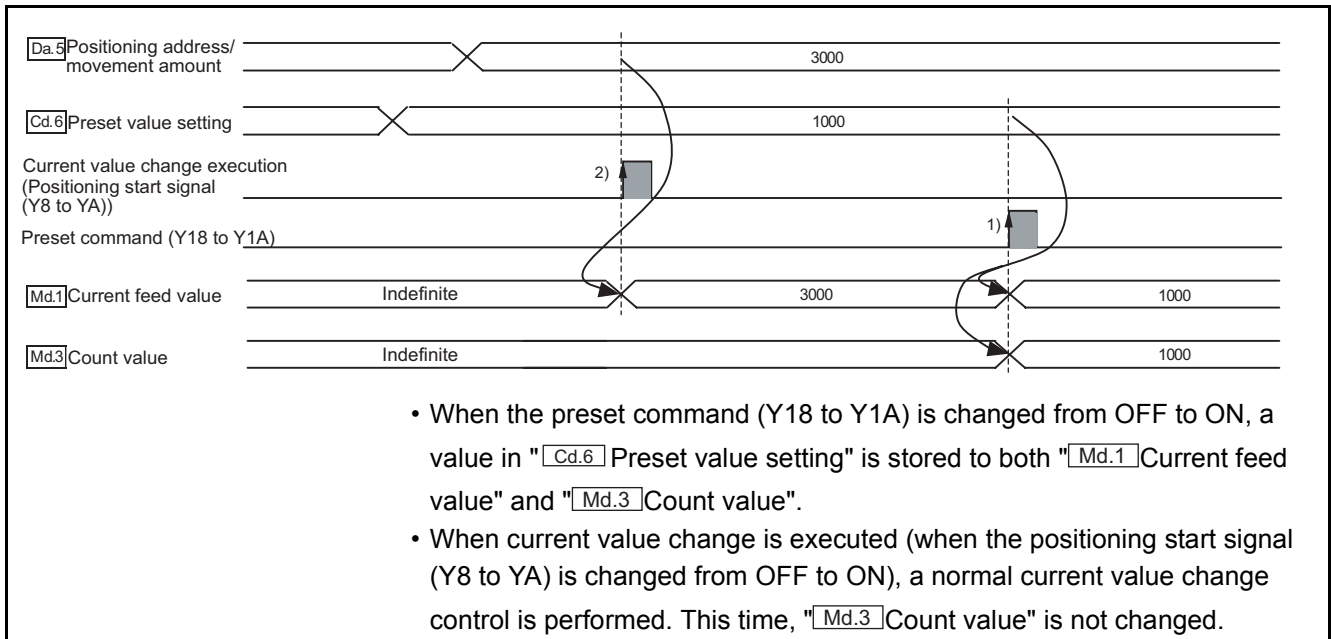

- When the preset command (Y18 to Y1A) is changed from OFF to ON, a value in " $\boxed{\text{Cd.6}}$ Preset value setting" is stored to both " $\boxed{\text{Md.1}}$ Current feed value" and " $\boxed{\text{Md.3}}$ Count value".
- When current value change is executed (when the positioning start signal (Y8 to YA) is changed from OFF to ON), a normal current value change control is performed. This time, " $\boxed{\text{Md.3}}$ Count value" is not changed.

(c) 3: Values changed both at current value change and at preset (Setting value of $\boxed{\text{Pr.9}}$: 3)

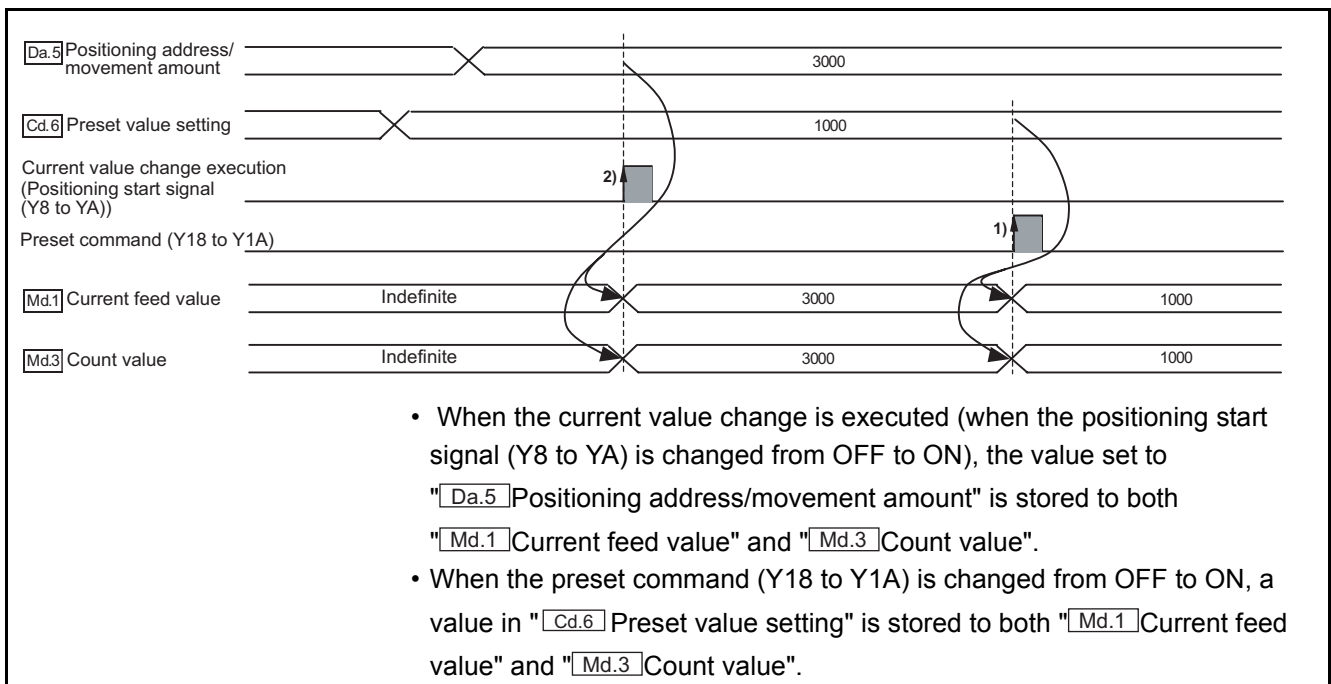

- When the current value change is executed (when the positioning start signal (Y8 to YA) is changed from OFF to ON), the value set to " $\boxed{\text{Da.5}}$ Positioning address/movement amount" is stored to both " $\boxed{\text{Md.1}}$ Current feed value" and " $\boxed{\text{Md.3}}$ Count value".
- When the preset command (Y18 to Y1A) is changed from OFF to ON, a value in " $\boxed{\text{Cd.6}}$ Preset value setting" is stored to both " $\boxed{\text{Md.1}}$ Current feed value" and " $\boxed{\text{Md.3}}$ Count value".

(2) Precautions

" $\boxed{\text{Md.1}}$ Current feed value" is not changed by the preset command (Y18 to Y1A) during positioning control.

When " $\boxed{\text{Pr.9}}$ Current feed value, count value simultaneous change function selection" is set to either "2: Current feed value changed together at preset" or "3: Values changed both at current value change and at preset", a warning "Preset disabled" (warning code: 23) occurs when the preset command (Y18 to Y1A) is changed to ON during positioning control.

☒ POINT

The current feed value, count value simultaneous change function can be executed regardless of the ON/OFF status of the count enable command (Y1C to Y1E).

12.8 Response Delay Time

When using the counter function, response delay time needs to be considered.

(1) Operation and control affected by response delay time

Response delay time is the maximum time to perform the following operation and control.

- (a) Time before count operation starts after the CH□ count enable command (Y1C to Y1E) is turned ON.
- (b) Time before the value in the "Md.3 Count value" is updated after the CH□ preset command (Y18 to Y1A) is turned ON.

(2) Response delay time

Response delay time is calculated by the following formula:

$$\text{Response delay time} = \text{Scan time of sequence program} + \left(\text{Control cycle (2.5ms) of QD72P3C3} \times 2 \right) \text{ [ms]}$$

- (a) Scan time of sequence program
Scan time affects the delay of I/O signals.
The use of direct access inputs (DX) and direct access outputs (DY) can minimize the delay.
- (b) Control cycle (2.5ms) of QD72P3C3
Up to 5ms (Control cycle (2.5ms) of QD72P3C3 × 2) of delay occurs during the time when the QD72P3C3 reads the output signal and buffer memory updated by the sequence program and completes processing.

CHAPTER13 COMMON FUNCTION

This chapter describes details of the common function of the QD72P3C3.

13.1 Outline of Common Function

"Common function" is the generic term for functions operable as necessary, regardless of the control method.

These common functions can be executed using GX Developer.

For details of GX Developer, refer to the GX Developer Operating Manual.

The following table shows the details of "common function".

Common function	Description	Operating method
External I/O signal logic switching	This function changes the external I/O signal logic to match the device connected to the QD72P3C3.	Set the switches on the [I/O assignment] tab in the [Qn[H] Parameter] screen of GX Developer. (Intelligent function module switch)
External I/O signal monitor	This function monitors the external I/O signal status.	Monitors the external I/O signal information on the [Module's Detailed Information] screen, which can be displayed from the [System Monitor] screen of GX Developer.

13.2 External I/O Signal Logic Switching Function

This function changes the external I/O signal logic to match the device connected to the QD72P3C3.

The following table shows the external I/O signals whose logic is switchable.

I/O classification	Signal name	Symbol	Remarks
Input	Zero signal	PG0□	□ of the symbol indicates the axis or channel number (1 to 3).
	Near-point dog signal	DOG□	
	Upper/Lower limit signal	FLS□, RLS□	
Output	Pulse output F, pulse output R	PULSE F□, PULSE R□	
	Deviation counter clear	CLEAR□	

(1) Setting contents

Make settings at "Switch setting" (for intelligent function module) on the [I/O assignment] tab in the [PLC Parameter] screen of GX Developer. For details of the settings, refer to "Section 5.6 Intelligent Function Module Switch Setting".

(2) Precautions for setting

- (a) The switch settings become effective after power-ON or programmable controller CPU reset.
The settings cannot be changed during operation.
- (b) The module may not be able to operate normally if each I/O signal logic is set incorrectly.
Before setting, check the specifications of the device to be used.

13.3 External I/O Signal Monitor Function

This function monitors the module information, external I/O signal information, and intelligent function module switch setting status on the screen displayed by clicking the "H/W Information" button on the [Module's Detailed Information] screen, which can be displayed from the [System Monitor] screen of GX Developer (SW7D5C-GPPW-E or later).

[Setting procedure]

[Diagnostics] → [System monitor] → select "QD72P3C3" → [Module's Detailed Information...] →

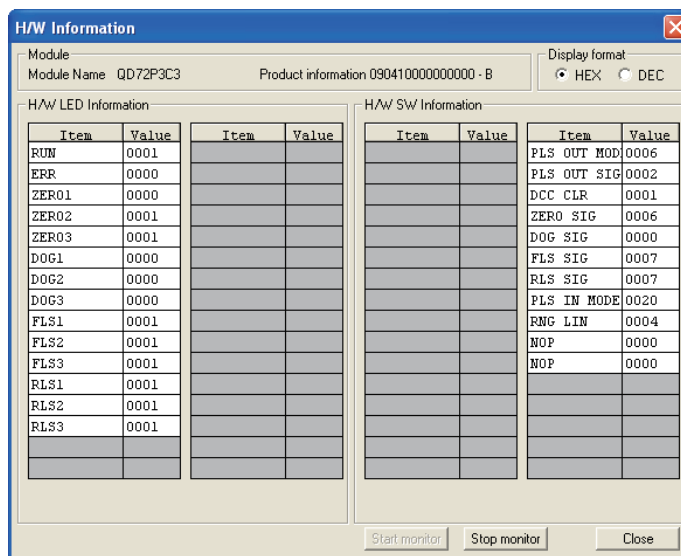

[H/W LED Information]

The following information is displayed at "H/W LED Information" on the [H/W Information] screen.

Item	Signal name	Value
RUN	"RUN" LED of the QD72P3C3	0: The LED is OFF.
ERR.	"ERR." LED of the QD72P3C3	1: The LED is ON or flashing.
ZERO1	Zero signal of Axis 1	0: OFF, 1: ON
ZERO2	Zero signal of Axis 2	
ZERO3	Zero signal of Axis 3	
DOG1	Near-point dog signal of Axis 1	
DOG2	Near-point dog signal of Axis 2	
DOG3	Near-point dog signal of Axis 3	
FLS1	Upper limit signal of Axis 1	
FLS2	Upper limit signal of Axis 2	
FLS3	Upper limit signal of Axis 3	
RLS1	Lower limit signal of Axis 1	
RLS2	Lower limit signal of Axis 2	
RLS3	Lower limit signal of Axis 3	

[H/W SW Information]

The setting status of the intelligent function module switches is displayed.

Item	Signal name	Corresponding switch		Value
PLS OUT MODE	Pulse output mode	Switch 1	0 to 2 bits	For details, refer to "Section 5.6 Intelligent Function Module Switch Setting".
PLS OUT SIG	Pulse output logic selection		4 to 6 bits	
DCC CLR	Deviation counter clear output logic selection		8 to 10 bits	
ZERO SIG	Zero signal input logic selection		12 to 14 bits	
DOG SIG	Near-point dog signal input logic selection	Switch 2	0 to 2 bits	
FLS SIG	Lower limit signal input logic selection		4 to 6 bits	
RLS SIG	Upper limit signal input logic selection		8 to 10 bits	
PLS IN MODE	Pulse input mode	Switch 3	0 to 5 bits	
RNF LIN	Counter format		8 to 10 bits	
NOP	-	Switch 4		
NOP	-	Switch 5		

CHAPTER 14 DEDICATED INSTRUCTIONS

14.1 Dedicated Instruction List and Applicable Devices

(1) Dedicated instruction list

Application	Dedicated instruction	Description	Reference
Positioning start	ZP.PSTRT□	Selects positioning control, machine OPR control, and fast OPR control for the specified axis of the QD72P3C3 and starts the control.	Section 14.3
Direct positioning start	ZP.DSTRT□	Sets the positioning data to the specified axis of the QD72P3C3 and starts the positioning control.	Section 14.4
Speed change	ZP.SPCHG□	Changes the speed of the specified axis of the QD72P3C3 by setting the speed changing parameters.	Section 14.5

(2) Applicable device

The following table shows the devices applicable to the dedicated instructions.

Internal device		File register	Constant
Bit*	Word		
X,Y,M,L,F,V,B	T,ST,C,D,W	R,ZR	-

* Word device bit specification can be used as bit data.
 Word device bit can be specified as "word device.bit number".
 (Specify the bit number in hexadecimal.)
 For example, bit 10 of D0 is specified as "D0.A".
 Note, however, that timers (T), retentive timers (ST), and counters (C) are not subject to bit specification.

14.2 Interlock for Dedicated Instruction Execution

Dedicated instructions cannot be executed to different axes simultaneously. If that occurs, the second and subsequent instructions are ignored due to an interlock of the programmable controller CPU. (No error occurs.)

The following shows the timing of interlock for the positioning start dedicated instruction (ZP.PSTRT□).

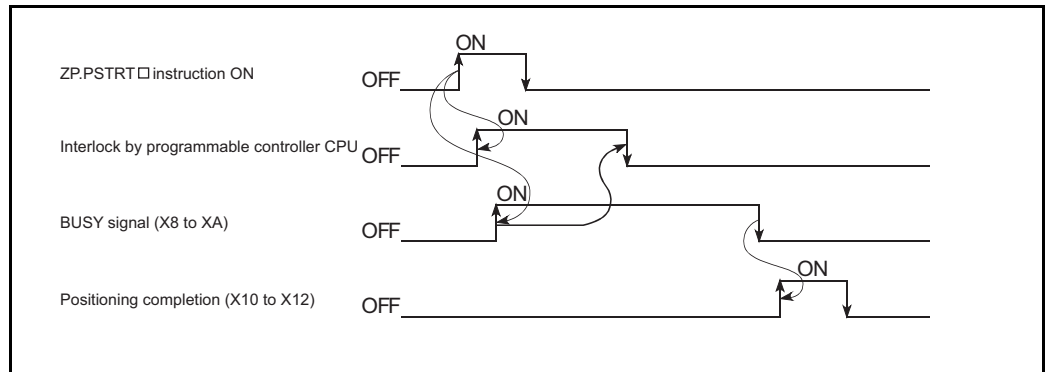

14.3 ZP.PSTRT1, ZP.PSTRT2, ZP.PSTRT3

Selects the start method (positioning control, machine OPR control or fast OPR control) for the specified axis and starts the positioning control.

Setting data	Applicable device								
	Internal device		File register	Link direct device J□\□		Intelligent function module device U□\G□	Index register Zn	Constant	Other
	Bit	Word		Bit	Word			K, H, \$	
(S)	-	○					-	-	
(D)	○	○	-				-	-	

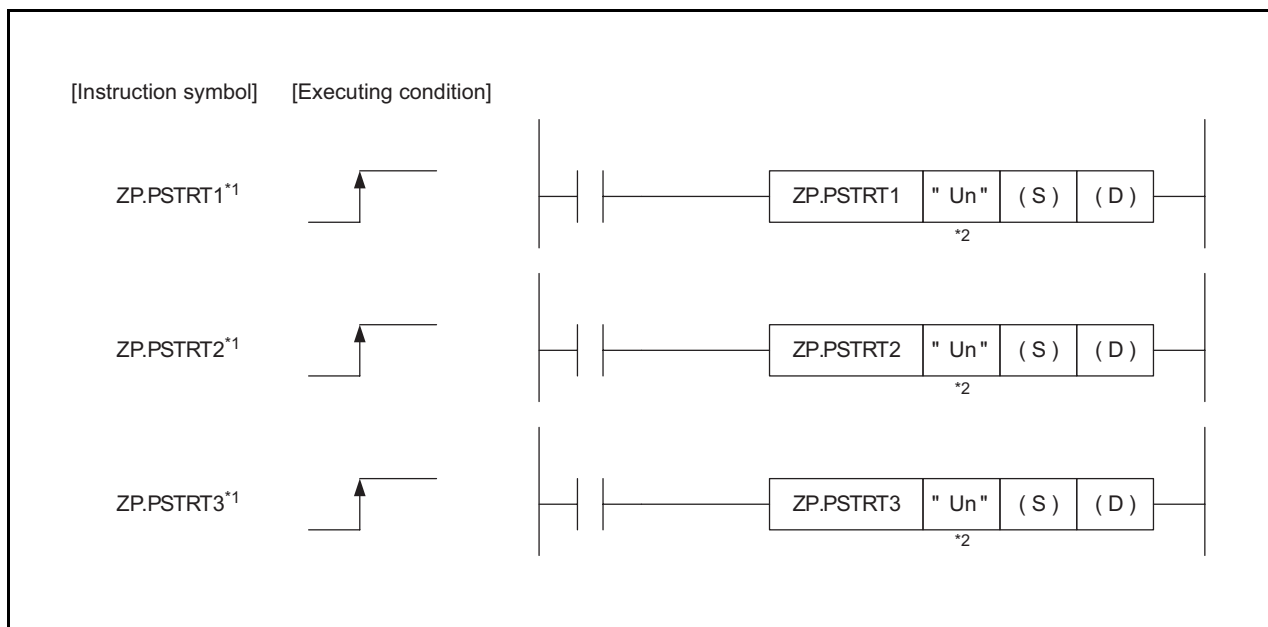

* 1 When describing shared information for ZP.PSTRT1, ZP.PSTRT2, and ZP.PSTRT3, "ZP.PSTRT□" is used.

* 2 If the originating station is a Basic model QCPU (function version B or later), or Universal model QCPU, "" (double quotation) of the first argument can be omitted.

(1) Setting data

Setting data	Description	Set by* ³	Data type
"Un"	Start I/O number of the QD72P3C3 (00 to FD: First two digits when I/O signals are expressed in 3-digit)	User	1 bits
(S)	Start number of the device in which control data is stored	-	Device
(D)	Start number of the bit device to be turned ON for one scan upon completion of the instruction ((D)+1) also turns ON at error completion.	System	Bit

* 3 Local devices and file registers for each program cannot be used for setting data.

(2) Control data

Device	Item	Setting data	Setting range	Set by ^{*1}
(S) +0	System area	-	-	-
(S) +1	Completion status	Stores the status at completion. •0: Normal completion •Other than 0: Error completion (Error code) ^{*2}	-	System
(S) +2	Start number	Specifies the start number to start the control with the ZP.PSTRT□ instruction. •Positioning control: 0 •Machine OPR control: 9000 •Fast OPR control: 9001	0, 9000, 9001	User

* 1 The setting side indicates the following:

- User: Data stored by the user at dedicated instruction execution.
- System: Data stored by the programmable controller CPU at dedicated instruction completion.

* 2 For details of error code at error completion, refer to "Section 15.3".

(3) Function

- (a) Starts the positioning control of the target axis (see below).
 - ZP.PSTRT1: Axis 1
 - ZP.PSTRT2: Axis 2
 - ZP.PSTRT3: Axis 3
- (b) Positioning control and OPR control are started by specifying either 0, 9000 or 9001 at "Start number" of ((S) +2).
- (c) Completion status of the ZP.PSTRT□ instruction can be checked by the completion device ((D) +0) and ((D) +1).
 - 1) Completion device ((D) +0)
Turns ON at END processing in the scan where the ZP.PSTRT□ instruction is completed, and turns OFF at the next END processing.
 - 2) Completion status display device ((D) +1)
Turns ON/OFF according to the status when the ZP.PSTRT□ instruction is completed.
 - Normal completion: Remains OFF.
 - Error completion: Turns ON at END processing in the scan where the ZP.PSTRT□ instruction is completed, and turns OFF at the next END processing. (Same ON/OFF operation as a completion device.)

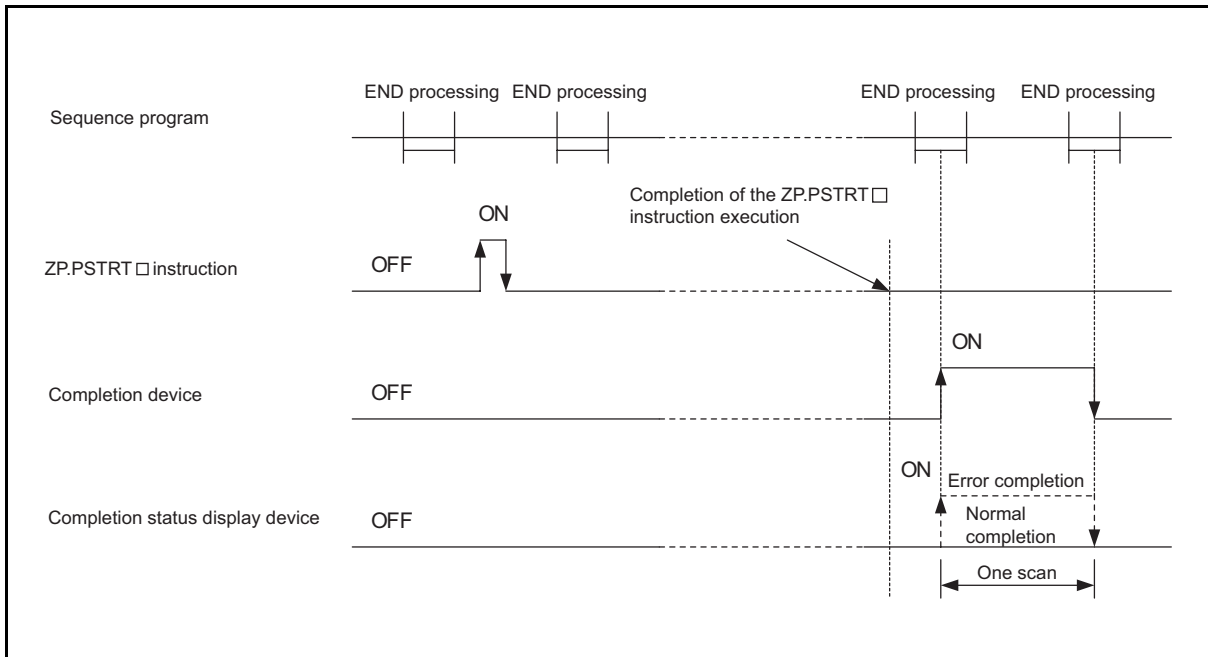

(4) Error

At error completion of the ZP.PSTRT□ instruction, the error completion signal ((D) +1) turns ON and the error code is stored in the completion status ((S) +1). Refer to the error code list in Section 15.2.1, check the error and take corrective action.

(5) Precautions

- (a) When the positioning control is started with the ZP.PSTRT□ instruction, the positioning start signal (Y8 to YA) and the start complete signal (X8 to XA) do not turn ON.
Check the positioning control operation status with the ZP.PSTRT□ start command and the BUSY signal (X8 to XA).
- (b) After the control has been started with the ZP.PSTRT□ instruction, if the stop command is entered without completing positioning, the completion device (D) turns ON for one scan and the ZP.PSTRT□ instruction execution ends.
- (c) The ZP.PSTRT□ instruction can be executed while the module READY signal (X0) is ON. Even though the ZP.PSTRT□ instruction execution is requested while the module READY signal (X0) is OFF, the instruction is not executed.
Before executing the ZP.PSTRT□ instruction, turn ON the programmable controller CPU READY signal (Y0) and the module READY signal (X0).
- (d) When the remote I/O station (Q corresponding MELSECNET/H network remote I/O module) is used, this dedicated instruction (ZP.PSTRT□) cannot be used.
- (e) When the ZP.PSTRT□ instruction is executed with other than 0, 9000, and 9001 set for "Start number"(device: (S) +2) of the control data, "Dedicated instruction error" (error code: 804) occurs and the positioning control cannot be started.

14 DEDICATED INSTRUCTIONS

The program example when a dedicated instruction is not used

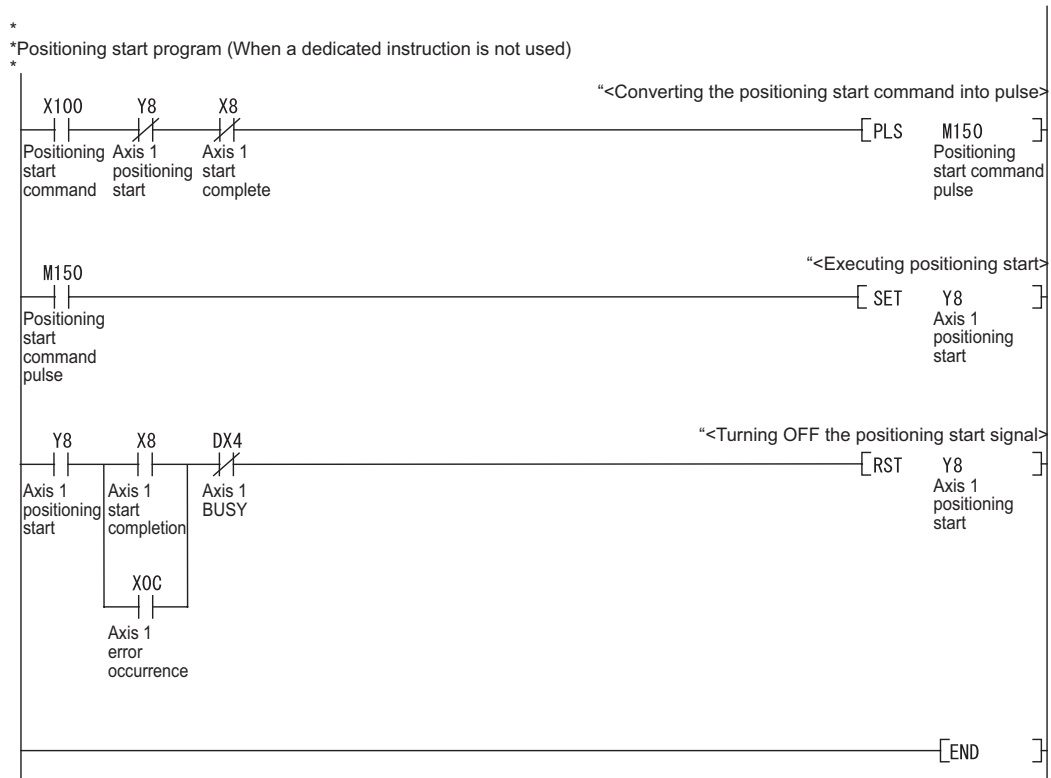

14.4 ZP.DSTRT1, ZP.DSTRT2, ZP.DSTRT3

Sets the positioning data to the specified axis of the QD72P3C3 and starts the positioning control.

Setting data	Applicable device								
	Internal device		File register	Link direct device J□\□		Intelligent function module device U□\G□	Index register Zn	Constant K, H, \$	Other
	Bit	Word		Bit	Word				
(S)	-	○					-	-	
(D)	○	-	-				-	-	

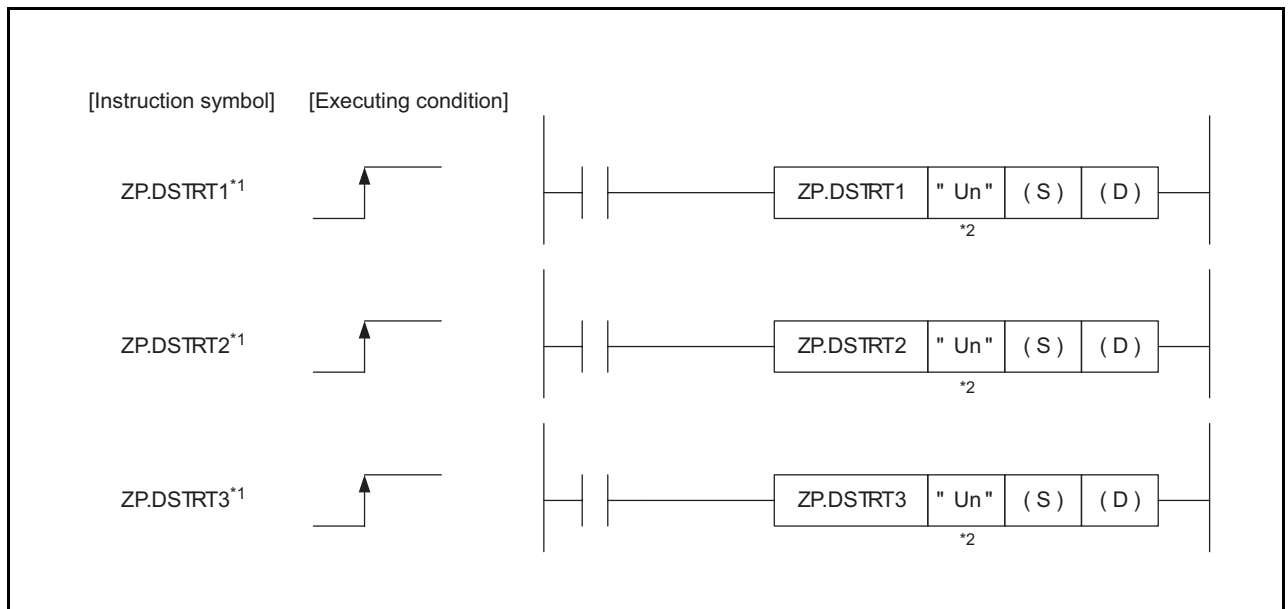

* 1 When describing shared information for ZP.DSTRT1, ZP.DSTRT2, and ZP.DSTRT3, "ZP.DSTRT□" is used.

* 2 If the originating station is a Basic model QCPU (function version B or later), or Universal model QCPU, "" (double quotation) of the first argument can be omitted.

(1) Setting data

Setting data	Description	Set by ^{*3}	Data type
"Un"	Start I/O number of the QD72P3C3 (00 to FD: First two digits when I/O signals are expressed in 3-digit)	User	BIN 16 bit
(S)	Start number of the device in which control data is stored.	-	Device
(D)	Start number of the bit device to be turned ON for one scan upon completion of the instruction ((D)+1) also turns ON at error completion.	System	Bit

* 3 Local devices and file registers for each program cannot be used for setting data.

(2) Control data

Device	Item	Setting data	Setting range	Set by ^{*1}
(S) +0	System area	-	-	-
(S) +1	Completion status	Stores the status at completion. •0: Normal completion •Other than 0: Error completion (Error code) ^{*2}	-	System
(S) +2	Control method	Specifies the control method to start the control with the ZP.DSTRT□ instruction. •1-axis linear control (ABS): 1 •1-axis linear control (INC): 2 •Speed control (Forward run): 3 •Speed control (Reverse run): 4 •Current value change: 5	1 to 5	User
(S) +3	ACC/DEC time	Specifies the ACC/DEC time to perform positioning control with the ZP.DSTRT□ instruction.	1 to 5000 (ms)	User
(S) +4	Command speed	•Specifies the command speed to perform positioning control with the ZP.DSTRT□ instruction.	1 to 100000 (pulse/s)	User
(S) +5				
(S) +6	Positioning address/movement amount	Specifies the positioning address/movement amount to perform positioning control with the ZP.DSTRT□ instruction.	-1073741824 to 1073741823	User
(S) +7		Specifies the change value when performing current value change.		

* 1 The setting side indicates the following:

- User: Data stored by the user at dedicated instruction execution.
- System: Data stored by the programmable controller CPU at dedicated instruction completion.

* 2 For details of error code at error completion, refer to "Section 15.3".

(3) Function

- (a) Sets the positioning data to the specified axis of the QD72P3C3 and starts the positioning control.

Note that the setting value for "Cd.5 Start method" is ignored when this instruction is executed.

- ZP.DSTRT1: Axis 1
- ZP.DSTRT2: Axis 2
- ZP.DSTRT3: Axis 3

- (b) Positioning control can be started with a desired control method by specifying the value at "Control method" of ((S) +2).
- (c) Completion status of the ZP.DSTRT□ instruction can be checked by the completion device ((D) +0) and ((D) +1).

- 1) Completion device ((D) +0)
Turns ON at END processing in the scan where the ZP.DSTRT□ instruction is completed, and turns OFF at the next END processing.
- 2) Completion status display device ((D) +1)
Turns ON/OFF according to the status when the ZP.DSTRT□ instruction is completed.
 - Normal completion: Remains OFF.
 - Error completion: Turns ON at END processing in the scan where the ZP.DSTRT□ instruction is completed, and turns OFF at the next END processing. (Same ON/OFF operation as a completion device.)

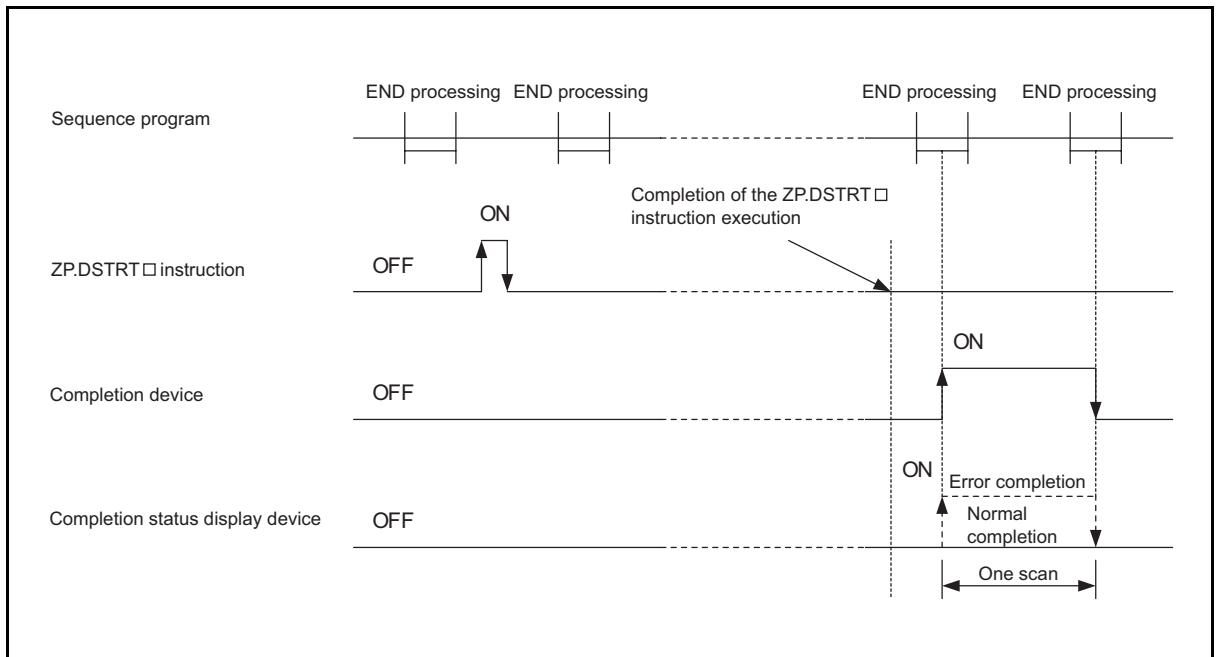

(4) Error

At error completion of the ZP.DSTRT□ instruction, the error completion signal ((D) +1) turns ON and the error code is stored in the completion status ((S) +1). Refer to the error code list in Section 15.2.1, check the error and take corrective action.

(5) Precautions

- (a) When the positioning control is started with the ZP.DSTRT□ instruction, the positioning start signal (Y8 to YA) and the start complete signal (X8 to XA) do not turn ON.
Check the positioning control operation status with the ZP.DSTRT□ start command and the BUSY signal (X8 to XA).
If the "Command speed" of ((S) +4, (S) +5) exceeds the speed limit value, an operation is performed with the speed limit value. If the "Command speed" is lower than the bias speed, an operation is performed with the bias speed.
- (b) After the control has been started with the ZP.DSTRT□ instruction, if the stop command is entered without completing positioning, the completion device (D) turns ON for one scan and the ZP.DSTRT□ instruction execution ends.

- (c) The ZP.DSTRT□ instruction can be executed while the module READY signal (X0) is ON. Even though the ZP.DSTRT□ instruction execution is requested while the module READY signal (X0) is OFF, the instruction is not executed. Before executing the ZP.DSTRT□ instruction, turn ON the programmable controller CPU READY signal (Y0) and the module READY signal (X0).
- (d) When the remote I/O station (Q corresponding MELSECNET/H network remote I/O module) is used, this dedicated instruction (ZP.DSTRT□) cannot be used.
- (e) In the following cases, "Dedicated instruction error" (error code: 804) occurs when the ZP.DSTRT□ instruction is executed, and the positioning control cannot be started.
 - The value other than 1 to 5 is set for "Control method" (device: (S) +2) of the control data.
 - The value outside of the range between 1 and 5000 is set for "ACC/DEC time" (device: (S) +3) of the control data.
 - The value outside of the range between -1073741824 and 1073741823 is set for "Positioning address/movement amount" (device: (S) +6, (S) +7) of the control data.

14.5 ZP.SPCHG1, ZP.SPCHG2, ZP.SPCHG3

Changes the speed of the axis which is in JOG operation during speed control.

Setting data	Applicable device								
	Internal device		File register	Link direct device J□\□		Intelligent function module device U□\G□	Index register Zn	Constant K, H, \$	Other
	Bit	Word		Bit	Word				
(S)	-	○				-	-	-	
(D)	○	○	-			-	-	-	

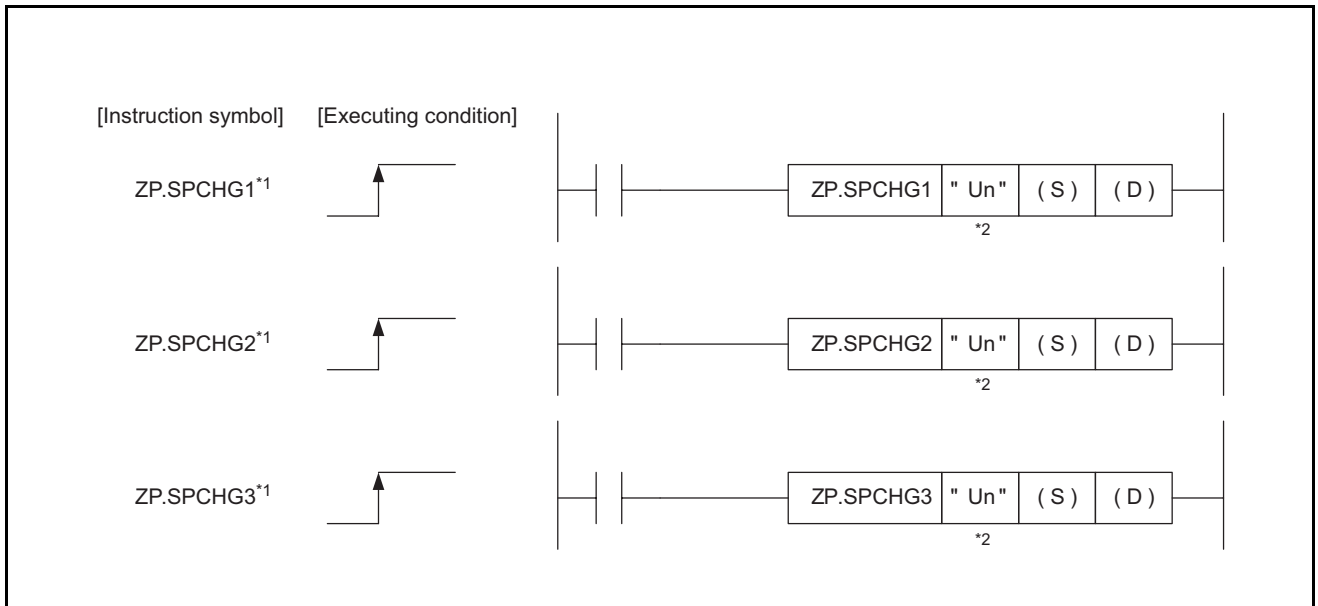

* 1 When describing shared information for ZP.SPCHG1, ZP.SPCHG2, and ZP.SPCHG3, "ZP.SPCHG□" is used.

* 2 If the originating station is a Basic model QCPU (function version B or later), or Universal model QCPU, "" (double quotation) of the first argument can be omitted.

(1) Setting data

Setting data	Setting contents	Set by ^{*3}	Data type
"Un"	Start I/O number of the QD72P3C3 (00 to FD: First two digits when I/O signals are expressed in 3-digit)	User	BIN 16 bit
(S)	Start number of the device in which control data is stored	-	Device
(D)	Start number of the bit device to be turned ON for one scan upon completion of the instruction ((D)+1) also turns ON at error completion.	System	Bit

* 3 Local devices and file registers for each program cannot be used for setting data.

(2) Control data

Device	Item	Setting data	Setting range	Set by ^{*1}
(S) +0	System area	-	-	-
(S) +1	Completion status	Stores the status at completion. •0: Normal completion •Other than 0: Error completion (Error code) ^{*2}	-	System
(S) +2	New speed value	Specifies the speed after performing speed change with the ZP.SPCHG□ instruction.	1 to 100000 (pulse/s)	User
(S) +3				
(S) +4	ACC/DEC time at speed change	Specifies the ACC/DEC time and DEC/STOP time to perform speed change with the ZP.SPCHG□ instruction.	1 to 5000 (ms)	User

* 1 The setting side indicates the following:

- User: Data stored by the user at dedicated instruction execution.
- System: Data stored by the programmable controller CPU at dedicated instruction completion.

* 2 For details of error code at error completion, refer to "Section 15.3".

(3) Function

- (a) Changes the speed of the Axis which is in JOG operation during speed control.
 - ZP.SPCHG1: Axis 1
 - ZP.SPCHG2: Axis 2
 - ZP.SPCHG3: Axis 3
- (b) The speed can be changed by specifying the value at "New speed value" of ((S) +2) and "ACC/DEC time at speed change" of ((S) +3, (S) +4).
- (c) Completion status of the ZP.SPCHG□ instruction can be checked by the completion device ((D) +0) and ((D) +1).
 - 1) Completion device ((D) +0)
Turns ON at END processing in the scan where the ZP.SPCHG□ instruction is completed, and turns OFF at the next END processing.
 - 2) Completion status display device ((D) +1)
Turns ON/OFF according to the status when the ZP.SPCHG□ instruction is completed.
 - Normal completion: Remains OFF.
 - Error completion: Turns ON at END processing in the scan where the ZP.SPCHG□ instruction is completed, and turns OFF at the next END processing. (Same ON/OFF operation as a completion device.)

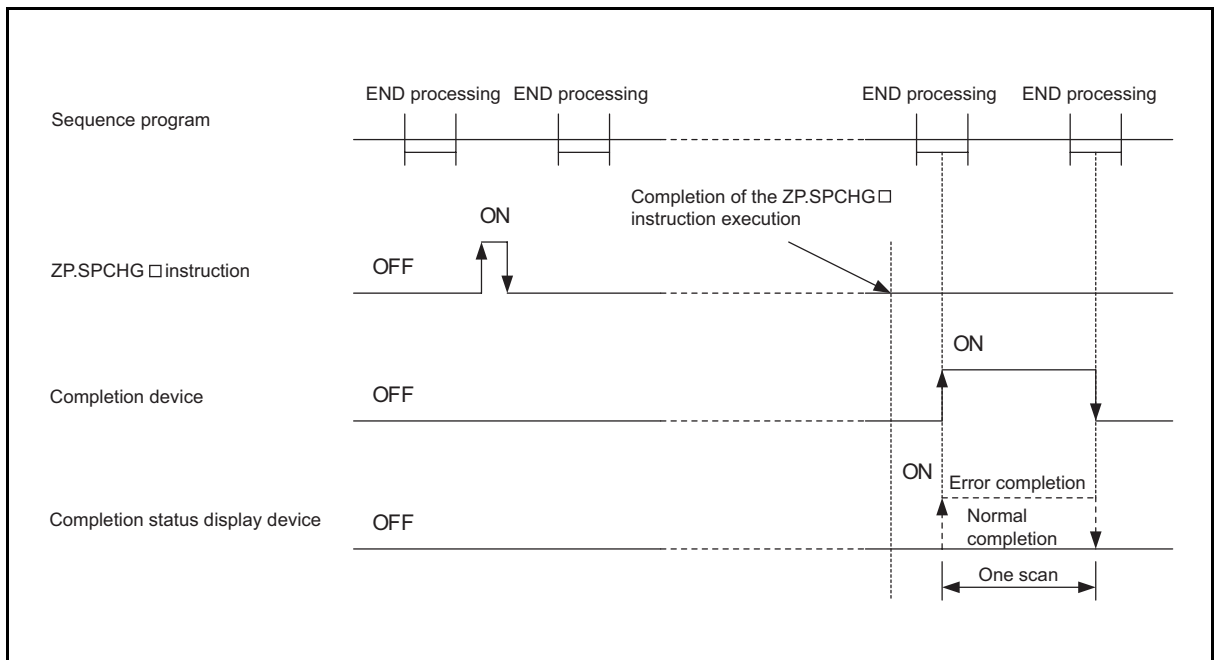

(4) Error

At error completion of the ZP.SPCHG□ instruction, the error completion signal ((D) +1) turns ON and the error code is stored in the completion status ((S) +1).

Refer to the error code list in Section 15.2.1, check the error and take corrective action.

(5) Precautions

- The ZP.SPCHG□ instruction can be executed only at the constant speed section which is in JOG operation, during speed control. In other cases, the speed cannot be changed and the error completion signal ((D) +1) turns ON.
- If the "New speed value" of ((S) +2, (S) +3) exceeds the speed limit value, an operation is performed with the speed limit value. If the command speed is lower than the bias speed, an operation is performed with the bias speed.
- When the remote I/O station (Q corresponding MELSECNET/H network remote I/O module) is used, this dedicated instruction (ZP.SPCHG□) cannot be used.
- In the following cases, "Dedicated instruction error" (error code: 804) occurs when the ZP.SPCHG□ instruction is executed, and the speed cannot be changed.
 - The value other than 1 to 100000 is set for "New speed value" (device: (S) +2, (S) +3) of the control data.
 - The value outside of the range between 1 and 5000 is set for "ACC/DEC time at speed change" (device: (S) +4) of the control data.

CHAPTER 15 TROUBLESHOOTING

This chapter describes the description of errors regarding the QD72P3C3 and troubleshooting for it.

15.1 Troubleshooting Flow

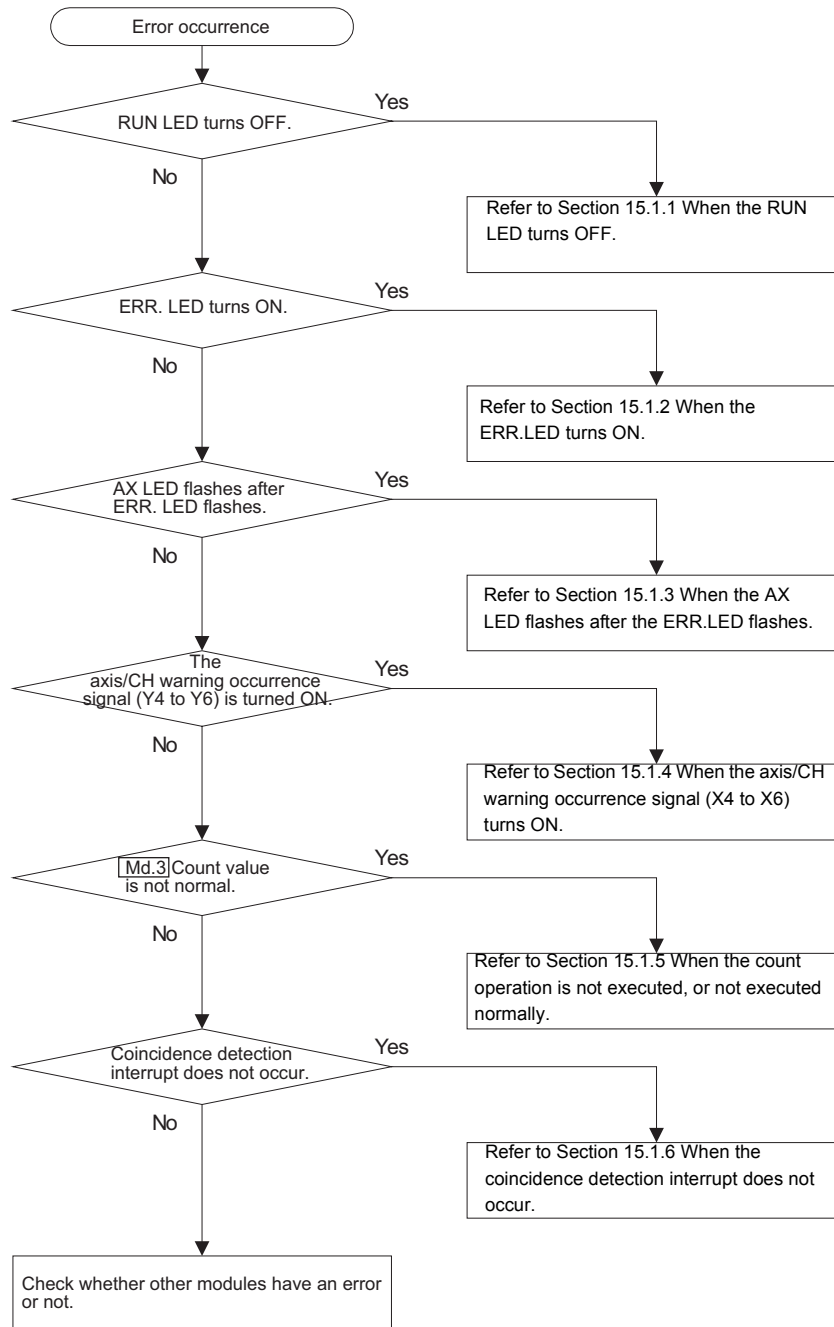

15.1.1 When the RUN LED turns OFF

Check item	Action
Is power supplied?	Check if the service voltage of the power supply module is within the rated range.
Is the capacity of the power supply module sufficient?	Calculate the consumption current of the modules mounted to the base unit such as CPU module, I/O module, and intelligent function module, and check that the power capacity is sufficient.
Is the watchdog timer occurring?	Reset the programmable controller CPU and check that the RUN LED turns ON. If the RUN LED does not turn ON, the module may be at failure. Please consult your local Mitsubishi representative to explain a detailed description of the problem.
Are the modules correctly mounted to the base unit?	Check the module mounting status.

15.1.2 When the ERR.LED turns ON

Check item	Action
Is any error occurring?	Check the error code and take measures described in Section 15.2.1.

15.1.3 When the AX LED flashes after the ERR.LED flashes

Check item	Action
Is any axis error occurring?	Check the error code and take measures described in Section 15.2.1.

15.1.4 When the axis/CH warning occurrence signal (X4 to X6) turns ON

Check item	Action
Is any warning occurring?	Check the warning code and take measures described in Section 15.2.2.

9

POSITIONING CONTROL

10

JOG OPERATION

11

AUXILIARY FUNCTION

12

COUNTER FUNCTION

13

COMMON FUNCTION

14

DEDICATED INSTRUCTIONS

15

TROUBLESHOOTING

APPENDIX

15.1.5 When the count operation is not executed, or not executed normally

Check item		Action
Doesn't the programmable controller CPU indicate an error?		If the LED on the programmable controller CPU indicates an error, correct the error for normal operation with reference to troubleshooting in the manual for the programmable controller CPU used.
Is the external wiring of ϕA and ϕB normal?		Check the external wiring and correct the error.
Measures against noise	Are the shielded twisted pair cables used for pulse input wiring?	Use the shielded twisted pair cables for pulse input wiring.
	Has the measures against noise been taken to the adjacent devices and inside the control panel?	Take noise reduction measures (e.g. attach a CR surge suppressor to the magnet switch).
	Is the distance between the high voltage equipment and the pulse input line kept enough?	Bundle the pulse input lines and put them in a single tube, and keep a distance of 100mm (3.94inch) or more with the power line even inside the control panel.
Do the LEDs of ϕA and ϕB turn ON by applying voltage to pulse input terminals of ϕA and ϕB using such as stabilize power supply?		If the LEDs turn ON, check the external wiring and the wiring of the pulse generator side. If the LEDs do not turn ON, the module may be at failure. Please consult your local Mitsubishi representative to explain a detailed description of the problem.
Are the pulse input method and pulse input mode set with the intelligent function module switch setting the same?		Match the pulse input method with the pulse input mode made on the intelligent function module switch setting.
Is the maximum speed of input pulse within the range of the counting speed setting?		Set the maximum speed of the input pulse within the range of the counting speed.
Does the input pulse waveform match with the performance specifications?		Check the pulse waveform with synchronoscope. When the input pulse does not meet the performance specifications, input the pulse which meets the performance specifications.
Is the count enable command (Y1C to Y1E) ON?		Turn the count enable command (Y1C to Y1E) ON with the sequence program.
Is the overflow occurring?		Execute the preset to clear the overflow.
Is the "Md.3 Count value" read in units of 2 words (32bits) in the sequence program?		Read with a batch of 2 words.

15.1.6 When the coincidence detection interrupt does not occur

Check item	Action
Is the Q00J/Q00/Q01CPU (function version A) used as the programmable controller CPU?	Change the CPU module to the one which supports the intelligent function module event interrupt. (refer to Section 2.3)
Is the module configured as a network module (remote I/O station)?	Configure the module as the programmable controller CPU. (refer to Section 2.3)
Is the setting made on [Interrupt pointer setting] of [Intelligent function module setting] in [PLC parameter] correct?	Check the intelligent function module interrupt pointer setting.
Is the way to use the program execution control instruction such as the IMASK correct?	Check the sequence program.
Does the count value coincidence (X15, X19, X1D) remain ON?	Reset (OFF) the count value coincidence (X15, X19, X1D) by the coincidence signal reset command (Y14 to Y16).

15.2 Error and Warning Descriptions

(1) Errors

■ Types of errors

Errors detected by the QD72P3C3 include errors out of the parameter settings, and errors at the operation start or during operation.

(a) Parameter setting range errors

The parameters are checked at the rising edge (OFF→ON) of the programmable controller CPU READY signal (Y0). An error occurs when the parameter setting details are incorrect.

When this kind of error occurs, the module READY signal (X0) does not turn ON. To cancel the error, set the correct value in the parameter which the error occurred, and then turn ON the programmable controller CPU READY signal (Y0).

(b) Errors at the operation start or during operation

These are errors that occur at the operation start or during operation when the OPR control, positioning control, or JOG operation is used.

If any error occurs on any axis at a start, the axis does not start and "[Md.4] Axis operation status" changes to "Error".

If any error occurs on any axis during operation, the axis decelerates to stop and "[Md.4] Axis operation status" changes to "Error".

■ Error storage

When an error occurs, the axis/CH error occurrence signal (X1 to X3) turns ON and the error code corresponding to the error description is stored in "[Md.5] Axis/CH error code".

Axis/CH number	Axis/CH error occurrence signal (X1 to X3)	" [Md.5] Axis/CH error code" buffer memory address
1	X1	77
2	X2	177
3	X3	277

* For setting contents, refer to "Section 4.5 Monitor Data List".

If another error occurs during axis/CH error occurrence, the latest error code is ignored. However, if any of the system-affecting errors (error codes: 800 to 830) occurs, the old error code is overwritten by the newest error code.

(The error codes 800 to 830 are stored into "[Md.5] Axis/CH error code" for all axes.)

(2) Warnings

■ Types of warnings

These are warnings that occur during operation when the OPR control, positioning control, or JOG operation is used.

Even if a warning occurs, the operation continues. In addition, even if a warning occurs, "[Md.4] Axis operation status" does not change.

■ Warning storage

When a warning occurs, the axis/CH warning occurrence signal (X4 to X6) turns ON and the warning code corresponding to the warning description is stored in

"[Md.6] Axis/CH warning code".

Axis/CH number	Axis/CH warning occurrence signal (X4 to X6)	" [Md.6] Axis/CH warning code" Buffer memory address
1	X4	78
2	X5	178
3	X6	278

* For setting contents, refer to "Section 4.5 Monitor Data List".

For the axis warning code, the latest warning code is always stored.

(3) Resetting errors and warnings

By turning ON the axis/CH error reset (Y1 to Y3), the following is processed and then the error/warning status is cleared.

- The axis/CH error occurrence signals (X1 to X3) are OFF. (the axis/CH error reset signals (Y1 to Y3) for all axes are turned ON.)
- The axis/CH warning occurrence signals (X4 to X6) are turned OFF. (the axis/CH error reset signals (Y1 to Y3) for all axes are turned ON.)
- "[Md.4] Axis operation status" changes from "Error" to "Standby".
- "[Md.5] Axis/CH error code" is cleared to 0.
- "[Md.6] Axis/CH warning code" is cleared to 0.

(4) Checking error and warning description

The error and warning description can be checked with "[Md.5] Axis/CH error code" and "[Md.6] Axis/CH warning code". To check them, GX Developer or GX Configurator-PT is needed. For details, refer to "Section 15.4 Checking Error Description Using System Monitor of GX Developer" or "CHAPTER 6 UTILITY PACKAGE (GX Configurator-PT)". (For details of error code and warning code, refer to .Section 15.2 and Section 15.3.)

15.2.1 Error code list

The following table shows the error descriptions and measures to be taken when an error occurs.

Error code (decimal)	Error name	Description	Operation at error
0	Normal status	-	-
100	Fault	Hardware is a failure.	The system stops.
102	Stop signal ON at start	A start requested is executed when the axis stop signal (Y4 to Y6) is ON.	The axis does not start.
103	Hardware stroke limit +	Hardware stroke limit (upper limit signal (FLS)) turned OFF.	At start: The axis does not start.
104	Hardware stroke limit -	Hardware stroke limit (lower limit signal (RLS)) turned OFF.	During operation: The axis decelerates to stop when the limit signal turns OFF during positioning control, speed control and JOG operation.
105	Programmable controller CPU READY OFF during operation	The programmable controller CPU READY signal (Y0) is turned OFF during operation.	The axis decelerates to stop.
110	Programmable controller CPU READY OFF during writing	The programmable controller CPU READY signal (Y0) is turned OFF immediately after turned ON.	-
202	Zero signal ON	Stopper 3 (the setting in "[Pr.10] OPR method"): A zero signal has already been input at the start of machine OPR control. Near-point dog method (the setting in "[Pr.10] OPR method": During control operation, a zero signal turned ON when the near-point dog signal turned OFF.	Stopper 3: The machine OPR control is not performed. Near-point dog method: The control operation is immediately stopped.
203	Machine OPR not performed	Fast OPR control was started without performing machine OPR control.	Fast OPR control is not performed.

Error code (decimal)	Related buffer memory address			Setting range	Remedy
	Axis 1/ CH 1	Axis 2/ CH 2	Axis 3/ CH 3		
0	-	-	-	-	-
100	-	-	-	-	Turn OFF and then ON the power, or reset the CPU. If the error code is still stored after taking measures, QD72P3C3 may be at fault. Please consult your local Mitsubishi representative to explain a detailed description of the problem.
102	-	-	-	-	Check whether the axis stop signal (Y4 to Y6) is ON or OFF, and turn OFF the axis stop signal (Y4 to Y6) that is ON.
103	-	-	-	-	After resetting the error, move the upper limit signal (FLS) to where the signal does not turn OFF.
104	-	-	-	-	After resetting the error, move the lower limit signal (RLS) to where the signal does not turn OFF.
105	-	-	-	-	Review the sequence program that turns ON/OFF the programmable controller CPU READY signal (Y0).
110	-	-	-	-	
202	-	-	-	-	Stopper 3: Turn OFF the zero signal and start the machine OPR control. Near-point dog method: Adjust the near-point dog signal OFF position as close as possible to the center of the zero signal HIGH level.
203	56	156	256	[Cd.5] Start method 0: Positioning control 9000: Machine OPR control 9001: Fast OPR control	Before starting fast OPR control, execute machine OPR control.

Error code (decimal)	Error name	Description	Operation at error
501	Out of start method setting range	The setting value of " [Cd.5] Start method" is other than 0, 9000, or 9001.	The axis does not start.
504	Out of operation pattern setting range	The setting value of " [Da.1] Operation pattern" is out of the setting range.	
506	Out of control method setting range	The setting value of " [Da.2] Control method" is out of the setting range.	
507	Out of ACC/DEC time setting range	Any of the " [Pr.15] ACC/DEC time at OPR", " [JOG.2] JOG ACC/DEC time", " [Da.3] ACC/DEC time", and " [Cd.2] ACC/DEC time at speed change" setting values is out of the setting range.	
509	Out of positioning address/movement amount setting range	The setting value of " [Da.5] Positioning address/movement amount" is out of the setting range.	
516	Software stroke limit +	Positioning control was performed in a position in excess of " [Pr.1] Software stroke limit upper limit value". " [Md.1] Current feed value", " [Da.5] Positioning address/movement value" (New current value) has exceeded " [Pr.1] Software stroke limit upper limit value".	At start: The axis does not start. At current value change: Current value change is not performed. During speed control, or JOG operation, the axis decelerates to stop as soon as the " [Md.1] Current feed value" exceeds the software stroke limit range. During positioning control, the axis decelerates to stop as soon as the " [Md.1] Current feed value" or " [Da.5] Positioning address/movement amount" exceeds the software stroke limit range.
517	Software stroke limit -	Positioning control was carried out in a position in excess of " [Pr.2] Software stroke limit lower limit value". " [Md.1] Current feed value", " [Da.5] Positioning address/movement value"(New current value) has exceeded " [Pr.2] Software stroke limit lower limit value".	
518	Out of current feed value range	The " [Md.1] Current feed value" exceeds the " [Pr.17] Positioning range upper limit value".	The axis does not start.

Error code (decimal)	Related buffer memory address			Setting range	Remedy
	Axis/CH 1	Axis/CH 2	Axis/CH 3		
501	56	156	256	<p>[Cd.5] Start method</p> <p>0: Positioning control</p> <p>9000: Machine OPR control</p> <p>9001: Fast OPR control</p>	Set the "[Cd.5] Start method" within the setting range.
504	<p>Refer to "Section 4.2 Parameter List".</p> <p>Refer to "Section 4.3 JOG Data List".</p> <p>Refer to "Section 4.4 Positioning Data List".</p> <p>Refer to "Section 4.6 Control Data List".</p>				Set the "[Da.1] Operation pattern" within the setting range.
506					Set the "[Da.2] Start method" within the setting range.
507					Set "[Pr.15] ACC/DEC time at OPR", "[JOG.2] JOG ACC/DEC time", "[Da.3] ACC/DEC time", and "[Cd.2] ACC/DEC time at speed change" within the setting range.
509					Set "[Da.5] Positioning address/movement amount" within the setting range.
516	0 1	100 101	200 201	<p>[Pr.1] Software stroke limit upper limit value</p> <p>-1073741824 to 1073741823 (pulse)</p>	<p>At start: Set the "[Md.1] Current feed value" within the software stroke limit range by JOG operation.</p> <p>At current value change: Change the new current value within the software stroke limit.</p>
517	2 3	102 103	202 203	<p>[Pr.2] Software stroke limit lower limit value</p> <p>-1073741824 to 1073741823 (pulse)</p>	During operation: Correct the "[Da.5] Positioning address/movement amount".
518	32 33	132 133	232 233	<p>[Pr.17] Positioning range upper limit value</p> <p>0 to 1073741823 (pulse)</p>	<p>•Set the "[Md.1] Current feed value" within the range of the "[Pr.17] Positioning range upper limit value" in the current value change.</p> <p>•Execute OPR.</p>

Error code (decimal)	Error name	Description	Operation at error
800	Hold error	The setting for the QD72P3C3 is "Hold" in the "Error time output mode" parameter of the CPU module.	The axis does not start.
804	Dedicated instruction error	<ul style="list-style-type: none"> •ZP.PSTRT□ instruction was executed when the start method was other than 0, 9000, or 9001. •ZP.DSTRT□ instruction was executed when the control method was other than 1 to 5. •ZP.DSTRT□ instruction was executed when the ACC/DEC time was other than 1 to 5000. •ZP.SPCHG□ instruction was executed when the ACC/DEC time was other than 1 to 5000. 	<p>At start: The axis does not start.</p> <p>During operation: The axis decelerates to stop.</p>
820	Programmable controller CPU error	I/O reset occurred.	<p>At start: The axis does not start.</p> <p>During operation: The axis decelerates to stop.</p>
830	Watchdog timer error of programmable controller CPU	Watchdog timer error of programmable controller CPU occurred.	<p>At start: The axis does not start.</p> <p>During operation: The axis decelerates to stop.</p>
901	Software stroke limit upper/lower limit value error	(Upper limit value) \leq (Lower limit value) is satisfied in the software stroke limit upper/lower limit values.	
904	Out of current feed value during speed control setting range	The setting value of the " Pr.3 Current feed value during speed control" is out of the setting range.	The module READY signal (X0) does not turn ON.
905	Out of speed limit value range	The setting value of the " Pr.4 Speed limit value" is out of the setting range.	
906	Out of bias speed at start setting range	<ul style="list-style-type: none"> •The setting value of " Pr.5 Bias speed at start" is out of the setting range. •The setting value of the " Pr.5 Bias speed at start" exceeds the " Pr.4 Speed limit value". •The setting value of the " Pr.5 Bias speed at start" is less than pulse unit. 	

Error code (decimal)	Related buffer memory address			Setting range	Remedy
	Axis/ CH 1	Axis/ CH 2	Axis/ CH 3		
800	-	-	-	-	Change the setting of the "Error time output mode" parameter of the CPU module to "Clear". (Refer to QCPU User's manual.)
804				(ZP.PSTRT□ start method) 0, 9000, 9001 (ZP.DSTRT□ control method) 1 to 5 (ZP.DSTRT□ ACC/DEC time) 1 to 5000 (ZP.SPCHG□ ACC/DEC time) 1 to 5000	<ul style="list-style-type: none"> •When executing the ZP.PSTRT□ instruction, set the start method within the range. Refer to Section 14.3.) •When executing the ZP.DSTRT□ instruction, set the ACC/DEC time within the range. (Refer to Section 14.4.) •When executing the ZP.SPCHG□ instruction, set the ACC/DEC time within the range. Refer to Section 14.5.)
820	-	-	-	-	Turn OFF and then ON the power, or reset the programmable controller CPU.
830	-	-	-	-	(Refer to QCPU User's manual)
901	0	100	200	□Pr.1 Software stroke limit upper limit value	Set the values to satisfy (Upper limit value) > (Lower limit value). (Refer to Section 11.4.)
	1	101	201	-1073741824 to 1073741823 (pulse)	
904	2	102	202	□Pr.2 Software stroke limit lower limit value	Set the value within the setting range and turn OFF and then ON the programmable controller CPU READY signal (Y0).
	3	103	203	-1073741824 to 1073741823 (pulse)	
905	5	105	205	□Pr.3 Current feed value during speed control 0: No update 1: Update	
906	6	106	206	□Pr.4 Speed limit value	Set the value within the setting range and less than the "□Pr.4 Speed limit value". Then turn OFF and then ON the programmable controller CPU READY signal (Y0).
	7	107	207	1 to 100000 (pulse/s)	
906	8	108	208	□Pr.5 Bias speed at start	
	9	109	209	1 to 100000 (pulse/s)	

Error code (decimal)	Error name	Description	Operation at error
907	Out of deviation counter clear signal output time setting range	The setting value of the " [Pr.7] Deviation counter clear signal output time" is out of the setting range.	The module READY signal (X0) does not turn ON.
910	Out of OPR method setting range	The setting value of the " [Pr.10] OPR method" is out of the setting range.	
911	Out of OPR direction setting range	The setting value of the " [Pr.11] OPR direction" is out of the setting range.	
912	Out of OP address setting range	The setting value of the " [Pr.12] OP address" is out of the setting range. The setting of the " [Pr.12] OP address" is out of the positioning range when using the ring counter. When the " [Pr.19] Count value selection at OPR" is set to "1: OP address set to count value" for the ring counter, the setting of the " [Pr.12] OP address" is out of the count range.	
913	Out of OPR speed setting range	The setting value of the " [Pr.13] OPR speed" is out of the setting range. The setting value of the " [Pr.13] OPR speed" is lower than the " [Pr.14] Creep speed". The setting value of the " [Pr.13] OPR speed" exceeds the " [Pr.4] Speed limit value".	

Error code (decimal)	Related buffer memory address			Setting range	Remedy
	Axis 1/ CH 1	Axis 2/ CH 2	Axis 3/ CH 3		
907	10	110	210	[Pr.7] Deviation counter clear signal output time 0: 1ms 1: 2ms 2: 10ms 3: 20ms	Set the value within the setting range and turn OFF and then ON the programmable controller CPU READY signal (Y0).
910	20	120	220	[Pr.10] OPR method 0: OPR method 1) Near-point dog method 1: OPR method 2) Stopper 3	
911	21	121	221	[Pr.11] OPR direction 0: Forward direction 1: Reverse direction	
912	22 23	122 123	222 223	[Pr.12] OP address -1073741824 to 1073741823 (pulse)	
913	24 25	124 125	224 225	[Pr.13] OPR speed 1 to 100000 (pulse/s)	

Error code (decimal)	Error name	Description	Operation at error
914	Out of creep speed setting range	<p>The setting value of the " [Pr.14] Creep speed" is out of the setting range.</p> <p>The setting value of the " [Pr.14] Creep speed" is higher than the " [Pr.13] OPR speed".</p> <p>The setting value of the " [Pr.14] Creep speed" is less than pulse unit.</p>	The module READY signal (X0) does not turn ON.
915	Out of ACC/DEC time at OPR setting range	The setting value of the " [Pr.15] ACC/DEC time at OPR" is out of the setting range.	
923	Out of current feed value, count value simultaneous change function selection setting range	The setting value of the " [Pr.9] Current feed value, count value simultaneous change selection" is out of the setting range.	
924	Out of coincidence detection setting range	<p>The setting value of the " [Pr.18] Coincidence detection setting" is out of the setting range.</p> <p>Ring counter is set for the counter format of the intelligent function module switch setting, which is set by GX Developer.</p>	
925	Coincidence detection function/ring counter function setting error	When ring counter is set for the counter format, the " [Pr.18] Coincidence detection setting" is set to "1: Coincidence detection requested".	

Error code (decimal)	Related buffer memory address			Setting range	Remedy
	Axis/CH 1	Axis/CH 2	Axis/CH 3		
914	26 27	126 127	226 227	[Pr.14] Creep speed 1 to 100000 (pulse/s)	Set the value within the setting range and lower than the "[Pr.13] OPR speed", and turn OFF and then ON the programmable controller CPU READY signal (Y0).
915	28 29	128 129	228 229	[Pr.15] ACC/DEC time at OPR 1 to 5000 (ms)	
923	13	113	213	[Pr.9] Current feed value, count value simultaneous change function selection 0: Values not changed simultaneously 1: Count value changed together at currnt value change 2: Current feed value changed together at preset 3: Values changed both at current value change and at preset	Set the value within the setting range and turn OFF and then ON the programmable controller CPU READY signal (Y0).
924	34	134	234	[Pr.18] Coincidence detection setting 0: Coincidence detection not request 1: Coincidence detection requested	
925					

Error code (decimal)	Error name	Description	Operation at error
926	Out of count value selection at OPR setting range	The setting value of the " [Pr.19] Count value selection at OPR" is out of the setting range.	The module READY signal (X0) does not turn ON.
927	Out of ring counter upper limit value setting range	The setting value of the " [Pr.16] Ring counter upper limit value" is out of the setting range.	
928	Out of software stroke limit upper limit value setting range	The setting value of the " [Pr.1] Software stroke limit upper limit value" is out of the setting range.	
929	Out of software stroke limit lower limit value setting range	The setting value of the " [Pr.2] Software stroke limit lower limit value" is out of the setting range.	
930	Out of positioning range upper limit value setting range	The setting value of the " [Pr.17] Positioning range upper limit value" is out of the setting range.	

Error code (decimal)	Related buffer memory address			Setting range	Remedy
	Axis 1/ CH 1	Axis 2/ CH 2	Axis 3/ CH 3		
926	35	135	235	[Pr.19] Count value selection at OPR 0: OP address not set to count value 1: OP address set to count value	Set the value within the setting range and turn OFF and then ON the programmable controller CPU READY signal (Y0).
927	30 31	130 131	230 231	[Pr.16] Ring counter upper limit value 0 to 1073741823 (pulse)	
928	0 1	100 101	200 201	[Pr.1] Software stroke limit upper limit value -1073741824 to 1073741823 (pulse)	
929	2 3	102 103	202 203	[Pr.2] Software stroke limit lower limit value -1073741824 to 1073741823 (pulse)	
930	32 33	132 133	232 233	[Pr.17] Positioning range upper limit value 0 to 1073741823 (pulse)	

15.2.2 List of warnings

The following table shows the warning descriptions and measures to be taken when a warning occurs.

Warning code (decimal)	Warning name	Description	Operation at warning
000	(Normal)	-	-
10	Start during operation	The start is requested during the axis is BUSY.	The operation is continued.
20	Out of speed range	" [Da.4] Command speed", and " [Cd.1] New speed value" are less than the " [Pr.5] Bias speed at start", or exceed the " [Pr.4] Speed limit value".	Control the speed with the " [Pr.5] Bias speed at start" or " [Pr.4] Speed limit value".
22	Speed change disabled	Speed change was requested for other than speed control and JOG operation.	The operation is continued.
23	Preset disabled	Preset command (Y18 to Y1A) is executed during operation when the " [Pr.9] current feed value, count value simultaneous change function" is set to "2: Current feed value changed together at preset" or "3: Values changed both at current value change and at preset"	Preset is not executed, and operation or count operation is continued.
24	Out of preset value setting range	<ul style="list-style-type: none"> The setting value of the " [Cd.6] Preset value setting" is out of the setting range. When the " [Pr.9] current feed value, count value simultaneous change function" is set to "2: Current feed value changed together at preset" or "3: Values changed both at current value change and at preset", the setting value of the " [Cd.6] Preset setting value" exceeds the "Software stroke limit upper/lower limit value" . 	
25	Coincidence detection disabled	The setting value of the " [Cd.7] Coincidence detection point setting" is out of the setting range.	Coincidence detection is not executed, and operation or count operation is continued.
26	Out of ACC/DEC time setting valid range	Any of the " [Pr.15] ACC/DEC time at OPR", " [JOG.2] JOG ACC/DEC time", " [Da.3] ACC/DEC time", and " [Cd.2] ACC/DEC time at speed change" setting values is out of the setting valid range.	The operation is carried out at the maximum value or the minimum value of the setting valid range.
27	Overflow	Count value exceeded -1073741824 (lower limit value), or 1073741824 (upper limit value) when the linear counter is selected.	Count operation is stopped. (Positioning operation is continued.)
31	Out of count value range	The " [Md.3] Count value" exceeds the " [Pr.16] Ring counter upper limit value".	Count is executed with an invalid value.

Warning code (decimal)	Related buffer			Setting range	Remedy
	Axis/CH 1	Axis/CH 2	Axis/CH 3		
000	-	-	-	-	-
10	-	-	-	-	Normalize the start request ON timing.
20	6	106	206	$\boxed{\text{Pr.4}}$ Speed limit value 1 to 100000 (pulse/s)	Set the " $\boxed{\text{Cd.1}}$ New speed value" to be higher than the " $\boxed{\text{Pr.5}}$ Bias speed at start" and lower than the " $\boxed{\text{Pr.4}}$ Speed limit value".
	7	107	207		
	8	108	208	$\boxed{\text{Pr.5}}$ Bias speed at start 1 to 5000 (pulse/s)	
	9	109	209		
22	55	155	255	$\boxed{\text{Cd.3}}$ Speed change request 1: Speed change requested	Do not change the speed during position control and OPR control.
23	60	160	260	$\boxed{\text{Cd.3}}$ Preset value setting -1073741824 to 1073741823	Do not execute the preset command (Y18 to Y1A) during operation.
	61	161	261		
24	60	160	260	$\boxed{\text{Cd.3}}$ Preset value setting •At linear count: -1073741824 to 1073741823 •At ring count: 0 to 1073741823	Set the value within the setting range, and turn OFF and then ON the preset command (Y18 to Y1A).
	61	161	261		
25	62	162	262	$\boxed{\text{Cd.7}}$ Coincidence detection point setting -1073741824 to 1073741823	Set the value within the setting range, and turn OFF and then ON the count enable signal.
26				Refer to "Section 4.2 Parameter List". Refer to "Section 4.3 JOG Data List". Refer to "Section 4.4 Positioning Data List". Refer to "Section 4.6 Control Data List".	Set " $\boxed{\text{Pr.15}}$ ACC/DEC time at OPR", " $\boxed{\text{JOG.2}}$ JOG ACC/DEC time", " $\boxed{\text{Da.3}}$ ACC/DEC time", and " $\boxed{\text{Cd.2}}$ ACC/DEC time at speed change" within the setting valid range.
27	-	-	-	-	Execute preset.
31	30	130	230	$\boxed{\text{Pr.16}}$ Ring counter upper limit value 0 to 1073741823 (pulse)	Set the " $\boxed{\text{Md.3}}$ Count value" within the range of the " $\boxed{\text{Pr.16}}$ ring counter upper limit value" by the preset

15.3 Checking Errors with the LED Display Function

The status of the QD72P3C3 and control status of each axis/CH can be checked by the LEDs located on the front of the QD72P3C3.

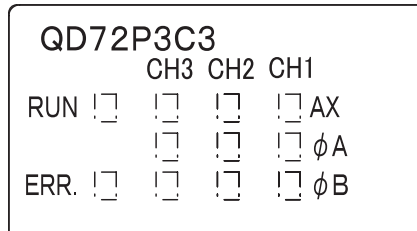

Each axis can be monitored by the status of the LEDs.
The operation and displays are as shown below.

Display contents	Operation status	Description	Display contents	Operation status	Description
RUN □ □ □ □ AX □ □ □ □ φA ERR. □ □ □ □ φB	•RUN LED is OFF. (The status of ERR. LED, AX1 to AX3 are undefined.)	Hardware: Failure Module: Error	RUN ■ □ □ ■ AX □ □ □ □ φA ERR. □ □ □ □ φB	•AX_CH1 LED is ON. (Same for other axes.)	Axis: In operation
RUN ■ □ □ □ AX □ □ □ □ φA ERR. □ □ □ □ φB	•RUN LED is ON. •ERR. LED is OFF.	Module: Normal	RUN ■ □ □ ◆ AX □ □ □ □ φA ERR. ◆ □ □ □ φB	•AX_CH1 LED is flashing. (Same for other axes.) •ERR. LED is flashing.	Axis/CH: Error
RUN ■ □ □ □ AX □ □ □ □ φA ERR. ■ □ □ □ φB	•RUN LED is ON. ERR. LED is ON. •ERR. LED is ON.	System: Error	RUN ■ □ □ □ AX □ □ □ ■ φA ERR. □ □ □ □ φB	•φA_CH1 LED is ON. (Same for other CHs.)	Phase A voltage: Applying
RUN ■ □ □ □ AX □ □ □ □ φA ERR. □ □ □ □ φB	•AX_CH1 to AX_CH3 LEDs are OFF.	Axes: Stopped Axes: Standby	RUN ■ □ □ □ AX □ □ □ □ φA ERR. □ □ □ ■ φB	•φB_CH1 LED is ON. (Same for other CHs.)	Phase B voltage applying

15.4 Checking Error Description Using System Monitor of GX Developer

Error codes for axis errors can be checked by selecting [Module's Detailed Information...] on the [System Monitor] screen of GX Developer.

(1) GX Developer operation

Select [Diagnostics...] → [System Monitor...] → "QD72P3C3" →

Module's Detailed Information .

(2) Checking error codes

The error code stored in the "Md.5 Axis error code" is displayed in the "Present Error" field. (One of the axes from 1 to 3)

(By clicking the Error log button, the error code of the error that has occurred for each axis is displayed in order of axis 1 to 3. Note that this display does not give a history.)

Module's Detailed Information

Module
 Module Name QD72P3C3 Product information 09041000000000 - B
 I/O Address 0
 Implementation Position Main Base 0Slot

Module Information
 Module access Possible I/O Clear / Hold Settings
 Status of External Power Supply Noise Filter Setting
 Fuse Status Input Type
 Status of I/O Address Verify Agree Remote password setting status

Error Display

No.	Error Code
1	1507

Present Error 507

Display format
 HEX DEC

Error History

The display sequence of the error history is from the oldest error. The latest error is displayed in the line as under.

Error contents - Disposal
 Contents:
 Disposal:

H/W Information... Start monitor Stop monitor Close

[Error display descriptions]

 Error code of Axis n
 Axis n (1 ≤ n ≤ 3)

[Present Error]
 The number means the error code 507
 "Out of ACC/DEC time setting range".

[Display format]
 Select "DEC".
 (The error codes indicated in "Section 15.2.1 Error code list" are in decimal.)

APPENDICES

Appendix 1 External Dimensions

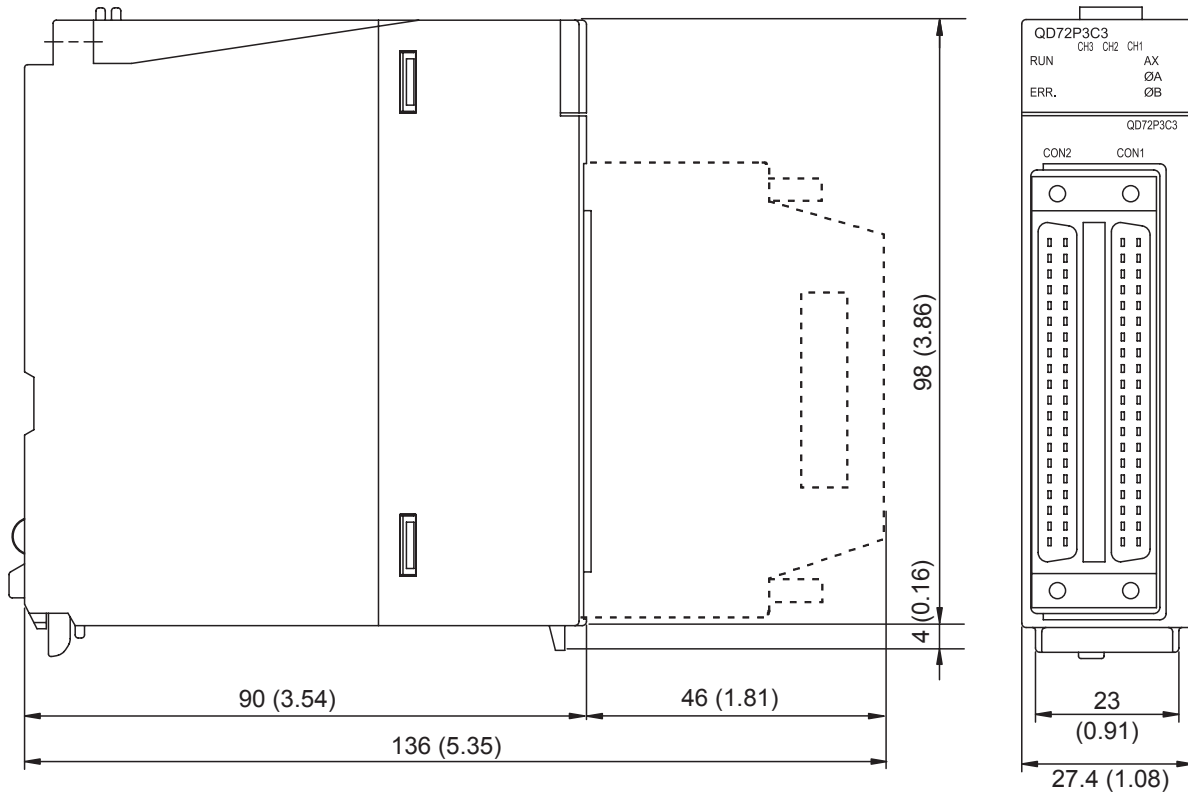

Unit: mm (inch)

Appendix 2 Operation Timing and Processing Time in Each Control

(1) Operation timing and processing time of machine OPR control

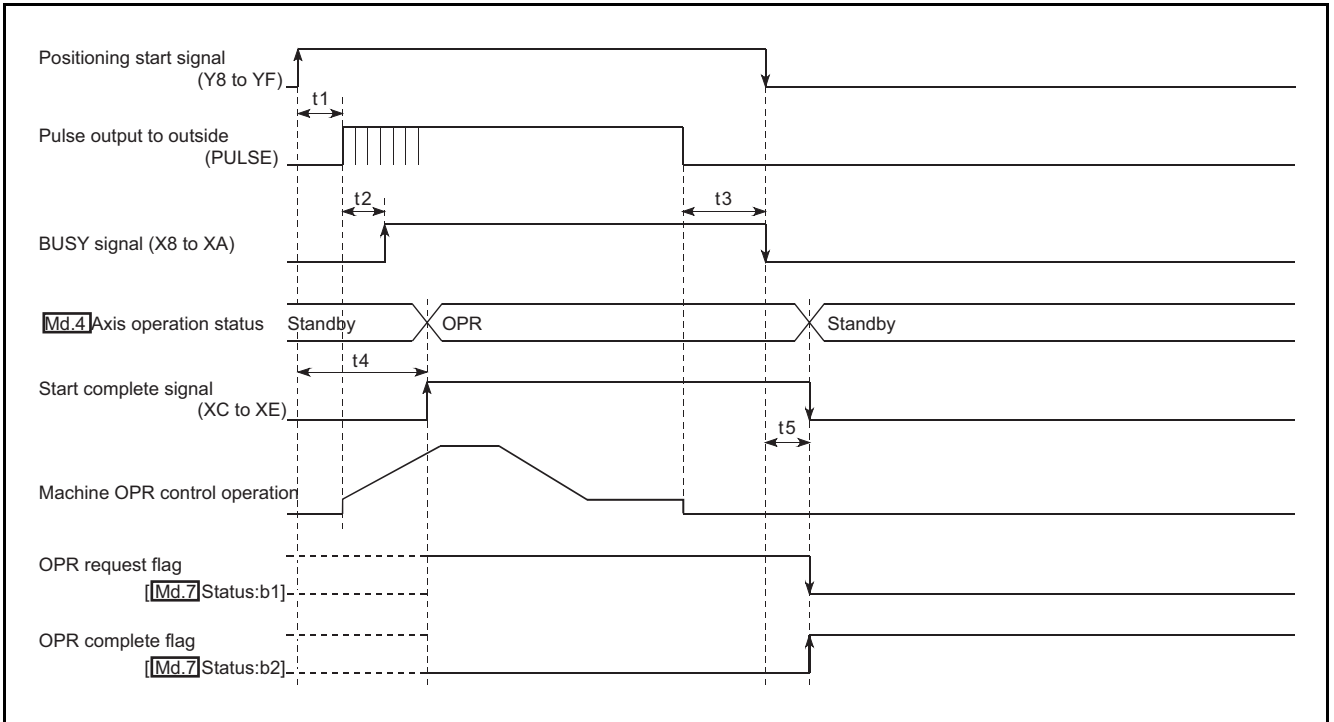

t1	t2	t3	t4	t5
1ms	0.2ms	0 to 2.5ms	0 to 2.5ms	0 to 2.5ms

A delay may occur in the t1 depending on the operating conditions of the other axes.

(2) Operation timing and processing time of fast OPR control

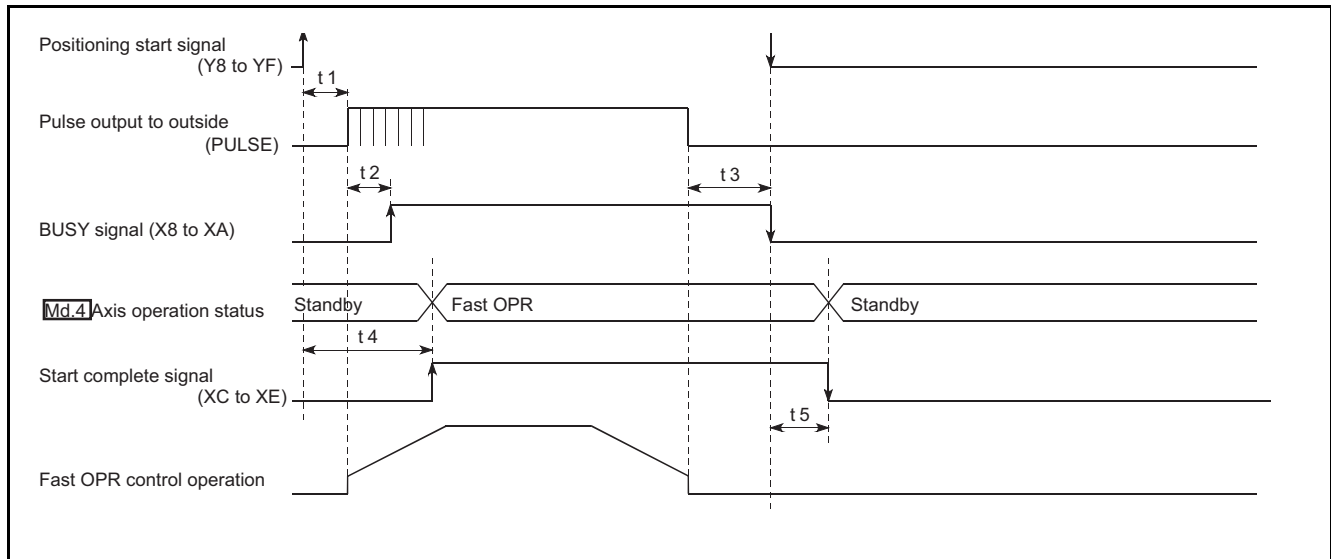

t1	t2	t3	t4	t5
1ms	0.2ms	0 to 2.5ms	0 to 2.5ms	0 to 2.5ms

A delay may occur in the t_1 depending on the operating conditions of the other axes.

(3) Operation timing and processing time of position control

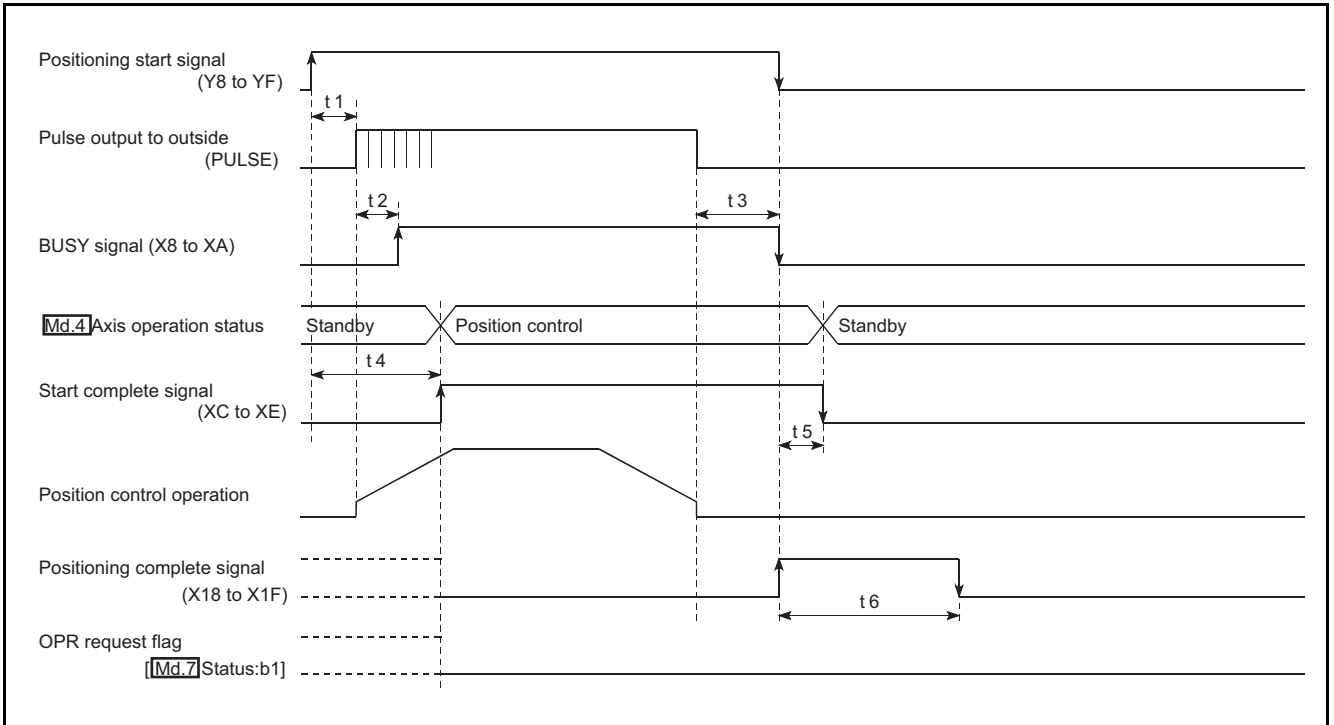

t1*	t2	t3	t4	t5	t6
1ms	0.2ms	0 to 2.5ms	0 to 2.5ms	0 to 2.5ms	As set in parameter

* t1 at multiple axes concurrent start

Number of started axes	t1
3-axes concurrent start	1ms

A delay may occur in the t1 depending on the operating conditions of the other axes.

(4) Operation timing and processing time of speed control

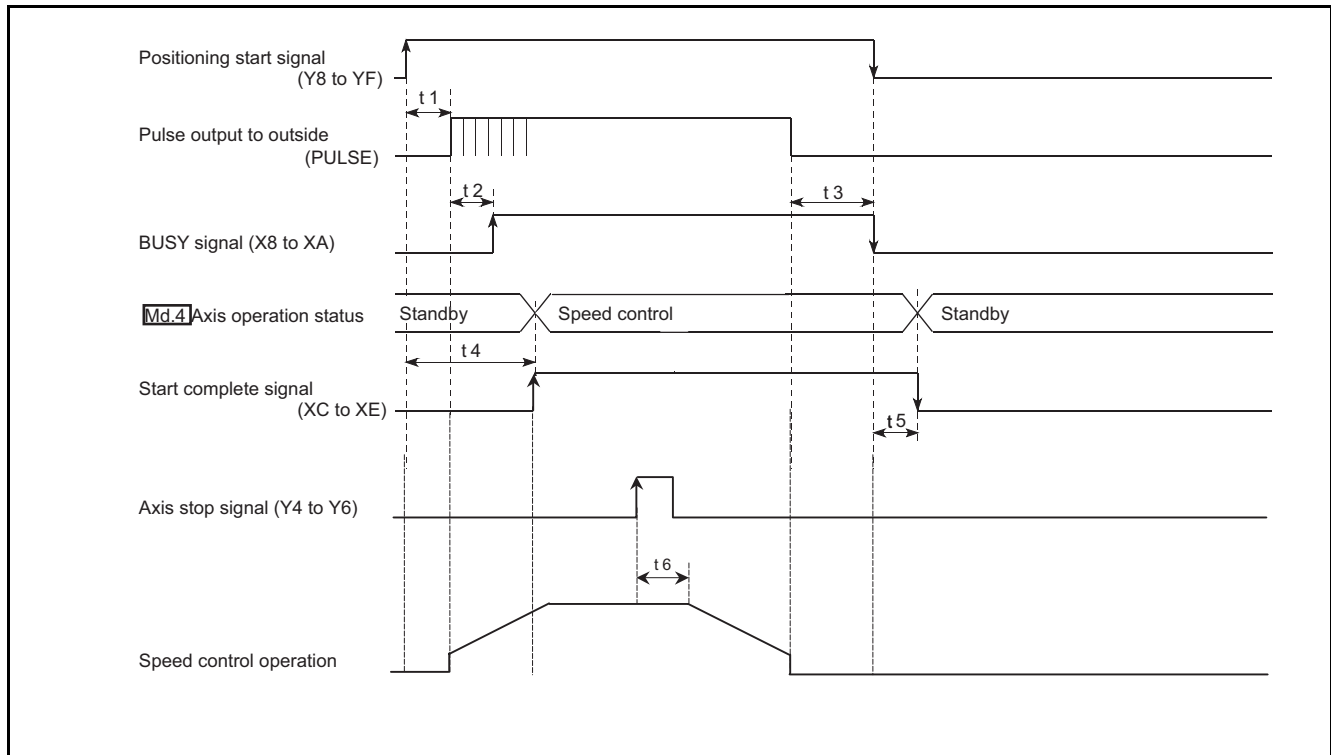

t1	t2	t3	t4	t5	t6
1ms	0.2ms	0 to 2.5ms	0 to 2.5ms	0 to 2.5ms	0 to 2.5ms

A delay may occur in the t1 depending on the operating conditions of the other axes.

(5) Operation timing and processing time of JOG operation

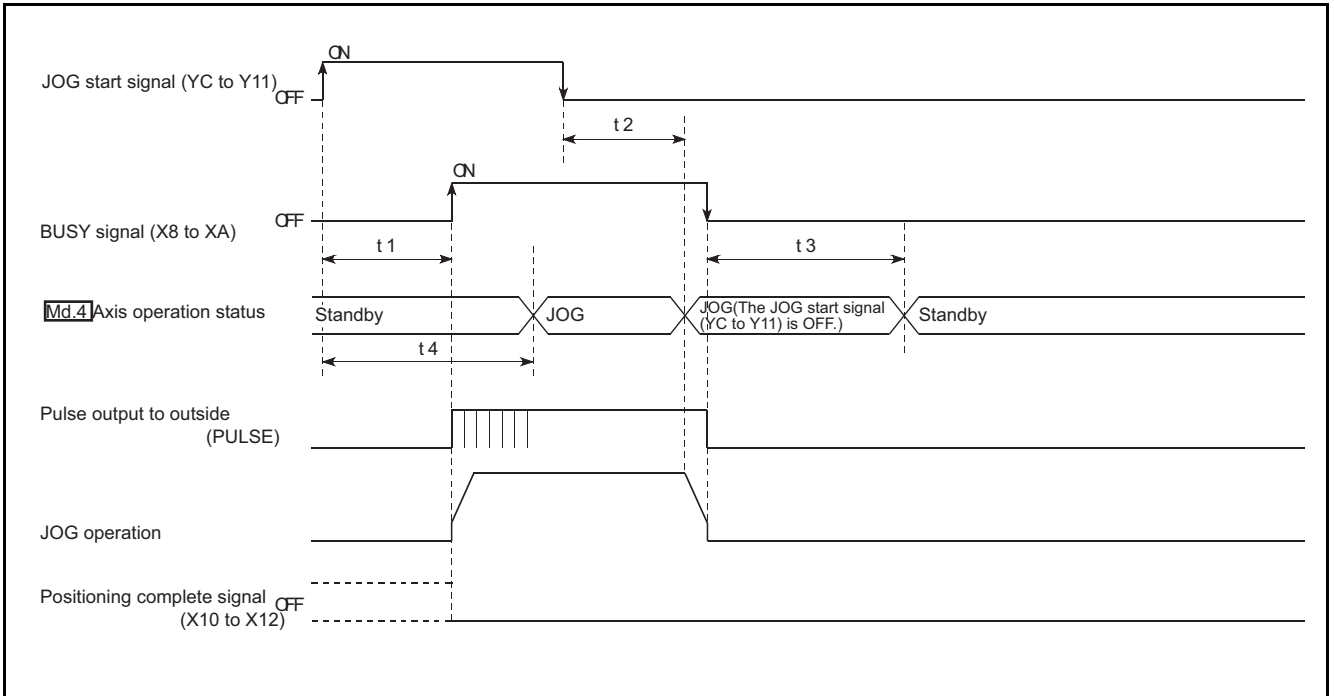

t1	t2	t3	t4
2.5ms	0 to 2.5ms	0 to 2.5ms	0 to 2.5ms

A delay may occur in the t1 depending on the operating conditions of the other axes.

Appendix 3 Connection Examples with Servo Amplifiers Manufactured by Mitsubishi Electric Corporation

(1) Connection example of QD72P3C3 and MR-J3-□A

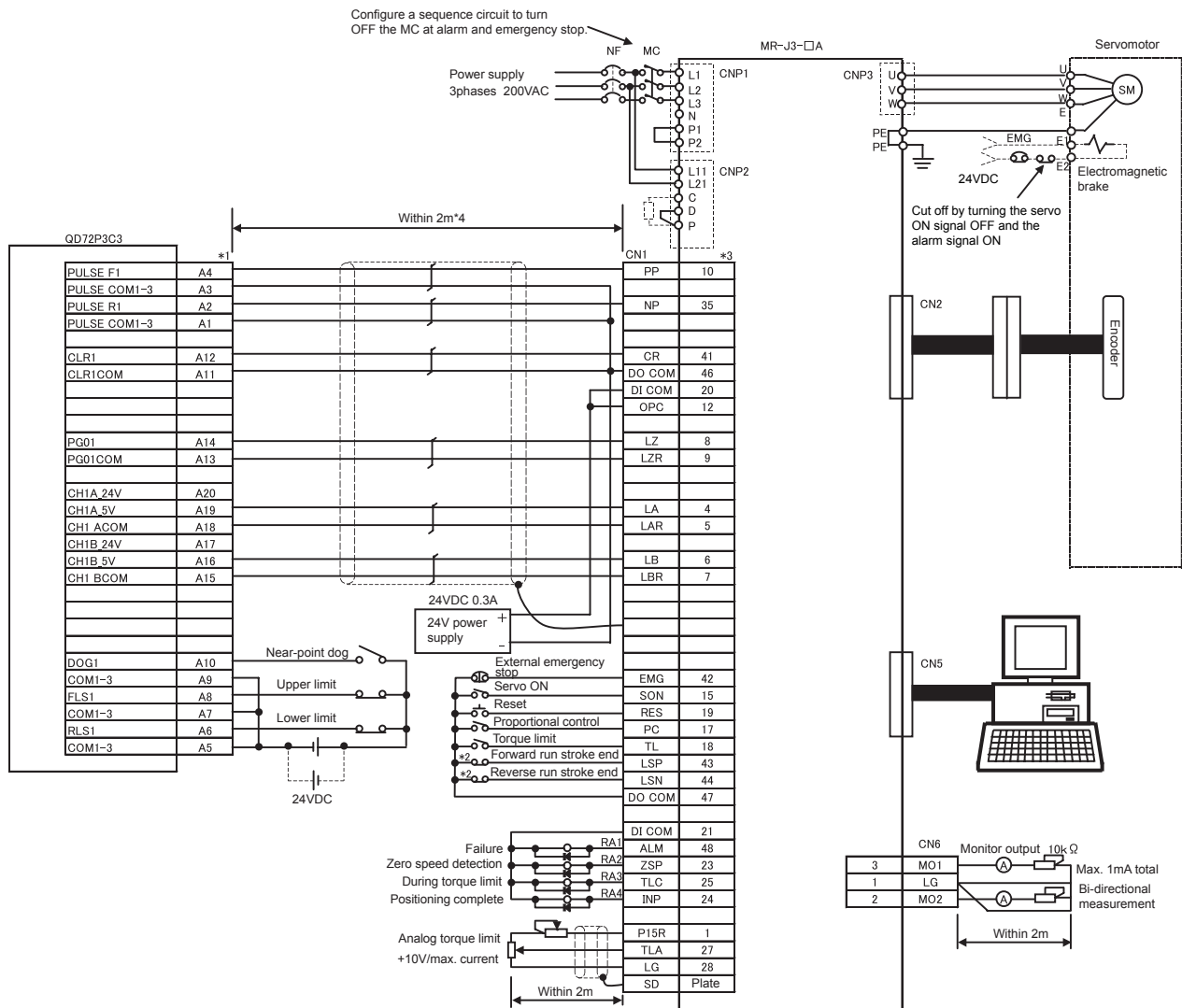

Remark

- *1: The logic of each I/O terminal can be changed by the intelligent function module switch setting (refer to Section 5.6). (The above example assumes that all terminals are set to the negative logic.)
In addition, the above example is for connecting to Axis 1. (For the pin layout when connecting to Axes 2 or 3, refer to "Section 3.5.2 Signal layout for external device connector".)
- *2: These are limit switches for servo amplifier (for stop).
- *3: For details of connection, refer to the MR-J3 series Servo Amplifier Instruction Manual.
- *4: This indicates the distance between the QD72P3C3 and servo amplifier.

(3) Connection example of QD72P3C3 and MR-H□A

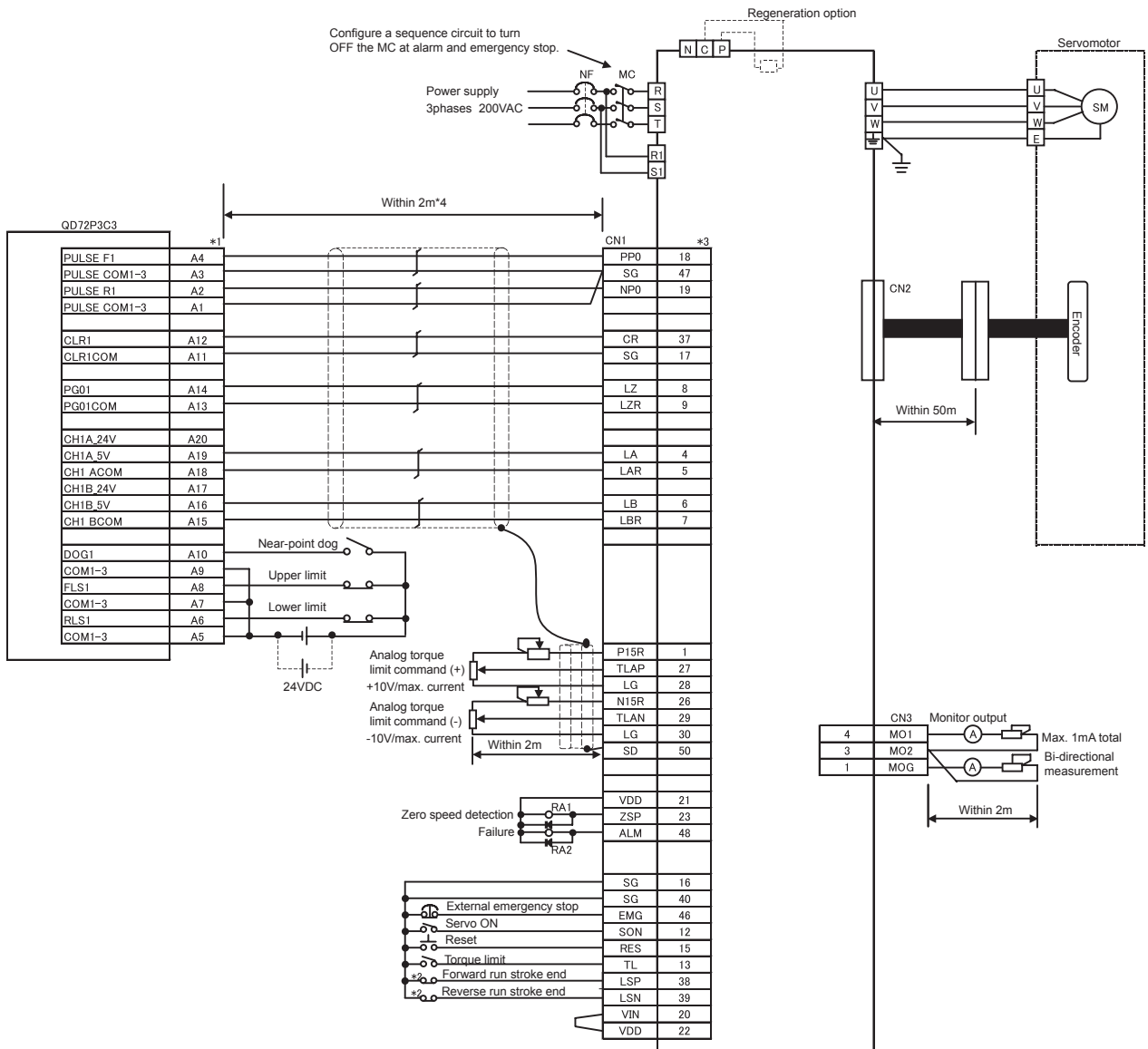

Remark

- *1: The logic of each I/O terminal can be changed by the intelligent function module switch setting (refer to Section 5.6). (The above example assumes that all terminals are set to the negative logic.)
In addition, the above example is for connecting to Axis 1. (For the pin layout when connecting to Axes 2 or 3, refer to "Section 3.5.2 Signal layout for external device connector".)
- *2: These are limit switches for servo amplifier (for stop).
- *3: For details of connection, refer to the MR-H series Servo Amplifier Instruction Manual.
- *4: This indicates the distance between the QD72P3C3 and servo amplifier.

(4) Connection example of QD72P3C3 and MR-C□A

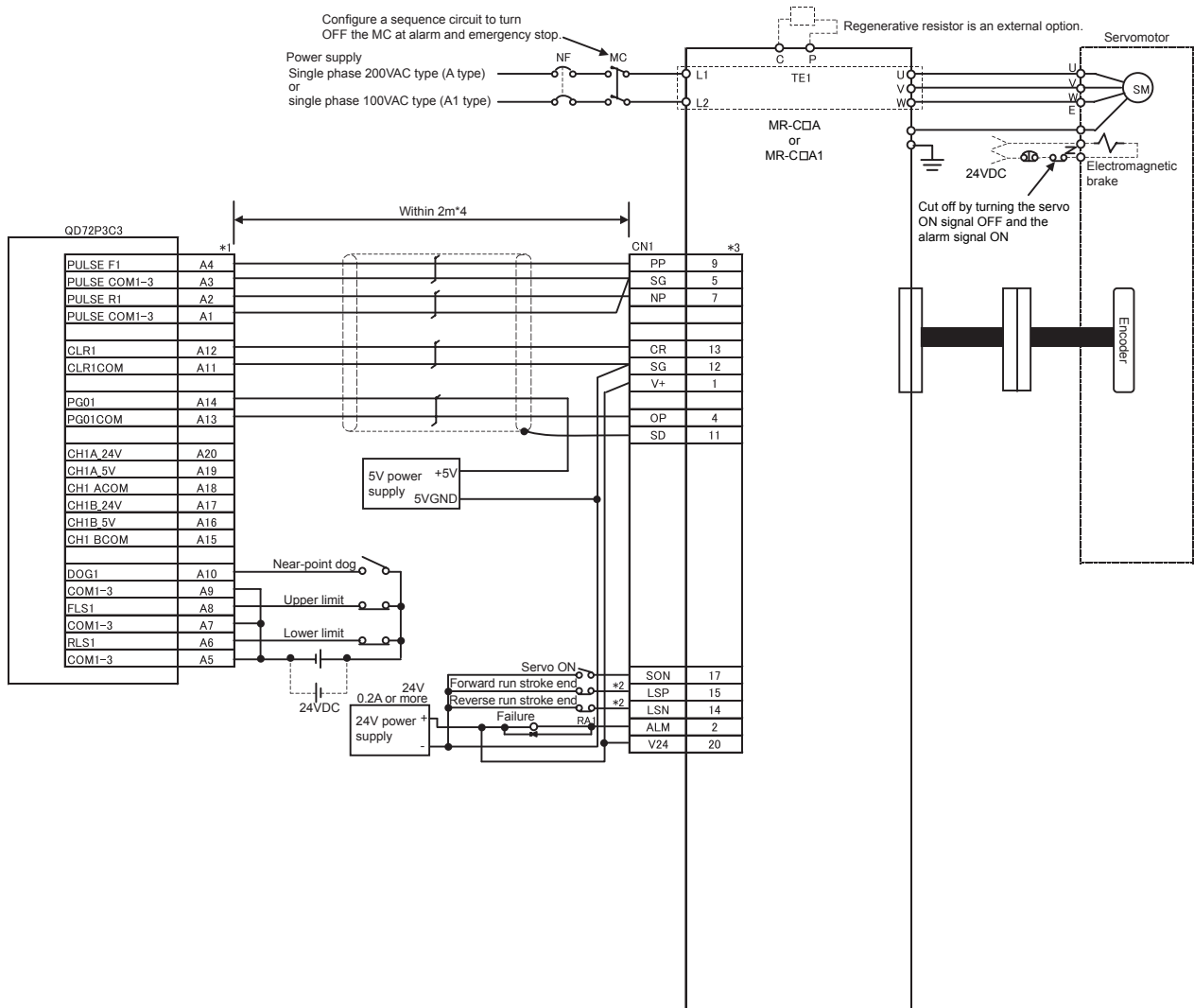

Remark

- *1: The logic of each I/O terminal can be changed by the intelligent function module switch setting (refer to Section 5.6). (The above example assumes that all terminals are set to the negative logic.)
In addition, the above example is for connecting to Axis 1. (For the pin layout when connecting to Axes 2 or 3, refer to "Section 3.5.2 Signal layout for external device connector".)
- *2: These are limit switches for servo amplifier (for stop).
- *3: For details of connection, refer to the MR-C series Servo Amplifier Instruction Manual.
- *4: This indicates the distance between the QD72P3C3 and servo amplifier.

Appendix 4 Connection Examples with Stepping Motors Manufactured by ORIENTAL MOTOR CO., LTD.

(1) Connection example of QD72P2C3 and RK series

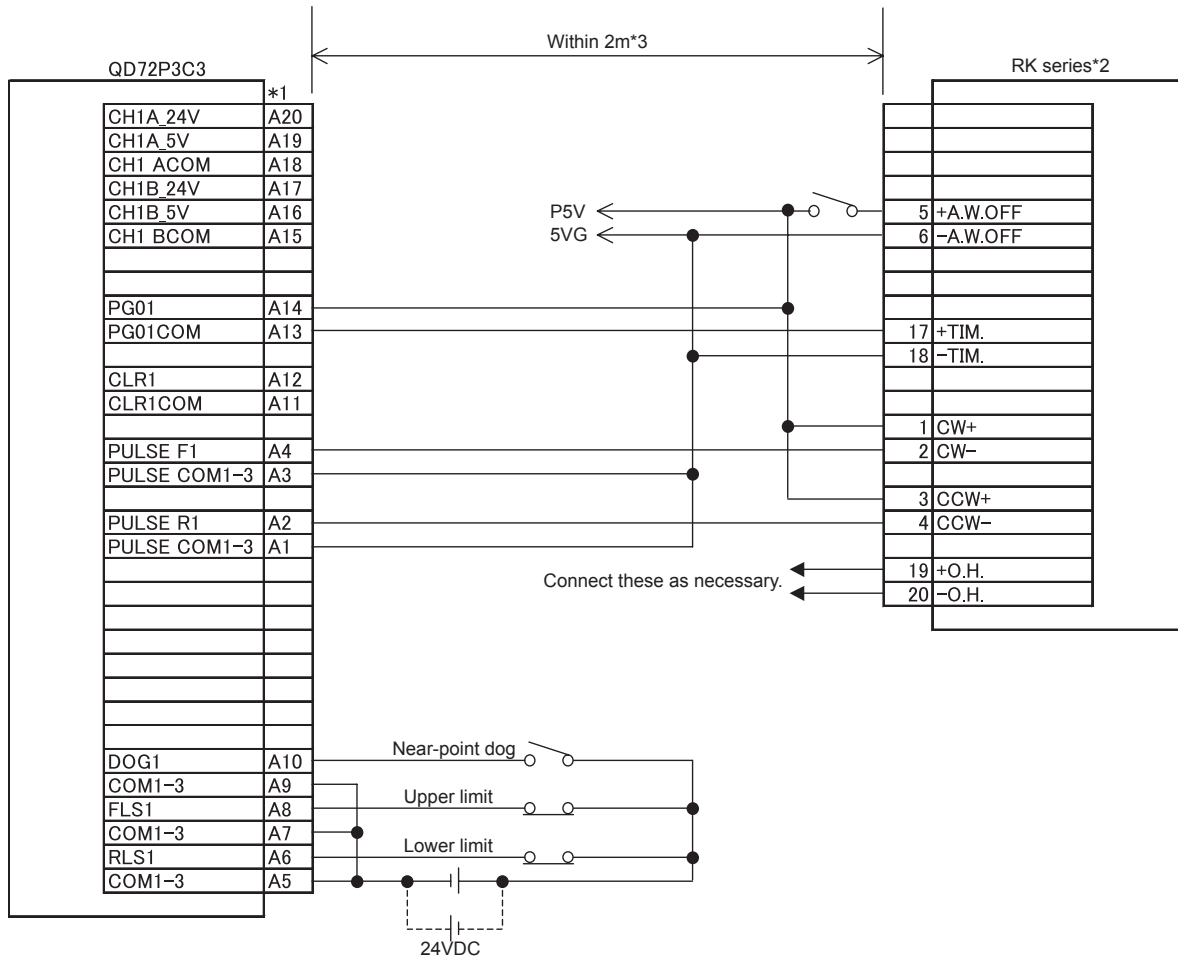

Remark

- *1: The logic of each I/O terminal can be changed by the intelligent function module switch setting (refer to Section 5.6). (The above example assumes that all terminals are set to the negative logic.)
In addition, the above example is for connecting to Axis 1. (For the pin layout when connecting to Axes 2 or 3, refer to "Section 3.5.2 Signal layout for external device connector".)
- *2: For wiring or shield of each signal line of the stepping motor drive side other than mentioned above, refer to the manual for stepping motor drive.
- *3: This indicates the distance between the QD72P3C3 and RK series.

(2) Connection example of QD72P3C3 and α STEP series

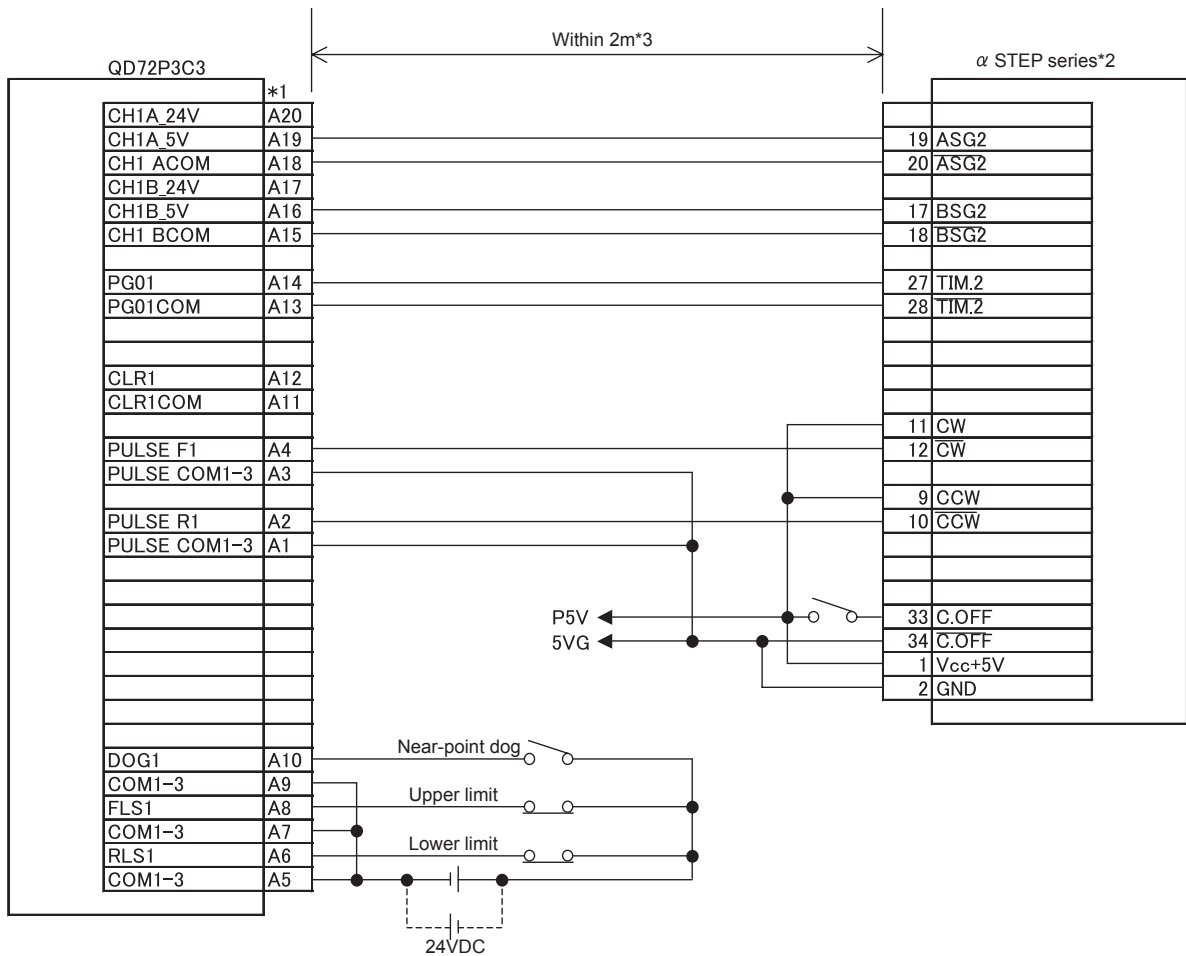

Remark

- *1: The logic of each I/O terminal can be changed by the intelligent function module switch setting (refer to Section 5.6). (The above example assumes that all terminals are set to the negative logic.)
In addition, the above example is for connecting to Axis 1. (For the pin layout when connecting to Axes 2 or 3, refer to "Section 3.5.2 Signal layout for external device connector".)
- *2: For wiring or shield of each signal line of the stepping motor drive side other than mentioned above, refer to the manual for stepping motor drive.
- *3: This indicates the distance between the QD72P3C3 and α STEP series.

(2) Connection example of QD72P2C3 and MINAS-E series

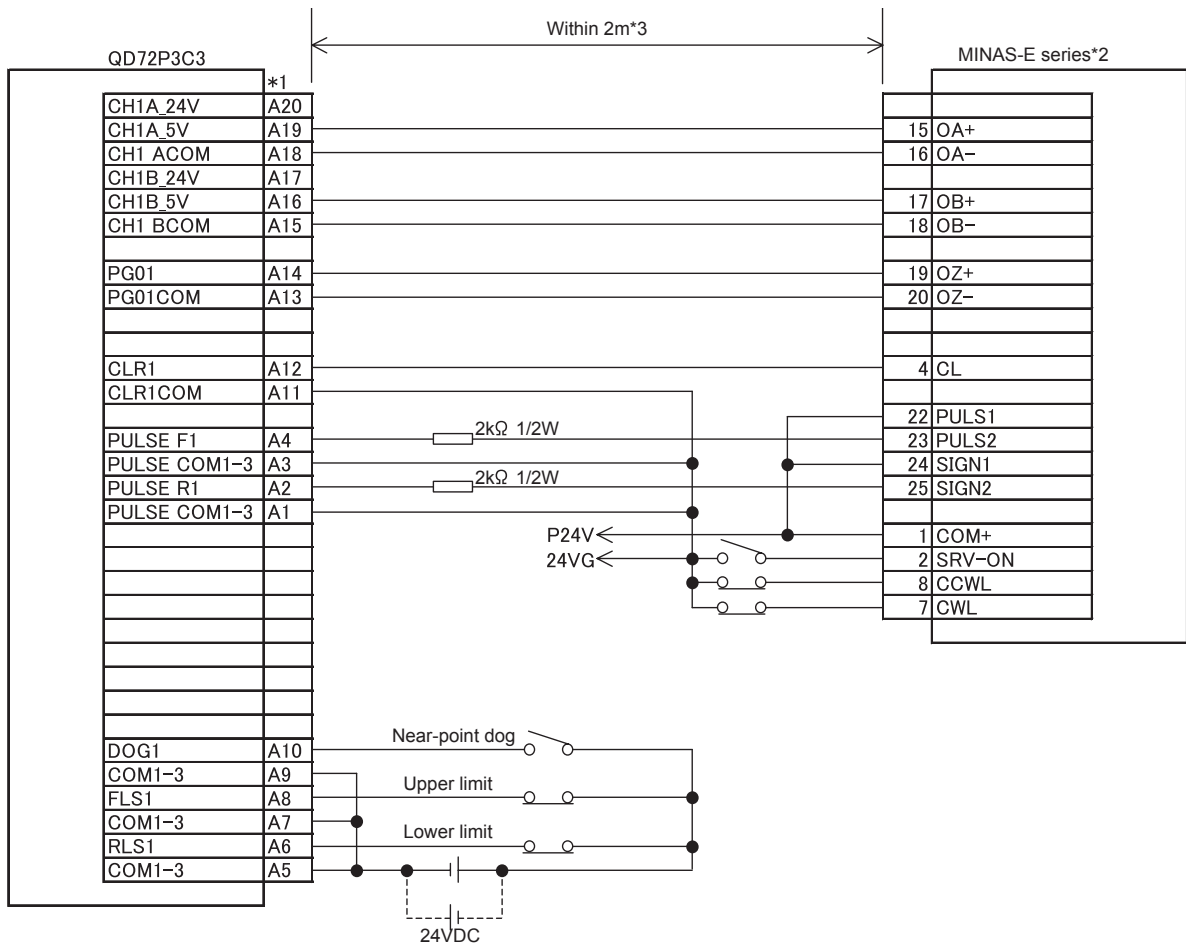

Remark

- *1: The logic of each I/O terminal can be changed by the intelligent function module switch setting (refer to Section 5.6). (The above example assumes that all terminals are set to the negative logic.)
In addition, the above example is for connecting to Axis 1. (For the pin layout when connecting to Axes 2 or 3, refer to "Section 3.5.2 Signal layout for external device connector".)
- *2: For wiring or shield of each signal line of the servo amplifier side other than mentioned above, refer to the manual for servo amplifier.
- *3: This indicates the distance between the QD72P3C3 and MINAS-E series.

Appendix 7 Connection Examples with Servo Amplifiers Manufactured by SANYO DENKI CO., LTD.

(1) Connection example of QD72P2C3 and R series

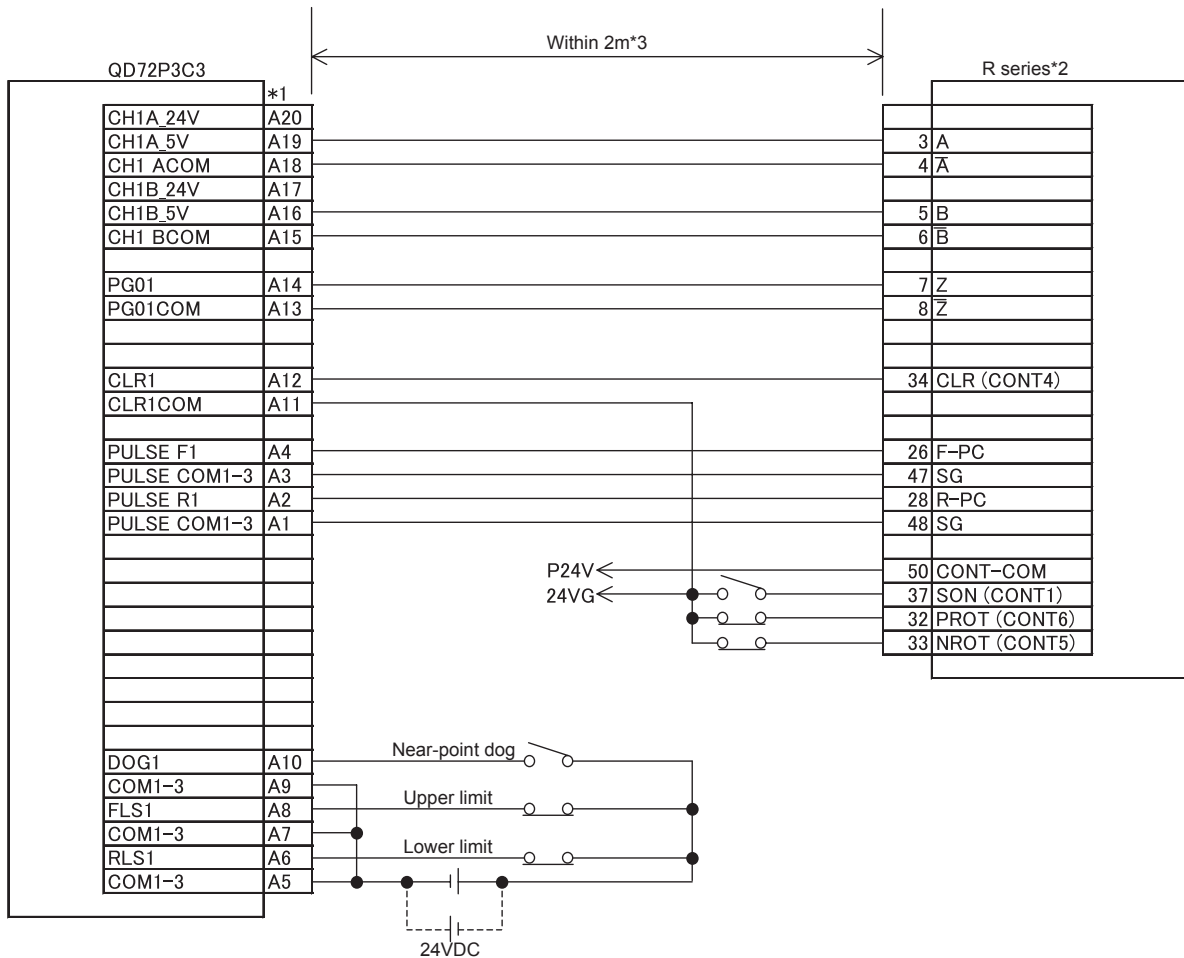

Remark

- *1: The logic of each I/O terminal can be changed by the intelligent function module switch setting (refer to Section 5.6). (The above example assumes that all terminals are set to the negative logic.)
In addition, the above example is for connecting to Axis 1. (For the pin layout when connecting to Axes 2 or 3, refer to "Section 3.5.2 Signal layout for external device connector".)
- *2: For wiring or shield of each signal line of the servo amplifier side other than mentioned above, refer to the manual for servo amplifier.
- *3: This indicates the distance between the QD72P3C3 and R series.

Appendix 8 Comparison with QD70P type positioning module

Item		Model	QD72P3C3	QD70P4	
Number of axes			3 axes	4 axes	
Control unit			pulse	pulse	
Number of positioning data			1/axis ^{*1}	10/axis ^{*1}	
Position control interpolation function	2-axes linear interpolation		×	×	
	3-axes linear interpolation				
	4-axes linear interpolation				
	2-axes circular interpolation				
Positioning control method	Position control	ABS system	○	○	
		INC system	○	○	
		Fixed-feed	×	×	
	Speed control	1 axis	○	×	
		2-axes linear interpolation			
		3-axes linear interpolation	×		
		4-axes linear interpolation			
	Speed-position switching control			×	○
	Position-speed switching control			×	×
	Current value change			○	○
Positioning control range		(ABS system positioning start (independent)) -1073741824 to 1073741823 pulse (ABS system positioning start (continuous)) -1073741824 to 1073741823 pulse (INC system positioning start (independent)) -1073741824 to 1073741823 pulse (INC system positioning start (continuous)) -1073741824 to 1073741823 pulse	(ABS system) -2147483648 to 2147483647 pulse (INC system) -2147483648 to 2147483647 pulse (Speed-position switching control) 0 to 2147483647pulse (INC system)		
Speed command range			1 to 100000pulse/s ^{*3}	1 to 200000pulse/s	
High-level positioning control			No	No	
Machine OPR control			○ (2 types)	○ (6 types)	
JOG operation			○	○	

○: Possible ×: Not possible

Item		Model	QD72P3C3	QD70P4
Inching operation			×	×
Manual pulse generator function			No	No
ACC/DEC processing	Automatic trapezoidal ACC/DEC		○	○
	S-pattern ACC/DEC		×	×
ACC/DEC time			ACC/DEC time can be set. (1 to 5000ms)	ACC/DEC time and DEC/STOP time can be set. (0 to 32767ms)
Auxiliary function	OPR auxiliary function		No	No
	Compensation function		No	No
	Control limit function		Speed limit, software stroke limit, hardware stroke limit	Speed limit, software stroke limit
	Control details change function		Speed change	Speed change
	Absolute position restoration function		×	×
	Other auxiliary functions		No	Restart
Start command			Device Y of the programmable controller CPU	Device Y of the programmable controller CPU
Stop command			Device Y of the programmable controller CPU	Device Y of the programmable controller CPU
Stop method	Deceleration stop		○	○
	Sudden stop		×	×
	Immediate stop		×	○
Current value monitor data			Current feed value	Current feed value
Error display			Error LED	Error LED
History data storage (Start, error, warning)			No	No
Data storage destination			No (Backup invalid)	No (Backup invalid)
Peripheral/software			GX Configurator-PT ^{*2}	GX Configurator-PT ^{*4}
Connector			A6CON1 (soldering type)	A6CON1 (soldering type)
			A6CON2 (crimp type)	A6CON2 (crimp type)
			A6CON1 (soldering type, usable for both straight out and diagonal out)	A6CON1 (soldering type, usable for both straight out and diagonal out)
Applicable wire size			A6CON1, A6CON4 : 0.3mm ²	A6CON1, A6CON4 : 0.3mm ²
			A6CON2: AWG24	A6CON2: AWG24
Output type of command pulse			Open collector	Open collector
Maximum output pulse			100kpps	200kpps
Counter function			○	×
Maximum connection distance to servo			2m	2m
Internal current consumption (5VDC)			0.57A	0.55A
Number of occupied I/O points			32points	32points
Number of slots occupied by module			1	1
Weight			0.16kg	0.17kg

- * 1 Start method of positioning data differs according to the model.
QD70P4: Positioning data can be started from No.1 only. (It cannot be started from No.2 to No.10.)
- * 2 Added into GX Developer for use.
- * 3 Pulse unit for inside of the module differs according to the setting range of the speed limit value.
(For details, refer to "CHAPTER 4.)
Speed limit value 1 to 8000pulse/s: 1-pulse unit
Speed limit value 8001 to 32000pulse/s: 4-pulse unit
Speed limit value 32001 to 64000pulse/s: 8-pulse unit
Speed limit value 64001 to 100000pulse/s: 25-pulse unit

Appendix 9 List of Buffer Memory Addresses

Item	Buffer memory address		
	Axis 1	Axis 2	Axis 3
Pr.1 Software stroke limit upper limit value	0	100	200
	1	101	201
Pr.2 Software stroke limit lower limit value	2	102	202
	3	103	203
Pr.3 Current feed value during speed control	5	105	205
Pr.4 Speed limit value	6	106	206
	7	107	207
Pr.5 Bias speed at start	8	108	208
	9	109	209
Pr.6 Positioning complete signal output time	10	110	210
Pr.7 Deviation counter clear signal output time	11	111	211
Pr.9 Current feed value, count value simultaneous change function selection	13	113	213
Pr.10 OPR method	20	120	220
Pr.11 OPR direction	21	121	221
Pr.12 OP address	22	122	222
	23	123	223
Pr.13 OPR speed	24	124	224
	25	125	225
Pr.14 Creep speed	26	126	226
	27	127	227
Pr.15 ACC/DEC time at OPR	28	128	228
Pr.16 Ring counter upper limit value	30	130	230
	31	131	231
Pr.17 Positioning range upper limit value	32	132	232
	33	133	233
Pr.18 Coincidence detection setting	34	134	234
Pr.19 Count value selection at OPR	35	135	235
JOG.1 JOG speed	40	140	240
	41	141	241
JOG.2 JOG ACC/DEC time	42	142	242

Item	Buffer memory address		
	Axis 1	Axis 2	Axis 3
Da.1 Operation pattern	90	190	290
Da.2 Control method	91	191	291
Da.3 ACC/DEC time	92	192	292
Da.4 Command speed	94	194	294
	95	195	295
Da.5 Positioning address/movement amount	96	196	296
	97	197	297
Md.1 Current feed value	70	170	270
	71	171	271
Md.2 Current speed	72	172	272
	73	173	273
Md.3 Count value	74	174	274
	75	175	275
Md.4 Axis operation status	76	176	276
Md.5 Axis/CH error code	77	177	277
Md.7 Axis/CH warning code	78	178	278
Md.7 Status	79	179	279
Md.8 External I/O signal	80	180	280
Cd.1 New speed value	50	150	250
	51	151	251
Cd.2 ACC/DEC time at speed change	52	152	252
Cd.3 Speed change request	54	154	254
Cd.4 OPR request flag OFF request	55	155	255
Cd.5 Start method	56	156	256
Cd.6 Preset value setting	60	160	260
	61	161	261
Cd.7 Coincidence detection point setting	62	162	262
	63	163	263

* The writing of the addresses not indicated on the list are disabled. If the unlisted address is used, the system may not operate normally.

INDEX

[A]

- Absolute system 9-4
- ACC/DEC process function 3-2

[C]

- Coincidence detection function 3-3
- Connection check 5-12
- Control data 4-6
- Count enable function 3-3
- Count value selection function at OPR 3-2
- Counting range 3-1
- Counting speed 3-1
- Current feed value, count value simultaneous change function 3-3
- Current value change 3-2
- CW/CCW 5-15,5-16

[D]

- Da.1 Operation pattern 4-5
- Da.2 Control method 4-5
- Da.3 ACC/DEC time 4-5
- Da.4 Command speed 4-5
- Da.5 Positioning address/movement amount 4-5

[E]

- Electrical specifications 3-12
- Error code list 15-7
- External I/O signal logic switching function 3-3
- External I/O signal monitor function 3-3

[F]

- Fast OPR control 3-2

[G]

- GX Configurator-PT 6-1

[H]

- Hardware stroke limit function 3-2

[I]

- Incremental system 9-4
- Intelligent Function Module Switch Setting 5-14
- Internal current consumption 3-1
- I/O interface 3-18

[J]

- JOG data 4-5
- JOG operation 3-2,10-1
 - JOG operation start timing chart 10-2
- JOG.1 JOG speed 4-5
- JOG.2 JOG ACC/DEC time 4-5

[L]

- LED display 5-5,15-21
- Linear counter function 3-3
- List of warnings 15-19

[M]

- Machine OPR control 3-2
- Maximum connection distance 3-1
- Maximum output pulse 3-1
- Monitor data 4-6
- Movement amount per pulse 1-4
- Multiple axes concurrent start control 9-15

[N]

- Number of axes 3-1
- Number of channels 3-1
- Number of occupied I/O points 3-1

[O]

- OPR control 3-2,8-1
 - Count value selection function at OPR 8-12
 - Fast OPR control 8-10
 - Fast OPR control start timing chart 7-28
 - Machine OPR control start timing chart 7-27
 - Near-point dog method 8-5
 - Processing time of fast OPR control App-3
 - Processing time of machine OPR control App-2

[P]

- Parameter 4-3
- Part Names 5-4
- Performance Specifications 3-1
- Position control 3-2
- Positioning control 3-2
 - Positioning control start timing chart 7-28
 - Processing time of positioning control App-4
- Positioning control range 3-1
- Positioning data 4-5
- Preset function 3-3
- Pr.1 Software stroke limit upper limit value 4-3
- Pr.10 OPR method 4-3
- Pr.11 OPR direction 4-3
- Pr.12 OP address 4-3
- Pr.13 OPR speed 4-3
- Pr.14 Creep speed 4-3
- Pr.15 ACC/DEC time at OPR 4-3
- Pr.16 Ring counter upper limit value 4-3
- Pr.17 Positioning range upper limit value 4-3
- Pr.18 Coincidence detection setting 4-3
- Pr.19 Count value selection at OPR 4-3
- Pr.2 Software stroke limit lower limit value 4-3
- Pr.3 Current feed value during speed control 4-3
- Pr.4 Speed limit value 4-3
- Pr.5 Bias speed at start 4-3

Pr.6 Positioning complete signal output time.....	4-3
Pr.7 Deviation counter clear signal output time....	4-3
Pr.9 Current feed value, count value simultaneous change function selection	4-3
PULSE/SIGN	5-15

[Q]

QD70P	App-17
-------------	--------

[R]

Ring counter function	3-3
-----------------------------	-----

[S]

Signal	3-4
Axis stop signal	3-4,3-8
Axis/CH error occurrence signal	3-4,3-6
Axis/CH error reset signal	3-4,3-8
Axis/CH warning occurrence signal	3-4,3-6
BUSY signal	3-4,3-6
Coincidence signal reset command	3-4,3-9
Count enable command	3-4,3-9
Count value coincidence	3-4,3-7
Count value large	3-4,3-7
Count value small.....	3-4,3-7
Forward run JOG start signal.....	3-4,3-8
Module READY signal	3-4,3-6
Positioning complete signal.....	3-4,3-6
Positioning start signal.....	3-4,3-8
Preset command.....	3-4,3-9
Programmable controller CPU READY signal	3-4,3-8
Reverse run JOG start signal	3-4,3-8
Start complete signal.....	3-4,3-6
Signal layout for connector	3-16
Simple Reciprocating Operation	5-18
Software stroke limit function.....	3-2
Speed change function	3-2
Speed change timing chart	7-30
Speed command.....	3-1
Speed control.....	3-2
Speed limit function	3-2
Start time	3-1
Stopper 3.....	8-8

[T]

TROUBLESHOOTING	15-1
When the Axis/CH warning occurrence turns ON	15-2
When the coincidence detection interrupt does not occur	15-4
When the count operation is not executed, or not executed normally	15-3
When the RUN LED turns OFF	15-2
When the AX LED flashes after the ERR.LED flashes	15-2
When the ERR.LED turns OFF	15-2

[U]

UTILITY PACKAGE	6-1
-----------------------	-----

[W]

Weight	3-1
--------------	-----

Numerics

1 multiple of 2 phases	5-16
1-axis linear control (ABS)	9-8
1-axis linear control (INC)	9-9
2 multiples of 2 phases	5-16
4 multiples of 2 phases	5-16

Warranty

Please confirm the following product warranty details before using this product.

1. Gratis Warranty Term and Gratis Warranty Range

If any faults or defects (hereinafter "Failure") found to be the responsibility of Mitsubishi occurs during use of the product within the gratis warranty term, the product shall be repaired at no cost via the sales representative or Mitsubishi Service Company.

However, if repairs are required onsite at domestic or overseas location, expenses to send an engineer will be solely at the customer's discretion. Mitsubishi shall not be held responsible for any re-commissioning, maintenance, or testing on-site that involves replacement of the failed module.

[Gratis Warranty Term]

The gratis warranty term of the product shall be for one year after the date of purchase or delivery to a designated place.

Note that after manufacture and shipment from Mitsubishi, the maximum distribution period shall be six (6) months, and the longest gratis warranty term after manufacturing shall be eighteen (18) months. The gratis warranty term of repair parts shall not exceed the gratis warranty term before repairs.

[Gratis Warranty Range]

- (1) The range shall be limited to normal use within the usage state, usage methods and usage environment, etc., which follow the conditions and precautions, etc., given in the instruction manual, user's manual and caution labels on the product.
- (2) Even within the gratis warranty term, repairs shall be charged for in the following cases.
 1. Failure occurring from inappropriate storage or handling, carelessness or negligence by the user. Failure caused by the user's hardware or software design.
 2. Failure caused by unapproved modifications, etc., to the product by the user.
 3. When the Mitsubishi product is assembled into a user's device, Failure that could have been avoided if functions or structures, judged as necessary in the legal safety measures the user's device is subject to or as necessary by industry standards, had been provided.
 4. Failure that could have been avoided if consumable parts (battery, backlight, fuse, etc.) designated in the instruction manual had been correctly serviced or replaced.
 5. Failure caused by external irresistible forces such as fires or abnormal voltages, and Failure caused by force majeure such as earthquakes, lightning, wind and water damage.
 6. Failure caused by reasons unpredictable by scientific technology standards at time of shipment from Mitsubishi.
 7. Any other failure found not to be the responsibility of Mitsubishi or that admitted not to be so by the user.

2. Onerous repair term after discontinuation of production

(1) Mitsubishi shall accept onerous product repairs for seven (7) years after production of the product is discontinued.

Discontinuation of production shall be notified with Mitsubishi Technical Bulletins, etc.

(2) Product supply (including repair parts) is not available after production is discontinued.

3. Overseas service

Overseas, repairs shall be accepted by Mitsubishi's local overseas FA Center. Note that the repair conditions at each FA Center may differ.

4. Exclusion of loss in opportunity and secondary loss from warranty liability

Regardless of the gratis warranty term, Mitsubishi shall not be liable for compensation of damages caused by any cause found not to be the responsibility of Mitsubishi, loss in opportunity, lost profits incurred to the user by Failures of Mitsubishi products, special damages and secondary damages whether foreseeable or not, compensation for accidents, and compensation for damages to products other than Mitsubishi products, replacement by the user, maintenance of on-site equipment, start-up test run and other tasks.

5. Changes in product specifications

The specifications given in the catalogs, manuals or technical documents are subject to change without prior notice.

Microsoft, Windows, Windows NT, and Windows Vista are registered trademarks of Microsoft Corporation in the United States and other countries.

Pentium is a trademark of Intel Corporation in the United States and other countries.

Ethernet is a registered trademark of Xerox Corporation in the United States.

Other company names and product names used in this document are trademarks or registered trademarks of respective companies.

SPREAD

Copyright (C) 1996 Farpoint Technologies, Inc.

QD72P3C3 Type Positioning Module with Built-in Counter Function

User's Manual

MODEL	QD72P3C3-U-SY-E
MODEL CODE	13JR99
SH(NA)-080683ENG-E(1005)MEE	



HEAD OFFICE : TOKYO BUILDING, 2-7-3 MARUNOUCHI, CHIYODA-KU, TOKYO 100-8310, JAPAN
NAGOYA WORKS : 1-14, YADA-MINAMI 5-CHOME, HIGASHI-KU, NAGOYA, JAPAN

When exported from Japan, this manual does not require application to the Ministry of Economy, Trade and Industry for service transaction permission.

Specifications subject to change without notice.